



BEACH COMMUNITY DEVELOPMENT DISTRICT

Advanced Meeting Package

Regular Meeting

*Monday
April 20, 2026
6:00 p.m.*

*Location:
12788 Meritage Blvd.,
Jacksonville, FL 32246*

*Note: The Advanced Meeting Package is a working document and thus all materials are considered **DRAFTS** prior to presentation and Board acceptance, approval, or adoption.*

Beach

Community Development District

250 International Parkway, Suite 208
Lake Mary, FL 32746
321-263-0132

Board of Supervisors
Beach Community Development District

Dear Board Members:

The Regular Meeting of the Board of Supervisors of the Beach Community Development District is scheduled for **Monday, April 20, 2026, at 6:00 p.m.** at the **12788 Meritage Blvd., Jacksonville, FL 32246**

An advanced copy of the agenda for the meeting is attached along with associated documentation for your review and consideration. Any additional support material will be distributed at the meeting.

Should you have any questions regarding the agenda, please contact me at (321) 263-0132 X-193 or dmcinnes@vestapropertyservices.com . We look forward to seeing you at the meeting.

Sincerely,

David McInnes

David McInnes
District Manager

Cc: Attorney
Engineer
District Records

Beach Community Development District

Meeting Date: Monday, April 20, 2026 Call-in Number: +1 (929) 205-6099
Time: 6:00 PM Meeting ID: 705 571 4830#
Location: 12788 Meritage Blvd., (Listen Only)
Jacksonville, FL 32246

Revised Agenda

- I. Roll Call**
- II. Pledge of Allegiance**
- III. Audience Comments** – *(limited to 3 minutes per individual for agenda items)*
- IV. Presentation of Proof of Publication(s)** [Exhibit 1](#)
[Pg. 7](#)
- V. Vendor Reports – Questions from Board Members Only**
 - A. **The Greenery, Inc.** [Exhibit 2](#)
[Pgs. 9-123](#)
 - B. Vesta Property Services
 - 1. Lifestyle Management Report [Exhibit 3](#)
[Pgs. 25-28](#)
 - 2. Field Management Report [Exhibit 4](#)
[Pg. 30](#)
- VI. Staff Reports – Questions from Board Members Only**
 - A. District Counsel
 - B. District Engineer
 - C. District Manager
 - 1. Resident(s) Subject to Disciplinary Action
 - 2. Complaint & Incident Management Tracker
 - 3. Action Item Report [Exhibit 5](#)
[Pgs. 32-36](#)
 - 4. Meeting Matrix [Exhibit 6](#)
[Pgs. 38-44](#)
- VII. Consent Agenda**
 - A. Consideration for Approval – The Minutes of the Board of Supervisors Regular Meeting Held on March 16, 2026 [Exhibit 7](#)
[Pgs. 46-50](#)
 - B. Consideration for Approval – The Minutes of the Board of Supervisors Workshop Held on April 2, 2026 [Exhibit 8](#)
[Pgs. 52-54](#)
 - C. Consideration for Acceptance – The March 2026 Unaudited Financial Statements [Exhibit 9](#)
[Pgs. 56-112](#)

VII. Consent Agenda - continued

- D. Ratification of IAS invoice for Gate Repair - \$1,280.00 [Exhibit 10](#)
[Pg. 114](#)
- E. Ratification of Morgan Inland LLC Equipment Proposal NTE \$20,000 & GTI Guys Installation Proposal NTE \$5,000 (Contingency; CRF; Line 9) [Exhibit 11](#)
[Pgs. 116-121](#)
- F. Ratification of C Buss Enterprises, Inc. Proposal for Emergency Pool Repair - \$3,457.59 [Exhibit 12](#)
[Pg. 123](#)
- G. Approval of the Southern Breeze Pool Area Chairs and Tables (Option 3) from the 4/2/2026 Workshop - \$ 53,541.32 plus 2 Additional Tables and 8 Chairs – Revised Total of \$59,142.00 (CIP-Future FY; CRF; Line 8) [Exhibit 13](#)
[Pg. 125](#)
- H. Approval of the 360 Painting Paver Repair Proposal from the 4/2/2026 Workshop - \$6,286.00 (Community and Amenity Repairs; GF; Line 38) [Exhibit 14](#)
[Pg. 127](#)
- I. Approval of the Ice Machine Proposal from KaTom Restaurant Supply Inc. from the 4/2/2026 Workshop – NTE \$12,000 with Installation fir a Smaller Unit of (250 lbs. to 350 lbs. (Contingency; CRF; Line 9) [Exhibit 15](#)
[Pgs. 129-134](#)
- J. Approval of Revised Post Orders from the 4/2/2026 Workshop—
Under Separate Cover
- K. Approval to Amend Beach CDD Comprehensive Amenity Facility Policies (dated 11/17/2025) and Facility Rental Application (if applicable) to: [Exhibit 16](#)
[Pgs. 136-186](#)
1. Change Water Slide Operational Hours (Monday: Closed; Tuesday-Friday: Noon-7:00 PM; Saturday, Sunday and Holidays: 10:00 AM-7:00 PM)--from the 4/2/2026 Workshop
 2. No Longer Require Additional Staff for Events with Over 25 Individuals Attending--from the 4/2/2026 Workshop
 3. Require Individuals to be 21 Years of Age to Attend Adult Events--from the 4/2/2026 Workshop
- L. Approval of Revised Tamaya Facility Rental Agreement from the 4/2/2026 Workshop to No Longer Require Additional Staff for Events with Over 25 Individuals Attending [Exhibit 17](#)
[Pgs. 188-200](#)

VIII. Business Items

- A. Replacement of Breezeway Staff with Highline Security (Check-In No Longer Require)
 - 1. Highline Security Proposal
 - 2. Consideration of Roving Patrol Post Orders—*Under Separate Cover*
- B. Consideration of Purchase of Pool Furniture from Southern Breeze (CIP-Future FY; CRF; Line 8)—Supervisor Young
 - 1. Option 1: Chaise Lounge--\$25,282.00
 - 2. Option 2: Chaise Lounge-\$30,127.00
 - 3. Option 3: Chaise Lounge-\$37,252.00
- C. **Consideration & Adoption of Resolution 2026-05, Relating to the Disposal of Surplus Furniture**
- D. **Consideration & Adoption of Resolution 2026-06, Setting Public Hearing on Revised Rules of Procedure**

[Exhibit 18](#)

[Pgs. 202-205](#)

[Exhibit 19](#)

[Pgs. 207-214](#)

[Exhibit 20](#)

[Pgs. 216-223](#)

[Exhibit 21](#)

[Pgs. 225-232](#)

[Exhibit 22](#)

[Pgs. 234-235](#)

[Exhibit 23](#)

[Pg. 237](#)

IX. Discussion Topics

X. Supervisors' Requests

XI. Audience Comments (*limited to 3 minutes per individual for non-agenda items*)

XII. Action Items Summary

XIII. Meeting Matrix Summary

XIV. Next Workshop Confirmation or Cancellation: May 7 at 6:00PM

XV. Next Meeting Quorum Check: May 18th at 6:00PM

Todd Caprita	<input type="checkbox"/> IN PERSON	<input type="checkbox"/> REMOTE	<input type="checkbox"/> NO
Walter Repak	<input type="checkbox"/> IN PERSON	<input type="checkbox"/> REMOTE	<input type="checkbox"/> NO
Karen Young	<input type="checkbox"/> IN PERSON	<input type="checkbox"/> REMOTE	<input type="checkbox"/> NO
Pawel Szeszko	<input type="checkbox"/> IN PERSON	<input type="checkbox"/> REMOTE	<input type="checkbox"/> NO
James Kendig	<input type="checkbox"/> IN PERSON	<input type="checkbox"/> REMOTE	<input type="checkbox"/> NO

XVI. Adjournment

EXHIBIT 1

**BEACH COMMUNITY
DEVELOPMENT DISTRICT
NOTICE OF BOARD
OF SUPERVISORS
REGULAR MEETING**

Notice is hereby given that a regular meeting of the Board of Supervisors of the Beach Community Development District (the "**District**") will be held on Monday, April 20, 2026, at 6:00 p.m. at 12788 Meritage Blvd. Jacksonville, FL 32246. The purpose of the meeting is to discuss any topics presented to the board for consideration.

Copies of the agenda may be obtained from the District Manager, Vesta District Services, 250 International Parkway, Suite 208, Lake Mary, Florida 32746, Telephone (321) 263-0132, Ext. 193.

The meeting is open to the public and will be conducted in accordance with the provisions of Florida law for community development districts. The meeting may be continued in progress without additional notice to a date, time, and place to be specified on the record at the meeting. There may be occasions when Staff and/or Supervisors may participate by speaker telephone.

Pursuant to provisions of the Americans with Disabilities Act, any person requiring special accommodations to participate in the meeting is asked to advise the District Manager's office at least forty-eight (48) hours before the meeting by contacting the District Manager at (321) 263-0132, Ext. 193. If you are hearing or speech impaired, please contact the Florida Relay Service at 711, for assistance in contacting the District Manager's office.

A person who decides to appeal any decision made at the meeting, with respect to any matter considered at the meeting, is advised that a record of the proceedings is needed and that accordingly, the person may need to ensure that a verbatim record of the proceedings is made, including the testimony and evidence upon which the appeal is to be based.

Beach Community

Development District

David McInnes, District Manager

(321) 263-0132, Ext. 193

Apr. 9

00 (26-01988D)

EXHIBIT 2



Beach.pdf

Created On:
April 14, 2026

Property Size:
70.77 Acres

Report By:
William Allen Flannery

No. of Notes:
17



[Property Map](#)

A1 CCR - Accomplishments

Created On March 31, 2026 by William Allen Flannery

Tags ● Accomplishment Accomplishment



[Open Note on Map](#)

1. CCR - Accomplishments

1.a. Accomplishment

Our team are working hard cleaning things up! Work on Beach Blvd entrance. Cleaned beds, sprayed beds, pruned jasmine, pruned overgrown ornamentals, put straight edge on bed material (shrubs and juniper) and pruned shrubs on barrier wall

Note Attachments

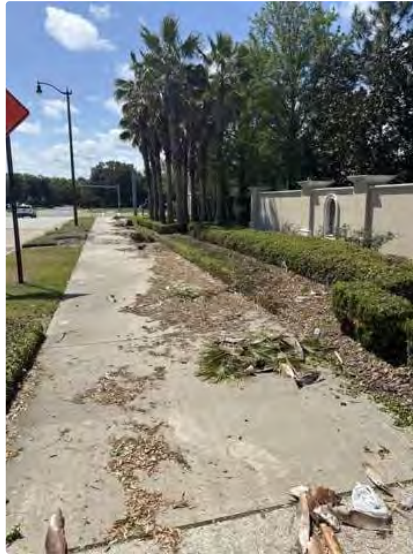

A2 CCR - Accomplishments

Created On March 31, 2026 by William Allen Flannery

 Created On Site

Tags ● Accomplishment Accomplishment



[Open Note on Map](#)

1. CCR - Accomplishments

1.a. Accomplishment

Our team are diligently working through detailing the entrance area. We are removing debris, hand pruning plant material.

Note Attachments



1 Our team has been busy bringing the landscaped up to standard.

Created On April 13, 2026 by William Allen Flannery



[Open Note on Map](#)

Note Attachments



2 Here we are working on trimming our shrubs and ground cover

Created On April 13, 2026 by William Allen Flannery

2

[Open Note on Map](#)

Note Attachments

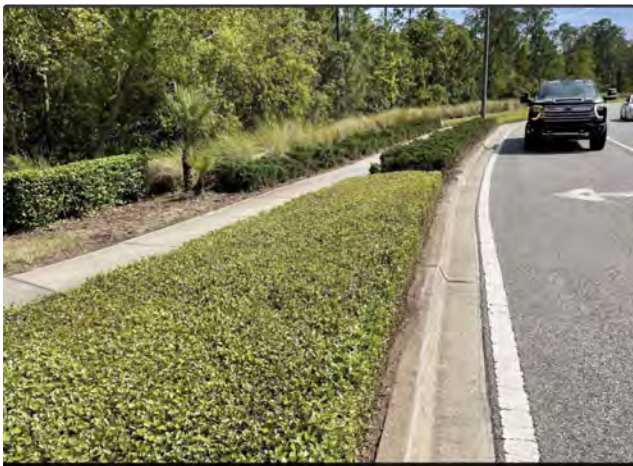

A3 CCR - Accomplishments

Created On April 13, 2026 by William Allen Flannery

Tags ● Accomplishment

A3

[Open Note on Map](#)

1. CCR - Accomplishments

1.a. Accomplishment

Here we see our team accomplished mowing this section this past week. Our PHC team are preparing to follow up with the approved Turf treatment.

Note Attachments



NI CCR - Notes to Owner/Client

Created On April 13, 2026 by William Allen Flannery

Created On Site

Tags Note



[Open Note on Map](#)

1. CCR - Notes to Owner/Client

1.a. Notes to Owner/Client

Our Dutch team has begun spraying out unwanted grass growing through Jasmine in a few few selected areas around the clubhouse. We will continue monitoring and retreat as needed.

Note Attachments





A4 CCR - Accomplishments

Created On April 13, 2026 by William Allen Flannery

Created On Site

Tags ● Accomplishment



[Open Note on Map](#)

1. CCR - Accomplishments

1.a. Accomplishment

Team has been working on redefining the edge line and Jasmine and hard edges as well

Note Attachments





MI CCR - Maintenance Item

Created On April 13, 2026 by William Allen Flannery

 Created On Site

Tags ● Maintenance Item



[Open Note on Map](#)

1. CCR - Maintenance Item

1.a. Maintenance Item

Our production team have been given a new work order to identify, prune and removed dead material out of Juniper beds at the clubhouse area. We call these work orders "ISSUES". So if you hear us talk about issues, this is what we are referring to.

Note Attachments





A5 CCR - Accomplishments

Created On April 13, 2026 by William Allen Flannery

Created On Site

Tags Accomplishment

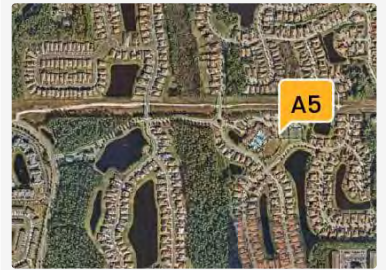

[Open Note on Map](#)

1. CCR - Accomplishments

1.a. Accomplishment

Our production team has worked their way through and pruned Indian Hawthorne to shape and also for function by getting it away from the pathway

Note Attachments



A6 CCR - Accomplishments

Created On April 13, 2026 by William Allen Flannery

Created On Site

Tags Accomplishment



[Open Note on Map](#)

1. CCR - Accomplishments

1.a. Accomplishment

For this section of Hawthorne, there was an abundance of grass that had taken over the shrubs. Our team has worked their way through to clean this up and apply the first herbicide treatment to combat this issue. We will continue to monitor and retreat as needed.

Note Attachments



N2 CCR - Notes to Owner/Client

Created On April 13, 2026 by William Allen Flannery

Created On Site

Tags Note



[Open Note on Map](#)

1. CCR - Notes to Owner/Client

1.a. Notes to Owner/Client

Our team needs guidance from the board regarding this area that appears to once have been a landscaped bed, but has grass that has overtaken. We would like to know if the Board prefers to keep the grass in this area or would like a proposal to remove the grass and re-landscape.

Note Attachments



N3 CCR - Notes to Owner/Client

Created On April 13, 2026 by William Allen Flannery

Created On Site

Tags Note



[Open Note on Map](#)

1. CCR - Notes to Owner/Client

1.a. Notes to Owner/Client

Our production team has more detailing and pruning to do on the backside of the pool area. An ISSUE has been created to bring this to the teams attention

Note Attachments





N4 CCR - Notes to Owner/Client

Created On April 13, 2026 by William Allen Flannery

Created On Site

Tags Note



[Open Note on Map](#)

1. CCR - Notes to Owner/Client

1.a. Notes to Owner/Client

Our production team have been working on trimming and cleaning frost damaged Robolini palms, due to the sensitive nature of these particular palms, some may not bounce back. We will continue to monitor for progress.

Note Attachments



N5 CCR - Notes to Owner/Client

Created On April 13, 2026 by William Allen Flannery

Created On Site

Tags Note



[Open Note on Map](#)

1. CCR - Notes to Owner/Client

1.a. Notes to Owner/Client

Here in front of the clubhouse, we have rosebushes that are either under performing or are completely dead. We would like to ask the board for direction on if they should simply be removed or replaced. If replacement is what the board prefers, we would recommend replacing with a different type of plant.

Note Attachments



A7 CCR - Accomplishments

Created On April 13, 2026 by William Allen Flannery

Tags ● Accomplishment



[Open Note on Map](#)

1. CCR - Accomplishments

1.a. Accomplishment

Our Enhancement team has been working very hard on the approved drainage job. We are very excited about the result and are thankful for the opportunity that the board gave us.

Note Attachments



N6 CCR - Notes to Owner/Client

Created On April 13, 2026 by William Allen Flannery

Tags Note



[Open Note on Map](#)

1. CCR - Notes to Owner/Client

1.a. Notes to Owner/Client

There are a handful of Podocarpus that are failing or are completely dead. We ask direction from Board if you would like us to provide a price to replace the shrubs we are happy to do that for you. There are approximately 13 in total

Note Attachments



CCR - Cover Letter Details

Created On April 13, 2026 by William Allen Flannery

Tags  Client Details



[Open Note on Map](#)

1. CCR - Cover Letter Details

- 1.a. **Customer Name**
Beach CDD at Tamaya

End of Report

EXHIBIT 3



Amenity Managers Report

Date of report: **3.28.2026**

Submitted by: **Oliver Ingram & Kaylie Fitzhugh**

Notables

- Please be advised that The Greenery, Inc. will take over landscaping services from Rupert for the Tamaya / Beach CDD starting April 1, 2026. We appreciate Rupert's service to the community and look forward to working with The Greenery, Inc. moving forward
- We have currently hired 11 of the 12 lifeguards needed, and we are on track to complete staffing in time for the summer season and the water slide opening for Memorial Day weekend.
- This is a reminder that the Tamaya Easter Event will take place on Saturday, March 28th, from 3:00–6:00 PM. Please be sure to arrive on time, as the Easter Egg Hunt will begin promptly at the scheduled start time. Unfortunately, we will not be able to accommodate late arrivals, and we will not be responsible if your child misses the hunt. We look forward to celebrating with you!
- We have identified unauthorized use of the amenity dumpsters by residents, which has resulted in the dumpsters being filled before the scheduled pickup. The amenity dumpster is for **amenity staff use only**. Residents are **not permitted** to use these dumpsters unless they have rented an amenity space for an approved event and are disposing of trash after completing the required cleanup. Any unauthorized use may result in enforcement action.
- We continue to have incidents of vehicles hitting the gate arm in the resident lane and leaving without reporting it. If you witness this happening, please contact Security or the Amenity Office immediately. If possible, please provide a photo of the vehicle and its license plate, as this will help us identify the party responsible and recover repair costs. Thank you for your assistance in keeping our community safe and well-maintained
- We have submitted a proposal for a commercial ice machine to the Board Chair, and it will be included on the agenda for the Board Workshop scheduled for Thursday, April 2, for further discussion.
- The estimated cost to repair the freezer in the kitchen's older refrigerator—which was installed to replace the built-in Sub-Zero unit—is between **\$14,000 and \$16,000** (refer to email dated **March 10, 2026, at 3:03 PM**). Due to the high repair cost, it is recommended that the unit be replaced with a **non-commercial refrigerator**, with an estimated purchase cost ranging from **\$3,000 to \$4,000**.
- A proposal for a **video announcement board** has been submitted to the Board. The cost for a **two-sided LED display system** is **\$36,000**, while a **single-sided LED display** is priced at **\$23,000**.

- Several air fryer options were presented to Supervisor Karen, with a recommendation for the **GE single oven**, priced at **\$1,399**. We are currently researching the cost to upgrade the electrical system and determining whether a contractor is available to modify the existing cabinetry to accommodate the unit.
- Training report due to Supervisor Young – Expectation is by the 5th of each month. Current contract language indicates reports are due by the 15th of each month. **Discussion Item**

Community Clubs and Social Groups

Residents may form clubs and social groups around similar interests and will get access to the amenities for no charge according to a schedule that is agreed upon with management. For more information on all the active clubs and social groups in Tamaya, please contact Oliver at oingram@vesatapropertyservices.com and visit TamayaAmenities.com for the application form. Please note: Clubs are created and operated by residents of Tamaya and NOT by the Beach CDD, which does not endorse or express an opinion on any Club or Social Group or on any of their activities or publications. No Tamaya Club or Social Group is considered a program of the Beach CDD in any way whatsoever. If you are interested in starting a new social club please stop by or contact the office for more information

Current Club Gathering and Times Available:

- *Travel Social* - Please contact Karen Young for more information and schedule at: youngk1001@att.net
- *Bunco* - Held the last Monday of every month at Tamaya hall at 7:00 PM. Please contact Karen Young for more information and schedule at: youngk1001@att.net
- *Lunch Brunch Chili's* – Tuesday, February 10th 11:30 AM – 1:30 PM. Please contact Paula Rodrigez for more information at: ppesci@racsystems.com
- *Chapter Chatters* – Held the last Tuesday of every month at Tamaya Hall at 6:30 PM. Please contact Becky Farinella for more info and schedule at: fourfarinellas@comcast.net

Programing

Due to recent changes and events, Emma has decided not to continue offering classes currently. She will take some time to determine whether she plans to resume her summer classes. If she decides to return, an announcement will be made to the community. Zumba with Tangie B- every Thursday 6:30-7:30 PM in the group fitness room Starting in February, Basima Salameh's Anti-Stress Yoga and Chair Yoga classes will no longer be held at Tamaya's Amenity Center in the group fitness room. She will continue offering her classes from her home, and residents may contact her directly to inquire about scheduling and availability at (716) 479-1744

Zumba

Come join the party every Thursday from 6:30 PM – 7:30 PM in the group fitness room. Zumba is a total body workout, combining all elements of fitness to include cardio, muscle conditioning, balance, flexibility, and boosting energy to the rhythmic tunes of Latin and international rhythms. It is uniquely designed to suit all fitness levels, but participants are encouraged to modify to fit

their own personal needs. Get ready for an EXHILARATING EXPERIENCE! A minimum of 5 people must sign up to hold the class. Class rates are \$8 per participant Text (352) 215-1801 to sign up!

Year at a Glance

Events subject to change due to weather or other circumstances beyond our control

We welcome your feedback and any recommendations for new events you'd like to see in the future.

March Events:

3/28/26 Easter Event

May Events:

5/02/26 Kentucky Derby

5/08/26 Cinco de Mayo

5/17/26 Storytime

5/18/26 CDD Board Meeting

5/23/26 Splash Bash

July Events:

7/03/26 Happy Hour

7/12/26 Storytime & Craft Hour

7/18/26 Hawaiian Luau

7/20/26 CDD Board Meeting

April Events:

4/10/26 Tamaya Happy Hour

4/11/26 Spring Garage Sale

4/12/26 Story Time

4/17/26 Trivia Night

4/25/26 Goat Yoga

June Events:

6/05/26 Happy Hour

6/13/26 Clark's Critter Show

6/14/26 Storytime

6/15/26 CDD Board Meeting

6/27/26 Dueling Pianos

August Events:

8/07/26 Happy Hour

8/09/26 Storytime & Craft Hour

8/15/26 Potluck

8/17/26 CDD Board Meeting

- 8/21/26 Trivia Night September_Events:
- 9/05/26 Labor Day Pool Party
- 9/13/26 Storytime & Craft Hour
- 9/21/26 CDD Board Meeting
- 9/26/26 Casino Night

YTD Special Events Budget

FY Month	Event	type	net cost	attend	cost per person	actual cost	Sponsors / total fee collect	net cost	attend	cost per person	net cost	attend	cost per person
02 - Oct	Halloween Happy Hour	adult	\$ 1,500	65	\$ 23	\$ 1,345	\$0	\$1,345	45	\$ 30	\$ 155	-20	\$ (7)
12 - Oct	Spooky Storytime	family	\$ 150	34	\$ 4	\$ 133	\$0	\$133	39	\$ 3	\$ 17	5	\$ 1
19 - Oct	Toy Story Halloween	family	\$ 3,500	212	\$ 17	\$ 3,529	\$0	\$3,529	180	\$ 20	\$ (29)	-32	\$ (3)
08 - Nov	Veterans Night Out	adult	\$ 1,000	39	\$ 26	\$ 1,100	\$0	\$1,100	32	\$ 34	\$ (100)	-7	\$ (9)
09 - Nov	Nov Storytime	family	\$ 150	23	\$ 7	\$ 180	\$0	\$180	15	\$ 12	\$ (30)	-8	\$ (5)
11 - Nov	Community of Heros	family	\$ 500	53	\$ 9	\$ 725	\$0	\$725	75	\$ 10	\$ (225)	22	\$ (0)
14 - Nov	Friendsgiving Happy Hour	adult	\$ 500	101	\$ 5	\$ 250	\$0	\$250	85	\$ 3	\$ 250	-16	\$ 2
21 - Nov	Chilli Cook-Off	family	\$ 200	58	\$ 3	\$ 52	\$0	\$52	60	\$ 1	\$ 148	2	\$ 3
05 - Dec	White Elephant Event	adult	\$ 200	40	\$ 5	\$ 168	\$0	\$168	39	\$ 4	\$ 32	-1	\$ 1
13 - Dec	Holly Jolly Christmas	family	\$ 3,000	350	\$ 9	\$ 3,185	\$250	\$2,935	350	\$ 8	\$ 65	0	\$ 0
19 - Dec	Tamaya Community	adult	\$ 3,000	213	\$ 14	\$ -	\$9,000	-\$9,000	180	\$ (50)	\$ 12,000	-33	\$ 64
20 - Dec	Christmas Storytime	family	\$ 150	24	\$ 6	\$ 110	\$0	\$110	24	\$ 5	\$ 40	0	\$ 2
09 - Jan	New Years Happy Hour	adult	\$ 1,600	83	\$ 19	\$ 1,619	\$0	\$1,619	73	\$ 22	\$ (19)	-10	\$ (3)
11 - Jan	Storytime	family	\$ 150	21	\$ 7	\$ 76	\$0	\$76	21	\$ 4	\$ 74	0	\$ 4
23 - Jan	Trivia Night	family	\$ 500	74	\$ 7	\$ 220	\$0	\$220	64	\$ 3	\$ 280	-10	\$ 3
08 - Feb	Superbowl	family	\$ 1,500	87	\$ 17	\$ 1,101	\$250	\$851	70	\$ 12	\$ 649	-17	\$ 5
15 - Feb	Storytime	family	\$ 150	30	\$ 5	\$ 106	\$0	\$106	30	\$ 4	\$ 44	0	\$ 1
28 - Feb	Movie Night at Tamaya	family	\$ 500	59	\$ 8	\$ 668	\$0	\$668	59	\$ 11	\$ (168)	0	\$ (3)
13 - Mar	Teen	family	\$ 1,800	69	\$ 26	\$ 1,900	\$0	\$1,900	100	\$ 19	\$ (100)	31	\$ 7
14 - Mar	Potluck	family	\$ 150	18	\$ 8	\$ 31	\$0	\$31	5	\$ 6	\$ 119	-13	\$ 2
22 - Mar	Storytime	family	\$ 150	28	\$ 5	\$ 85	\$0	\$85	19	\$ 4	\$ 65	-9	\$ 1
			\$ 20,350	1,681	\$ 12	\$ 16,584	\$ 9,500	\$7,084	1,565	\$ 5	\$ 13,266	-116	\$ 8

	BUDGET			ACTUAL					VARIANCE		
	cost	attend	cost per person	actual cost	total fee collect	net cost	attend	cost per person	net cost	attend	per person
family	\$ 10,450	1,025	\$ 10	\$ 10,085	\$ 500	\$7,960	987	\$ 8	\$ 365	-38	\$ 2
adults	\$ 7,800	541	\$ 14	\$ 4,482	\$ 9,000	-\$4,518	454	\$ (10)	\$ 3,318	-87	\$ 24
TOTAL	\$ 18,250	1,566	\$ 12	\$ 14,567	\$ 9,500	\$3,442	1,441	\$ 2	\$ 3,683	-125	\$ 9

EXHIBIT 4



Field Operations Managers Report

Date of report: **4.13.2026**

Submitted by: **Ron Zastrocky**

Notables & Projects

- Gate locks and spring – New hinge is on. Locks cannot be put on due to gate needing to be re-hung. *Gate post is broken on exit sidewalk. Scheduled for repair on 4/10 also moving hinges to other side so gates swing inward. RZ 4/7/26. Completed 4-10-26.*
- Refresh crosswalk painting – *Scheduled to be completed by 4/15/2026 In Progress RZ 4/7/26*
- Decals for newly painted mailboxes installed – *Completed*
- Assess sprinklers in pond that may be watering pond – *Will discuss with Greenery regarding start date 4/1. Meeting with Greenery on 4/16/26 to discuss*
- Repair speed bump at main entrance – *Scheduled for 3/31 Move completion date to 4/15. Looking at different options like asphalt.*
- Repair of speed limit sign on Tamaya Blvd – *Not CDD property. MyJax ticket opened 2/3/2026; this is the second ticket submitted.*
- Gate at entrance of breezeway conduit – *Completed*
- Roundabout – ADA yellow mats – *Need to be resecured. New mat has been ordered. Completion anticipated by 4/1. Move completion date to 4/15*
- Touch-up for columns in Amenity Center (wood filler needed) – *360 Painting is aware; completion anticipated by 4/1. Completed*
- Install existing solar lighting in breezeway area (x2) – *Will review with Oliver and provide completion date by end of week. Scheduled to be completed by 4/30/26 Met with Jim for locations. Est completion date of 4-30-26*
- Ron to check leveling of property on Karatas and confirm if trees were removed – *Will contact homeowner to request access to verify whether the issue has been rectified. In engineer's hands RZ 4/7/26*
- *Costas way river rock project underway Est completion date is 4/10/26 Completed 4-10-26*
- *Fedex truck hit lights at guard house. Est completion date is 4/10/26. Completed 4-10-26*

EXHIBIT 5

Date of Action Item	Action Item	Status
	Field Operations Manager Section	
8/7/2025	FOM to research what needs to be done with pool pavers (repair needs if artificial turf is also to be installed)	On Hold 3.12.2026 Update: in the process of acquiring quotes.
9/15/2025	FOM to inspect burned out lights around pool and remove mulch from around them	Done
12/4/2025	FOM to obtain additional quotes for inside painting of Tamaya Hall	Done
12/4/2025	FOM to obtain additional quotes for drainage on Costas Way	3.12.2026 Update: Greenery will start on 4/1
12/4/2025	FOM and AM obtain quotes for mirrors in group fitness/yoga rooms	3.12.2026 Update: Need direction from BOS in March Meeting on what size of mirrors are needed in order to acquire quote.
12/4/2025	FOM obtain quote for construction of identified alternative storage area	Underway following additional BOS Directive
12/15/2025	FOM to obtain bids to replace tables in pool area	3.12.2026 Update: Spoke with Sup. Young for discussion at March meeting. Looking at Southern Breeze.
12/15/2025	FOM to check operation ability of new pedestrian gates	3/5/2026 workshop: move to inside; add spring closer. 3.12.2026 Update: New hinges have been installed so that now it is self-closing.
1/8/2026	FOM to request Ruppert Landscape trim cord grasses and shrubbery at Meritage Roundabout and intersection of Meritage & Cassia ASAP	3.12.2026 Update: Core grasses have been trimmed back. Will look to trim back shrubbery when new vendor is in place 4/1.

2/5/2026	FOM to check proximity of lights via JAX ordinance and obtain number of trees to remove and quote for removal	3.12.2026 Update: Have reached out to city member with no results, will continue to follow up.
2/5/2026	FOM to discuss with The Greenery, Inc. ideas about creating a “serpentine” area so that if needed residents can exit in this path.	3.12.2026 Update: everything has been completed except for another way to exit for emergency purposes
2/9/2026	FOM to place additional lighting on parking lot side of Tamaya Hall	3.12.2026 Update: Staff reviewing area to ensure the lighting that is installed is in the proper area.
2/9/2026	FOM to speak with JEA about multiple locks on JEA gate	Underway
2/9/2026	FOM to show Supervisor Young paint color and stain colors being used in Tamaya Hall	Done
3/5/2026	FOM to contact district supervisors’ office regarding city contact for arborist	3.12.2026 Update: Have reached out to city member with no results, will continue to follow up. This is a duplicate with 2/5/2026 task above
3/5/2026	FOM to refresh pedestrian crossings	3.12.2026 Update: Underway to be completed by 3/15.
3/16/2026	FOM to obtain information on mirrors in group fitness/yoga room	
4/2/2026	FOM to obtain references for Solitude Lake Management for 5/7/2026 workshop	
Amenity Manger Section		
6/16/2025	AM and FOM to get a quote from AT&T for internet service	3.12.2026 Update: Working on contract now

8/18/2025	AM to attempt to locate a swim school who do not rely on college students as instructors	Done
12/4/2025	AM and FOM obtain quotes for mirrors in group fitness/yoga rooms	3.12.2026 Update: Need direction from BOS in March Meeting on what size of mirrors are needed in order to acquire quote.
12/15/2025	AM to establish a chart (including measurements) showing locations of table and chair locations in Tamaya Hall.	3.12.2026: pending arrival of new furniture
2/5/2026	AM to send out survey regarding pickleball courts and have results for the March workshop	Done
2/5/2025	AM to send out an E-Blast and Post Flyer in Breezeway regarding Summer Severe Weather Suggestions	Done
2/5/2025	AM to obtain updated quotes from the British Swim School	Done
3/5/2026	AM to provide information to Supervisor Young on Air Fryer	3.12.2026 Update: Underway
4/2/2026	AM to obtain additional information on digital sign for 5/7/2026 workshop	
4/2/2026	AM to send out an E-Blast on or about 4/27 regarding Furniture Sale	
	District Manager Section	
3/17/2025	DM to send Mike V. email on pending projects after each meeting	Done
7/21/2025	DM to contact DE and obtain a proposal for work to be done on Bastia Court for drainage problem	7/22: Email to Scott; 8/23: Follow up email sent
2/5/2026	DM to discuss with DE the feasibility of a truck entrance lane at Gate House	
2/9/2026	DM to speak with Mike V. regarding Parcel #7	Done

2/9/2026	DM to send DC the C&D letter sent to the recent resident	Done
2/9/2026	DM to send Vice Chair and Supervisor Repak the excel budget document handed out at meeting	Done
4/2/2026	DM to send to Board Dr. Renn's report regarding Street Trees	Done
4/2/2026	DM to send email to RAMCO regarding pushing both gate arm and entry gate buttons	Done
	District Engineer Section	
2/19/2024	DE to inquiry as to COJ maintaining west side of Tamaya Boulevard	2/26/2024: Initial internal response from DE
5/20/2024	DE to determine and report back to Board what needs to be done with respect to turning landscape maintenance of Tamaya Boulevard over to COJ (e.g. does landscape and irrigation need to be removed before COJ will take over the maintenance of the roadway)	Needs to be returned to sod and possibly trees
2/5/2026	DE to evaluate gate entrance for a Truck Gate	
	District Counsel Section	
10/20/2025	DC to write letter to Holland	Underway
2/9/2026	DC to send letter to resident who expanded into District property	Done
3/16/2026	DC to provide contracts for items passed during 3/16/2026 meeting	Done
	Board of Supervisors Section	

7/3/2025	Supervisor Young to email DC to check if it is possible to limit TekControl contact to adults only (so children cannot have access)	Underway
7/3/2025	Supervisor Young to check with TekControl to see if access to the app could be limited to adults only	Underway
7/3/2025	Vice Chair Szeszko to email DM the quote on the night lighting assessment for the pool	
10/2/2025	Supervisor Repak to contact COJ CC regarding speed bumps, speed device and JSO	
2/5/2026	Vice Chair Szeszko to revise current janitorial contract to include guard house cleaning	

EXHIBIT 6

BEACH CDD MEETING AGENDA MATRIX

May 2026	<p>Workshop 5/7</p>	<p><i>Presentations</i></p> <p><i>Upcoming Business Item</i></p> <ul style="list-style-type: none"> • 1. Pond Maintenance Proposal Options <ul style="list-style-type: none"> ○ 1a. Current Contract – The Lake Doctors - \$2,369.00/month ○ 1b. Charles Aquatics - \$2,200/month ○ 1c. Solitude Lake Management - \$2,000/month (\$1,810/month with a 3 yr. Contract) <p><i>Supervisor Projects</i></p> <p><u>Chair Kendig</u></p> <ul style="list-style-type: none"> • 1. Arborist/Options for Oak Trees • 2. Mirrors in Yoga/Group Fitness Room • 3. Truck Gate Entrance (from 1/12/2026 meeting) • 4. Digital Signage Options • 5. Tarps for Playground and Palm Court <p><u>Supervisor Young</u></p> <ul style="list-style-type: none"> • 1. Capital Improvement Plan Projects <ul style="list-style-type: none"> ○ 1a. Re-Marcite Coating • 2. Air Fryer Capable Warming Oven (Tamaya Hall) • 3. Tamaya Hall Renovation Proposal Options <ul style="list-style-type: none"> ○ 3a. 360 Painting--\$4,489.63 ○ 3b. (2nd Quote Needed) ○ 3c. (3rd Quote Needed) • 4. Roving Patrol vs. CCTV <p><u>Vice Chair Szeszko</u></p> <ul style="list-style-type: none"> • 1. 2027 Preliminary Budget—Line by Line Discussion • 2. Gate Access Control—TEK Control Research • 3. Pedestrian Crosswalk—TBD, District Engineer <p><u>Supervisor Repak</u></p> <ul style="list-style-type: none"> • 1. Gate Access Control • 2. Security • 3. Proposed Rules Changes for Property and Personal Safety 	<ul style="list-style-type: none"> • 1a. Exhibit 7 from the 4/2/2026 workshop • 1b. Exhibit 8 from the 4/2/2026 workshop • 1c. Exhibit 9 from the 4/2/2026 workshop <ul style="list-style-type: none"> • 1. Exhibit 14 from 2/5 workshop • 1. Ron to obtain quotes for removal of certain trees • 2. Awaiting proposal from 360 Painting • 3. Waiting for new DE to start • 4. Two exhibits emailed to Jackie on 3/15 <ul style="list-style-type: none"> • 3. 4/8: Exhibit emailed to Jackie
----------	--------------------------------	---	---

BEACH CDD MEETING AGENDA MATRIX

		<p><u>Supervisor Caprita</u></p> <ul style="list-style-type: none">1. Timing of Irrigation Cycles, Irrigation Inspection Reports and Irrigation Inspections <p><i>Pending from Prior Workshop(s)</i></p> <p><i>Discussion Items</i></p> <ul style="list-style-type: none">1. Alternatives to Secure Area to Prevent Jumping of Fence from the 4/2/2026 Workshop—Supervisor Young <p><i>Future Workshop</i></p>	
--	--	--	--

BEACH CDD MEETING AGENDA MATRIX

<p style="text-align: center;"><i>May 2026</i></p>	<p style="text-align: center;"><i>Regular Meeting: 5/18</i></p>	<p><i>Vendor Reports</i></p> <p><i>Presentations</i></p> <p><i>Consent Agenda Items</i></p> <ul style="list-style-type: none">• 1. Minutes<ul style="list-style-type: none">○ 1a. Workshop—5/7/2026○ 1b. Regular Meeting—4/20/2026• 2. Unaudited Financials<ul style="list-style-type: none">○ 2a. April 2026 <p><i>Business Items</i></p> <p><i>Discussions</i></p> <p><i>Staff Reports</i></p> <ul style="list-style-type: none">• District Manager<ul style="list-style-type: none">○ 1. Resident(s) Subject to Disciplinary Action○ 2. Incident Report Tracker○ 3. Action Item Report○ 4. Meeting Matrix• District Counsel• District Engineer	
--	---	--	--

BEACH CDD MEETING AGENDA MATRIX

<i>Unscheduled Items</i>		<p><i>Presentations</i></p> <p><i>Consent Agenda Items</i></p> <p><i>Business Items</i></p> <p><i>Discussions (Workshop)</i></p> <p><i>Public Hearing</i></p> <p><i>Vendor Reports</i></p> <p><i>Closed Session</i></p> <ul style="list-style-type: none">• Gate Access Control Post Orders	
--------------------------	--	---	--

BEACH CDD MEETING AGENDA MATRIX

MAJOR CONTRACT VENDOR NAME/SERVICE	EXPIRATION DATE/COMMENTS
AED Lease-Purchase/Cintas	Ending 11/2026
Amenity Management/Vesta Property Services	9/30/2028 (60 days)
Aquatic Management/Lake Doctors	10/1/2025-9/30/2026 (30 days)
Arbitrage Services/LLS Tax Solutions	2024 Series: Period ending 7/16/2026; 2015 Series : Period ending 5/5/2027
Audit Services/DMHB	Fiscal Year ending 9/30/2029
Criminal Background Checks/Screening One	3/15/2023-1 year auto renewal
District Counsel Services/Kutak Rock LLP	12/27/2022-
District Engineer Services/England-Thims & Miller, Inc.	Period ending 9/30/2025
District Management Services/DPFG (d/b/a Vesta District Services)	5/1/2022- 9/30/2023-1 year auto renewal
Fire Alarm Monitoring & Inspection/Wayne Automatic Fire Sprinklers, Inc.	12/30/2025-12/30/2026-auto renews for 1 year four times (60 days for failure to perform; 30 days without cause)
Gym Equipment Lease/American Capital	10/1/2023-9/30/2028
Janitorial Services—Quality Cleaning by Viktoriia LLC	4/1/2026 – 3/31/2027 1 year auto renewal (30 days)
Landscape Maintenance/The Greenery Inc.	4/1/2026- 3/31/2027—auto renew for 2 consecutive 1 year terms (30 days for failure to perform; 30 days without cause)
Pest Control/Turner Pest Control	3/23/2017-
Phone/Internet Service—AT&T	3/19/2026-3/24/2029
Refuse Removal/GFL Environmental)	10/1/2028 (auto renewal for 3 years--no less than 90 days notice)

BEACH CDD MEETING AGENDA MATRIX

Security Guard Service/RAMCO Protective of Orlando, Inc.	4/1/2026-3/31/2027- (30 days)
Towing Service/Adkinson Towing	5/1/2025-
Vending Machine Services/Purpose Vending	3/31/2025-
Website Hosting/Campus Suite	4/1/2022-9/30/2022; 1 year auto renewal

EXHIBIT 7

1 **3MINUTES OF MEETING**

2 **BEACH**

3 **COMMUNITY DEVELOPMENT DISTRICT**

4 The Regular Meeting of the Board of Supervisors of the Beach Community Development District
5 was held on Monday, March 16, 2026 at 6:00 p.m., at 12788 Meritage Blvd., Jacksonville, FL 32246.

6 **FIRST ORDER OF BUSINESS – Roll Call**

7 Supervisor Kendig called the meeting to order and conducted roll call.

8 Present and constituting a quorum were:

- | | | |
|----|---------------|---------------------------------------|
| 9 | James Kendig | Board Supervisor, Chairman |
| 10 | Pawel Szeszko | Board Supervisor, Vice Chairman |
| 11 | Karen Young | Board Supervisor, Assistant Secretary |
| 12 | Todd Caprita | Board Supervisor, Assistant Secretary |
| 13 | Walter Repak | Board Supervisor, Assistant Secretary |

14 Also, present were:

- | | | |
|----|------------------------------|---|
| 15 | David McInnes | District Manager, Vesta District Services |
| 16 | Wes Haber <i>(via phone)</i> | District Counsel, Kutak Rock |
| 17 | Oliver Ingram | Amenity Manager, Vesta Property Services |
| 18 | Ron Zastrocky | Field Operations Manager, Vesta Property Services |
| 19 | Jason Davidson | Regional General Manager, Vesta Property Services |
| 20 | Pawel Szeszko | Resident |
| 21 | Jasleen Raina | Resident |
| 22 | David Putnam | Resident |
| 23 | Carole Repak | Resident |

24
25 *The following is a summary of the discussions and actions taken at the March 16, 2026 Beach CDD Board*
26 *of Supervisors Regular Meeting. Audio for this meeting is available upon public records request by*
27 *emailing PublicRecords@vestapropertyservices.com.*

28 **SECOND ORDER OF BUSINESS – Pledge of Allegiance**

29 Supervisor Kendig led all present in reciting the Pledge of Allegiance.

30 **THIRD ORDER OF BUSINESS – Audience Comments – (limited to 3 minutes per individual for agenda**
31 *items)*

32 Pawel Szeszko, as a resident, discussed that the off-duty roving patrol provided by JSO and paid
33 for by the CDD was not necessary due to the low crime rates within Tamaya.

34 Jasleen Raina discussed the continued non-compliance of remediation by a resident from non-
35 approved construction. Mr. McInnes provided an update. Supervisor Repak provided comments
36 based on conversations he'd had with Mr. McInnes on the matter. Discussion ensued regarding
37 whether a lien can be placed on a homeowner's property based on cost of damages done to District
38 property with District Counsel providing input on the matter, as well as how to best handle the
39 remediation of the conservation area. This topic will be further discussed at the next workshop.

40 **FOURTH ORDER OF BUSINESS – Exhibit 1: Presentation of Proof of Publication(s)**

41
42

43 **FIFTH ORDER OF BUSINESS – Vendor Reports**

44 A. The Greenery, Inc. – Client Communication Report

45 During the District Engineer section of the agenda, the Board requested that The Greenery, Inc.
46 provide them with weekly landscape updates via email.

47 B. Vesta Property Services

48 1. Exhibit 2: Lifestyle Management Report

49 2. Exhibit 3: Field Management Report

50 **SIXTH ORDER OF BUSINESS – Staff Reports**

51 A. District Counsel

52 1. Exhibit 4: Review of Alliant Engineering, Inc. Proposed Contract and Rates

53 Mr. Haber provided a brief overview of the proposed contract. The Board requested that the
54 contract state that the District Engineer need only attend meetings when requested by the
55 Board.

56 On a MOTION by Mr. Repak, SECONDED by Ms. Young, WITH ALL IN FAVOR, the Board approved
57 the proposed contract and associated rates with Alliant Engineering, Inc. and directed District Counsel
58 notify ETM of the contract termination for District Engineering Services to be effective in 90 days, for the
59 Beach Community Development District.

60 B. District Engineer

61 The District Engineer was not present.

62 C. District Manager

63 Mr. McInnes asked the Board if they would like to hold a workshop just to discuss the FY 2027
64 budget. A budget workshop was not scheduled at this time.

65 1. Resident(s) Subject to Disciplinary Action

66 2. Complaint & Incident Management Tracker

67 3. Exhibit 5: Action Item Report

68 4. Exhibit 6: Meeting Matrix

69 **SEVENTH ORDER OF BUSINESS – Consent Agenda**

70 A. Exhibit 7: Consideration for Approval – The Minutes of the Board of Supervisor Regular Meeting
71 Held on February 9, 2026

72 B. Exhibit 8: Consideration for Approval – The Minutes of the Board of Supervisors Workshop Held
73 on March 5, 2026

74 C. Exhibit 9: Consideration for Acceptance – The January 2026 Unaudited Financial Statements

75 D. Exhibit 10: Consideration for Acceptance – The February 2026 Unaudited Financial Statements

76 E. Ratification of Board’s Decision to Keep Resident’s Side of Exit Gate Opened from 7:00 AM-9:00
77 AM Monday-Friday—from the 3/5/2026 Workshop

78 F. Exhibit 11: Ratification of The Greenery, Inc. Proposal for Phase IV Treatment from the 3/5/2026
79 Workshop - \$1,474.37 (Landscaping; GF; Line 32)

- 80 G. Exhibit 12: Approval of the Prime Stone Restoration Proposal from the 3/5/2026 Workshop -
81 \$1,490.00 (Community and Amenity Repairs; GF; Line 38)
- 82 H. Exhibit 13: Approval of the 360 Painting Proposal for Prep and Repainting of Pool Spiral Staircase
83 from the 3/5/2026 Workshop - \$10,772.96 (CIP-Future FY; CRF; Line 8)
- 84 I. Exhibit 14: Approval of the 360 Painting Proposal for the Breezeway from the 3/5/2026 Workshop
85 - \$2,519.27 (CIP-Future FY; CRF; Line 8)
- 86 J. Exhibit 15: Approval of the 10-s Tennis Supply & Dinkshot Pickleball Clay for Tennis Courts
87 Installation Proposal from the 3/5/2026 Workshop – 3 Pallets for \$3,049.24 (Tennis Court
88 Maintenance; GF; Line 55)
- 89 K. Approval for Supervisor Young to Have a Spending Limit of \$500 tp Purchase Items for the
90 Amenity Center

91 On a MOTION by Mr. Kendig, SECONDED by Mr. Szeszko, WITH ALL IN FAVOR, the Board approved
92 the Consent agenda as presented, for the Beach Community Development District.

93 **EIGHTH ORDER OF BUSINESS – Business Items**

- 94 A. Exhibit 16: Consideration of Acceptance of Parcel #7 from Tamaya Loan Acquisition LLC via
95 Special Warranty Deed
- 96 Mr. McInnes provided a brief reminder of what the item was.

97 On a MOTION by Mr. Kendig, SECONDED by Ms. Young, WITH ALL IN FAVOR, the Board accepted
98 Parcel #7 from Tamaya Loan Acquisition LLC via a Special Warranty Deed, for the Beach Community
99 Development District.

- 100 B. Exhibit 17: Consideration of RAMCO Protective Services Proposed Rates for Gate Access Control
101 (Guard Service; GF; Line 62)
- 102 Mr. McInnes provided a brief explanation.

103 On a MOTION by Mr. Kendig, SECONDED by Mr. Caprita, WITH ALL IN FAVOR, the Board approved
104 the RAMCO Protective Services for a 1-Year contract, for the Beach Community Development District.

- 105 C. Exhibit 18: Consideration of the Life Fitness Proposal for an Abduction/ Adduction Machine for
106 \$4,296.65 and the Proposal for a Back Extension for \$1,568.25 from the 3/5/2026 Workshop
107 (Contingency; CRF; Line 9)
- 108 Supervisor Kendig provided a brief explanation. Discussion ensued.

109 On a MOTION by Mr. Kendig, SECONDED by Mr. Caprita, WITH Mr. Szeszko and Mr. Repak voting
110 ‘yay’ and Ms. Young voting ‘nay’, the Board approved the purchase of an Abduction/Adduction Machine,
111 in the amount of \$4,296.65, and a Back Extension Machine, in the amount of \$1,568.25, for the Beach
112 Community Development District.

- 113 D. Consideration to Reverse Board Decision Made on 2/9/2026 to Amend Current Agreement with
114 Vlademyros Mavropoulos-Stoliarenko to Apply to Residents Only Effective 4/1/2026

115
116

117 On a MOTION by Mr. Kendig, SECONDED by Mr. Repak, WITH Mr. Szeszko and Mr. Caprita voting
118 'yay' and Ms. Young voting 'nay', the Board rescinded the decision from the 02/09/2026 meeting
119 restricting tennis clinics and campus to Tamaya residents only and authorized the District Manager to
120 inform the instructor accordingly, for the Beach Community Development District.

121 E. Exhibit 19: Consideration of Quality Cleaning by Viktoriia (w/ Revised Scope of Work) Proposal
122 from the 1/8/2026 Workshop (Amenity Cleaning; Line 49) - \$2,290.00/month (05/01-08/31) &
123 \$1,760.00/month (09/01-04/30)
124 Supervisor Szeszko provided a brief explanation and noted that it did not include the
125 \$230.00/month to clean the guardhouse once a week.

126 On a MOTION by Mr. Szeszko, SECONDED by Mr. Kendig, WITH ALL IN FAVOR, the Board approved
127 the Quality Cleaning by Viktoriia contract with a revised scope of work, for the Beach Community
128 Development District.

129 F. Exhibit 20: Consideration of AT&T Proposal for Amenity Center and Gate Guard House (Amenity
130 Internet/Cable; GF; Line 52)
131 Supervisor Szeszko provided a brief explanation. Discussion ensued.

132 On a MOTION by Mr. Kendig, SECONDED by Mr. Szeszko, WITH ALL IN FAVOR, the Board approved
133 the AT&T proposal for internet and phone services for the Amenity Center and the Guard House with the
134 understanding that the District would obtain their own equipment rather than use the Cisco equipment
135 provided by AT&T, and to terminate the contract with Comcast/Infinity upon complete installation of the
136 AT&T service, for the Beach Community Development District.

137 G. Exhibit 21: Consideration of Lucas Tree Proposal for Cutting of 3 Trees -\$1,300.00 (Community
138 and Amenity Repairs; GF; Line 38)
139 Mr. Zastrocky provided a brief explanation.

140 On a MOTION by Mr. Kendig, SECONDED by Mr. Szeszko, WITH ALL IN FAVOR, the Board approved
141 the Lucas Tree proposal, in the amount of \$1,300.00, for the Beach Community Development District.

142 H. Exhibit 22: Consideration of Revised Tamaya Facility Rental Agreement
143 Supervisor Young presented the possible changes for Board approval. Discussion ensued.

144 On a MOTION by Mr. Szeszko, SECONDED by Ms. Young, WITH ALL IN FAVOR, the Board approved
145 the Revised Tamaya Facility Rental Agreement, as amended, for the Beach Community Development
146 District.

147 **NINTH ORDER OF BUSINESS – Discussion Topics**

- 148 A. Water Slide Operating Hours from the 3/5/2026 Workshop – Chair Kendig
149 This item was moved to the 04/02/2026 workshop.
150 B. TEKWave Solutions New Pricing—Effective 5/1/2026--\$7,279 per year

151 **TENTH ORDER OF BUSINESS – Supervisors' Requests**

152 There being no Supervisors' requests, the next item followed.

153 **ELEVENTH ORDER OF BUSINESS – Audience Comments – New Business/Non-Agenda** *(limited to*
154 *3 minutes per individual)*

155 David Putnam complimented the paint job on the mailboxes and also provided a comment from the HOA
156 Vice President regarding the common areas.

157 **TWELFTH ORDER OF BUSINESS – Action Items Summary**

158 FOM to obtain information regarding mirrors in the group fitness/yoga room

159 **THIRTEENTH ORDER OF BUSINESS – Meeting Matrix Summary**

160 Water Slide Operating Hours

161 Enforcement Action Options

162 **FOURTEENTH ORDER OF BUSINESS – Next Workshop Confirmation or Cancellation: April 2**
163 **at 6:00PM**

164 Confirmed

165 **FIFTEENTH ORDER OF BUSINESS – Next Meeting Quorum Check: April 20 at 6:00 PM**

166 All five Board members stated that they would be attending the next Board meeting on April 20 at
167 6:00 p.m.

168 **SIXTEENTH ORDER OF BUSINESS – Adjournment**

169 Mr. McInnes asked for final questions, comments, or corrections before requesting a motion to
170 adjourn the meeting. There being none, Mr. Kendig made a motion to adjourn the meeting.

171 On a MOTION by Mr. Kendig, SECONDED by Mr. Repak, WITH ALL IN FAVOR, the Board adjourned
172 the meeting at 7:06 p.m. for the Beach Community Development District.

173 **Each person who decides to appeal any decision made by the Board with respect to any matter considered*
174 *at the meeting is advised that person may need to ensure that a verbatim record of the proceedings is made,*
175 *including the testimony and evidence upon which such appeal is to be based.*

176 **Meeting minutes were approved at a meeting by vote of the Board of Supervisors at a publicly noticed**
177 **meeting held on April 20, 2026.**

178
179
180
181

Signature

Signature

Printed Name

Printed Name

182 **Title:** **Secretary** **Assistant Secretary**

Title: **Chairman** **Vice Chairman**

EXHIBIT 8

Thursday April 2, 2026, Workshop 6:00-9:00 p.m.

Roll Call.

Kendig, Szeszko, Young, Repak, Caprita were all present.

Audience Comments – None

Presentation by Jim from Florida Waterways, Inc

Upcoming Business

Pool Area Tables, etc.

- Consent agenda for approval of Southern Breeze Option 3 at \$14,486.77 and \$39,054.55 plus 2 additional tables and 8 chairs.

Pond Maintenance

- Hold for next workshop to provide Ron to obtain references regarding Solitude Lake Management.

Paver Proposal

- Consent agenda – approve 360 Painting \$6,286.00

Kendig

Arborist – email from Robert Renn to be distributed by David and JAX has been contacted and referred to another city dept.

Mirrors in Fitness Room – Ron still working on proposal.

Truck Gate Ent – waiting for new Dist. Eng to be onboard.

Ice Machine – consent agenda – NTE \$12,000.00 w/installation. Oliver to find a slightly smaller unit 250-350 lbs. and to be placed in Palm Court Building.

Digital Sign – board would like to see additional smaller samples. Move to next workshop.

Water Slide Hours of Operation – consent agenda:

Monday – closed

Tuesday – Friday 12 to 7pm

Sat, Sun, Hol – 10 to 7pm

Szeszko

Swim Lessons – closed issue. British Swim School however Oliver notified the board that the aquatics instructor has opted not to return.

Post Orders – consent agenda, if required.

David – please remind RAMCO staff to press both the arm and gate buttons when allowing access via the visitor lane.

Morgan Inglad LLC proposal was reviewed – consent agenda for NTE \$25,000.

PEDS crosswalk – on hold.

Review of budget was discussed.

Young

Remarcite of pool was discussed for 2027. To be completed in December or January using TemPools.

Air Fryer – waiting for Oliver and proposals.

Tamaya outside storage bldg. – have 360 at next workshop to discuss.

Karen reported another episode of kids jumping the fence – discuss at next workshop – alternatives to secure this area.

Business Discussion – replacing Breezeway staff with Highline Security. Check in no longer required.

Rental application and Amenity Policy remove requirement for additional staff for events with over 25 individuals – consent agenda if required.

Furniture sale – Oliver to send an e-blast on or around April 27 to residents.

Additional Blinds for large room discussed but not approved.

It was noted that there has not been an 'adult' event for approximately two (2) months. Cull story time due to lack of participation. Move 'family' events and at least 1 adult event per month. Consent agenda if required.

Consent agenda if required – require individuals to be 21 (vs 18) to attend adult events.

Gates near guard house damaged – on Ron's list repair and change direction fo swing.

Irrigation – increase frequency.

Caprita

Spoke about failing wall in his backyard – David and Wes to address at next meeting.

Repak – Nothing to report.

General discussion – e-bikes and kids using them to damage event lawn and playground mulch. Policy indicates not permitted to have ebikes in either location. Start to hold individuals accountable for damage.

~~Enforcement Action Options~~

~~Consideration of Ramco Equipment and Payment Options~~

EXHIBIT 9

Beach
Community Development District

Financial Statements
(Unaudited)

March 31, 2026



Beach CDD
Balance Sheet
March 31, 2026

	General Fund	Reserve Fund	Debt Service 2015A	Debt Service 2024	Total
1 ASSETS					
2 VNB Operating Account	2,803,221	-	-	-	2,803,221
3 BU Clover Account	37,565	-	-	-	37,565
4 SS Checking Account	68,583	-	-	-	68,583
5 BU CRF Money Market Account	-	315,404	-	-	315,404
6 Debt Service Accounts:					
7 Debt Service	-	-	-	1	1
8 Sinking Fund	-	-	19	29	49
9 Interest Fund	-	-	2	60	62
10 Redemption Fund	-	-	1	1	2
11 Prepayment Fund	-	-	19,082	13,579	32,662
12 Revenue Fund	-	-	581,020	647,787	1,228,806
13 Reserve Fund	-	-	-	165,209	165,209
14 Op Redemption Fund	-	-	1	1	2
15 Acq & Cons	-	-	1	1	2
16 Cost Of Issuance	-	-	-	-	-
17 Rebate	-	-	1	1	2
18 Accounts Receivable	-	-	-	-	-
19 Assessments Receivable On-Roll	62,479	12,196	16,685	19,092	110,451
20 Assessments Receivable Off-Roll	-	-	-	-	-
21 Due From Other Funds	-	286,805	4,280	4,897	295,982
22 Undeposited Funds	-	-	21,931	25,095	47,027
23 Prepaid	7,408	-	-	-	7,408
24 TOTAL ASSETS	2,979,257	\$ 614,404	\$ 643,023	\$ 875,753	\$ 5,112,438
25 LIABILITIES					
26 Accounts Payable	66,938	\$ 20,213	\$ -	\$ -	\$ 87,151
27 Accrued Expense	66,138	-	-	-	\$ 66,138
28 Deferred Revenue On-Roll	62,479	12,196	16,685	19,092	\$ 110,451
29 Deferred Revenue Off-Roll	-	-	-	-	\$ -
30 Due To Other Funds	295,982	-	-	-	\$ 295,982
31 TOTAL LIABILITIES	491,537	32,408	16,685	19,092	559,721
32 FUND BALANCE					
33 Nonspendable	-	-	-	-	-
34 Prepaid & Deposits	7,408	-	-	-	7,408
35 Capital Reserves	-	-	-	-	-
36 Operating Capital	364,639	-	-	-	364,639
37 Unassigned	2,115,673	581,996	626,339	856,662	4,180,670
38 TOTAL FUND BALANCE	2,487,720	581,996	626,339	856,662	4,552,717
39 TOTAL LIABILITIES & FUND BALANCE	\$ 2,979,257	\$ 614,404	\$ 643,023	\$ 875,753	\$ 5,112,437.88

Beach CDD
General Fund
Statement of Revenue, Expenditures, and Changes in Fund Balance
For the period from October 1, 2025 to March 31, 2026

	FY 2026 Adopted Budget	FY 2026 Month of March	FY 2026 Total Actual Year-to-Date	VARIANCE Over (Under) to Budget	% Actual YTD / FY Budget
1 REVENUES					
2 Assessments On-Roll	\$ 2,156,924	\$ 16,026	\$ 2,094,445	\$ (62,479)	97%
3 Interest Revenue	-	8,218	44,722	44,722	
4 Other Financing Sources	-	5,497	27,712	27,712	
5 TOTAL REVENUES	\$ 2,156,924	\$ 29,741	2,166,879	\$ 9,955	100%
6 Fund Balance Forward	\$ 30,908				
7 TOTAL REVENUES & BALANCE FORWARD	\$ 2,187,832	\$ 29,741	2,166,879	\$ (20,953)	99%
8 EXPENDITURES					
9 GENERAL & ADMINISTRATIVE EXPENSES					
10 Trustee Fees	\$ 8,800	\$ -	\$ 4,033	\$ (4,767)	46%
11 Supervisor Fees-Regular Meetings	12,000	400	2,400	(9,600)	20%
12 Supervisor Fees-Workshops	12,000	400	2,400	(9,600)	20%
13 District Management	46,790	3,899	23,395	(23,395)	50%
14 Engineering	5,460	-	1,197	(4,263)	22%
15 Dissemination Agent	2,785	-	2,785	-	100%
16 District Counsel	28,350	-	3,117	(25,233)	11%
17 Assessment Administration	6,127	511	3,063	(3,064)	50%
18 Arbitrage Rebate Calculation	676	-	650	(26)	96%
19 Audit	3,650	-	-	(3,650)	0%
20 Website	2,800	90	2,055	(745)	73%
21 Legal Advertising	3,500	200	2,073	(1,428)	59%
22 Dues, Licenses & Fees	175	-	175	-	100%
23 General Liability Insurance	68,000	-	53,522	(14,478)	79%
24 Office Miscellaneous	3,822	(67)	1,478	(2,344)	39%
26 Bonus/Appreciation Gifts	1,000	-	-	(1,000)	0%
27 District Contingency	16,303	-	-	(16,303)	0%
28 TOTAL GENERAL & ADMINISTRATIVE EXPENSES	222,238	5,433	102,343	(119,895)	46%
29 FIELD EXPENSES					
30 Field Management	178,310	-	76,443	(101,867)	43%
31 Lake Maintenance	30,000	2,369	14,214	(15,786)	47%
32 Landscaping (Including Materials)	400,000	34,543	201,814	(198,186)	50%
33 Field Operations Contingency	100,000	-	-	(100,000)	0%
34 Landscape Improvement	20,800	-	-	(20,800)	0%
35 Mulch and Pine Straw	34,944	2,220	2,220	(32,724)	6%
36 Irrigation (Repairs)	4,368	-	-	(4,368)	0%
37 Utilities/Sewers/Propane Gas	305,550	13,660	91,575	(213,975)	30%
38 Community and Amenity Repairs	90,000	4,919	44,706	(45,294)	50%
39 Sidewalk Repairs	7,000	-	-	(7,000)	0%
40 TOTAL FIELD EXPENSES	1,170,972	57,712	430,973	(739,999)	37%
41 AMENITY EXPENSES					
42 Amenity Management	156,655	-	71,672	(84,983)	46%
43 Lifeguard	28,028	-	-	(28,028)	0%
44 Amenity/Fitness Center Staffing	89,114	-	16,511	(72,603)	19%
45 Swimming Pool Chemicals	20,802	1,776	8,046	(12,756)	39%
46 Pool/Entry Water Feature Maintenance	32,725	-	961	(31,764)	3%
47 Swimming Pool Inspection	929	-	-	(929)	0%
48 Holiday Decorations	10,400	-	11,465	1,065	110%
49 Amenity Cleaning	41,200	1,680	10,899	(30,301)	26%
50 Amenity Gates/Control Access/Amenity Gate Repair	27,872	675	2,122	(25,750)	8%
51 Amenity Website/Computer Equipment	10,400	-	2,856	(7,544)	27%
52 Amenity Internet/Cable	14,560	-	4,309	(10,251)	30%

	FY 2026 Adopted Budget	FY 2026 Month of March	FY 2026 Total Actual Year-to-Date	VARIANCE Over (Under) to Budget	% Actual YTD / FY Budget
53 Fitness Equipment Lease	18,500	1,540	9,240	(9,260)	50%
54 Lifestyles Programming	46,036	1,300	19,757	(26,279)	43%
55 Tennis Court Maintenance - 4 Clay Courts	3,770	-	29	(3,741)	1%
56 Pest Control	1,747	127	748	(999)	43%
57 Amenity Fire System Monitoring	1,556	150	1,275	(281)	82%
58 AED Lease	1,810	154	924	(886)	51%
59 Trash Collection	2,983	205	1,373	(1,610)	46%
60 TOTAL AMENITY EXPENSES	509,087	7,607	162,187	(346,900)	32%
61 ACCESS CONTROL /GATE HOUSE					
62 Guard Service (Gate Only)	192,172	-	98,074	(94,098)	51%
63 Roving Guard Service	37,123	-	7,007	(30,116)	19%
65 Security Contingency	50,000				
66 Bar Code Expense	6,240	-	1,470	(4,770)	24%
67 TOTAL ACCESS CONTROL/GATE HOUSE EXPENSES	285,535	-	106,551	(178,984)	37%
68 TOTAL EXPENDITURES	2,187,832	70,752	802,053	(1,385,779)	37%
69 REVENUE OVER (UNDER) EXPENDITURES	(30,908)	(41,011)	1,364,826	1,395,734	
70 OTHER FINANCING SOURCES & USES					
71 Transfers In	-	-	-	-	
72 Transfers Out	(274,921)	-	-	274,921	
73 TOTAL OTHER FINANCING SOURCES & USES	(274,921)	-	-	274,921	
74 NET CHANGE IN FUND BALANCE	(305,829)	(41,011)	1,364,826	1,670,655	
75 Fund Balance - Beginning	476,519		1,122,894	646,375	
76 Fund Balance Forward	(30,908)				
77 FUND BALANCE - ENDING - PROJECTED	\$ 170,690		\$ 2,487,720	\$ 2,317,030	
78 ANALYSIS OF FUND BALANCE					
79 NONSPENDABLE					
80 PREPAID & DEPOSITS	886		7,408		
81 CAPITAL RESERVES	-		-		
82 OPERATING CAPITAL	364,639		364,639		
83 UNASSIGNED	(194,835)		2,115,673		
84 TOTAL FUND BALANCE	\$ 170,690		\$ 2,487,720		

Beach CDD
Capital Reserve Fund (CRF)
Statement of Revenue, Expenditures, and Changes in Fund Balance
For the period from October 1, 2025 to March 31, 2026

	FY 2026 Adopted Budget	FY 2026 Total Actual Year-to-Date	VARIANCE Over (Under) to Budget
1 REVENUES			
2 Assessments On-Roll	\$ 421,016	\$ 408,821	\$ (12,196)
3 Assessments Off-Roll	-	-	-
4 Interest & Miscellaneous	-	5,984	5,984
5 Reserve Balance	-	-	-
6 TOTAL REVENUES	421,016	414,804	(6,212)
7 EXPENDITURES			
8 Capital Improvement Plan (CIP) - Future FY	180,000	130,970	(49,030)
9 Contingency	150,000	16,773	(133,227)
10 Capital Reserve Fund Contribution	91,016	32,315	(58,701)
11 TOTAL EXPENDITURES	421,016	180,057	(240,959)
12 REVENUE OVER (UNDER) EXPENDITURES	-	234,747	234,747
13 OTHER FINANCING SOURCES & USES			
14 Transfers In	274,921	-	(274,921)
15 Transfers Out	-	-	-
16 TOTAL OTHER FINANCING SOURCES & USES	274,921	-	(274,921)
17 NET CHANGE IN FUND BALANCE	274,921	234,747	(40,174)
18 Fund Balance - Beginning	157,892	347,249	189,357
19 FUND BALANCE - ENDING - PROJECTED	\$ 432,813	\$ 581,996	\$ 149,183

Beach CDD
Debt Service 2015A
Statement of Revenue, Expenditures, and Changes in Fund Balance
For the period from October 1, 2025 to March 31, 2026

	FY 2026 Adopted Budget	FY 2026 Total Actual Year-to-Date	VARIANCE Over (Under) to Budget
1 REVENUES			
2 Assessments On-Roll	\$ 575,993	\$ 559,308	\$ (16,685)
3 Assessments Off-Roll	-	-	-
4 Interest Revenue	-	5,450	5,450
5 Misc. Revenue	-	19,081	19,081
6 TOTAL REVENUES	575,993	583,839	7,846
7 EXPENDITURES			
8 Interest Expense			
9 *November 1, 2025	198,683	196,618	(2,065)
10 May 1, 2026	198,683	-	(198,683)
11 November 1, 2026	193,373	-	(193,373)
12 Principal Retirement			
13 May 1, 2026	180,000	-	(180,000)
14 Principal Prepayment	-	-	-
15 TOTAL EXPENDITURES	572,055	196,618	375,438
16 REVENUE OVER (UNDER) EXPENDITURES	3,938	387,221	383,284
17 OTHER FINANCING SOURCES & USES			
18 Transfers In	-	-	-
19 Transfers Out	-	-	-
20 TOTAL OTHER FINANCING SOURCES & USES	-	-	-
21 NET CHANGE IN FUND BALANCE	3,938	387,221	383,284
22 Fund Balance - Beginning	-	239,116	239,116
23 FUND BALANCE - ENDING - PROJECTED	\$ 3,938	\$ 626,339	\$ 622,401

* Financed with prior year's revenue

Beach CDD
Debt Service 2024

Statement of Revenue, Expenditures, and Changes in Fund Balance
For the period from October 1, 2025 to March 31, 2026

	FY 2026 Adopted Budget	FY 2026 Total Actual Year-to-Date	VARIANCE Over (Under) to Budget
1 REVENUES			
2 Assessments On-Roll	\$ 659,084	\$ 639,993	\$ (19,092)
3 Assessments Off-Roll	-	-	-
4 Interest Revenue	-	9,106	9,106
5 Misc. Revenue	-	13,569	13,569
6 TOTAL REVENUES	659,084	662,668	3,583
7 EXPENDITURES			
8 Interest Expense			
9 *November 1, 2025	194,534	194,534	-
10 May 1, 2026	194,534	-	(194,534)
11 November 1, 2026	189,550	-	(189,550)
12 Principal Retirement			
13 May 1, 2026	275,000	-	(275,000)
14 Principal Prepayment	-	15,000	15,000
15 TOTAL EXPENDITURES	659,084	209,534	449,550
16 REVENUE OVER (UNDER) EXPENDITURES	-	453,133	453,133
17 OTHER FINANCING SOURCES & USES			
18 Transfers In	-	-	-
19 Transfers Out	-	-	-
20 TOTAL OTHER FINANCING SOURCES & USES	-	-	-
21 NET CHANGE IN FUND BALANCE	-	453,133	453,133
22 Fund Balance - Beginning	-	403,527	403,527
23 FUND BALANCE - ENDING - PROJECTED	\$ -	\$ 856,662	\$ 856,662

* Financed with prior year's revenue

Beach CDD
Valley Check Register - FY2026

Date	Number	Name	Memo	Deposits	Payments	Balance
09/30/2025		Beginning of Year				179,975.46
10/01/2025	167		Southstate Account Verify		0.67	179,974.79
10/01/2025	168		Southstate Account Verify	0.67		179,975.46
10/02/2025	2016	The Jacksonville Party Company	Casino Night - Decor		1,000.00	178,975.46
10/07/2025	400013	The Lake Doctors, Inc.	Invoice: 312328B (Reference: Water Management Oct 25.)		2,369.00	176,606.46
10/07/2025	400014	All Weather Contractors, Inc.	Invoice: 200984 (Reference: Plumbing Service Call.)		255.00	176,351.46
10/07/2025	400015	VGlobal Tech	Invoice: 7759 (Reference: Email Hosting Oct 25.)		90.00	176,261.46
10/07/2025	400016	SchoolNow	Invoice: INV-SN-966 (Reference: Website Hosting.)		1,515.00	174,746.46
10/07/2025	400017	Integrated Access Solutions	Invoice: 4823 (Reference: BAI Barcode Stickers.)		452.36	174,294.10
10/07/2025	400018	Cintas Corporation	Invoice: 9340265618 (Reference: AED AUTOMATIC AGREEMENT.)		154.00	174,140.10
10/07/2025	400019	Custom Pump & Controls, Inc.	Invoice: S1129661 (Reference: Lift Station Inspection.)		300.00	173,840.10
10/07/2025	400021	Vesta District Services	Invoice: 428924 (Reference: Management Fees Oct 25.)		4,409.75	169,430.35
10/07/2025	400022	Advanced Security Specialist & Consulting	Invoice: BCDD100125 (Reference: Guard Services 9/16/25 - 9/30/25.)		10,741.50	158,688.85
10/08/2025	2017	Pawel Szeszko	BOS Workshop 10/2/25		200.00	158,488.85
10/08/2025	2018	Todd Caprita	BOS Workshop 10/2/25		200.00	158,288.85
10/08/2025	2019	Risk Management Associates, Inc.	FY Insurance Policy # PK FL1 0164008 25-01 10/01/25-10/01/26		51,522.00	106,766.85
10/08/2025	2020	Preferred Governmental Insurance Trust	FY Insurance Policy # WC FL1 0164008 10/01/25 - 10/1/26		2,000.00	104,766.85
10/08/2025			Deposit	60.00		104,826.85
10/08/2025	100825ACH1	KS State Bank	Fitness Equipment Financing		1,539.95	103,286.90
10/09/2025			Deposit	56.17		103,343.07
10/14/2025	400023	Integrated Access Solutions	Invoice: 4853 (Reference: Service Call.)		250.00	103,093.07
10/14/2025	400024	Vesta District Services	Invoice: 428972 (Reference: FY?2026 Dissmination Agent Fee.) Invoice: 429041 (Reference: Bill..		2,885.25	100,207.82
10/14/2025	400025	Jacksonville Daily Record	Invoice: 25-06138D (Reference: Legal Advertising.)		100.00	100,107.82
10/14/2025	400026	E.T.M.	Invoice: 222054 (Reference: ENGINEERING SERVICES Aug & Sept 25.)		820.00	99,287.82
10/15/2025	101525ACH1	GFL Environmental	Trash Service		239.65	99,048.17
10/16/2025	2021	Bouncers, Slides, and More Inc.	Inflatable Outdoor Games		1,200.00	97,848.17
10/16/2025	2022	Florida Party Works LLC	Mechanical Bull with Operator		1,000.00	96,848.17
10/16/2025	101625ACH1	JEA	Service for the month of Sept 2025		21,070.57	75,777.60
10/17/2025	101725ACH1	TECO	12545 Beach Blvd - Aug 20, 2025 - Sep 19, 2025		51.13	75,726.47
10/20/2025	102025ACH2	Comcast	12788 Meritace Blvd MINI MDTA Sep 28, 2025 to Oct 27, 2025		733.26	74,993.21
10/20/2025	102025ACH3	Comcast	12750 Meritace Blvd. GATEHOUSE Sep 30, 2025 to Oct 29, 2025		291.02	74,702.19
10/20/2025	102025CC1	US BANK VISA CC	Aug Statement 8/26/25 - 9/24/25		1,417.37	73,284.82
10/20/2025	400027	Vesta Property Services	Invoice: 429062 (Reference: Amenity Management Sept 25.)		33,392.00	39,892.82
10/20/2025			Deposit	50.00		39,942.82
10/20/2025			Deposit	1,550.00		41,492.82
10/20/2025			Deposit	1,400.00		42,892.82
10/21/2025	102125ACH1	Florida Natural Gas	Fuel and Inside FGT Z3 8/18/25 - 9/19/25		12.20	42,880.62
10/21/2025	400028	Integrated Access Solutions	Invoice: 4922 (Reference: Gate Arm Repair.)		526.67	42,353.95
10/21/2025	400029	Lucas Tree Service, Inc.	Invoice: 10241 (Reference: Dead Tree Removal.) Invoice: 10240 (Reference: Dead Tree Removal.)		1,350.00	41,003.95
10/22/2025	2023	Pawel Szeszko	BOS Meeting 10/20/25		200.00	40,803.95
10/22/2025	2024	Todd Caprita	BOS Meeting 10/20/25		200.00	40,603.95
10/23/2025	400030	Lucas Tree Service, Inc.	Invoice: 10239 (Reference: Dead Tree Removal.)		2,000.00	38,603.95
10/23/2025	400031	Hawkins Inc.	Invoice: 7228252 (Reference: Pool Chemicals.)		2,110.00	36,493.95
10/23/2025			Funds Transfer	500,000.00		536,493.95
10/24/2025	400032	D Armstrong Contacting, LLC	Invoice: 13918 (Reference: 18" Storm Pipe Replacement.)		24,280.00	512,213.95
10/24/2025	400033	Big Jerry's Fencing	Invoice: CR 3855e (Reference: Fencing Installation. Check Stub Notes: \$500.00 deposit.)		500.00	511,713.95
10/24/2025	102425ACH1	Turner Pest Control	Pest Control		122.23	511,591.72
10/28/2025	2025	Big Jerry's Fencing	Fencing Installation deposit minus \$500.00 already paid		2,425.00	509,166.72
10/29/2025			Funds Transfer	423,205.83		932,372.55
10/30/2025	2026	Quality Cleaning by Viktoriia LLC	Reference: Cleaning Services Sept 25		1,680.00	930,692.55
10/30/2025	400034	Advanced Security Specialist & Consulting	Invoice: BCDD101525 (Reference: Security 10/1/25 - 10/15/25.)		11,209.00	919,483.55
10/30/2025	400035	TEKWave Solutions LLC	Invoice: 7652 (Reference: VMS - NOV.)		350.00	919,133.55

Date	Number	Name	Memo	Deposits	Payments	Balance
10/30/2025	400036	Big Jerry's Fencing	Invoice: 3810e (Reference: Fence Replacement.)		1,650.00	917,483.55
10/30/2025	400037	Kutak Rock LLP	Invoice: 3642516 (Reference: General Counsel July 25.)		2,030.00	915,453.55
10/30/2025	400038	Ruppert Landscape, LLC	Invoice: 770772 (Reference: Landscape Management Oct 25.)		33,068.80	882,384.75
10/30/2025	400039	Integrated Access Solutions	Invoice: 4977 (Reference: Gate Repair.)		420.00	881,964.75
10/30/2025	103025ACH1	Comcast	13077 Beach Blvd. PEDESTRIAN GATE Oct 10, 2025 to Nov 09, 2025		214.72	881,750.03
10/31/2025	400040	Southeastern Paper Group	Invoice: 06536417 (Reference: Janitorial Supplies.)		221.48	881,528.55
10/31/2025	400041	Quality Cleaning by Viktoriia LLC	Invoice: 857_US (Reference: Cleaning Services Oct 25.)		1,680.00	879,848.55
10/31/2025			Interest	1,063.84		880,912.39
10/31/2025		End of Month		927,386.51	226,449.58	880,912.39
11/03/2025	110325ACH1	KS State Bank	Fitness Equipment Financing		1,539.95	879,372.44
11/03/2025	400042	Jacksonville Daily Record	Invoice: 25-06524D (Reference: Legal Advertising.) Invoice: 25-06615D (Reference: Legal Adver...		406.50	878,965.94
11/04/2025	400043	Cintas Corporation	Invoice: 9344814494 (Reference: AED AUTOMATIC AGREEMENT.)		154.00	878,811.94
11/04/2025	400044	The Lake Doctors, Inc.	Invoice: 320872B (Reference: Water Management Nov 25.)		2,369.00	876,442.94
11/04/2025	400045	VGlobal Tech	Invoice: 7849 (Reference: Email Hosting Nov 25.)		90.00	876,352.94
11/10/2025	2027	Pawel Szeszko	BOS Workshop 11/6/25		200.00	876,152.94
11/10/2025	2028	Todd Caprita	BOS Workshop 11/6/25		200.00	875,952.94
11/12/2025	400046	Vesta District Services	Invoice: 429492 (Reference: Management Fees Nov 25.)		4,409.75	871,543.19
11/12/2025	400047	All Weather Contractors, Inc.	Invoice: 202918 (Reference: Leak repair.)		315.00	871,228.19
11/12/2025	400048	Jacksonville Daily Record	Invoice: 25-06713D (Reference: Legal Advertising.)		100.00	871,128.19
11/12/2025	400049	Dibartolomeo, McBee, Hartley & Barnes, PA	Invoice: 90108294 ()		3,650.00	867,478.19
11/12/2025	400050	Premier Property Services Jax	Invoice: 1879 (Reference: Phase 4 Mowing.)		1,190.00	866,288.19
11/12/2025	400051	Advanced Security Specialist & Consulting	Invoice: BCDD110125 (Reference: Security 10/16/25 - 10/31/25.)		11,363.00	854,925.19
11/12/2025	400052	E.T.M.	Invoice: 222553 (Reference: ENGINEERING SERVICES thru 10/25/25.)		970.00	853,955.19
11/12/2025	400053	C Buss Enterprises, Inc.	Invoice: 4775 (Reference: Water Feature repair.) Invoice: 4776 (Reference: Fountain Repair.)		304.97	853,650.22
11/12/2025	400054	Sundancer Sign Graphics	Invoice: 15632 (Reference: Sign Installation.) Invoice: 15631 (Reference: Sign Installation.)		3,160.00	850,490.22
11/14/2025			Deposit	194,588.63		1,045,078.85
11/17/2025	111725ACH1	GFL Environmental	Trash Service		348.85	1,044,730.00
11/17/2025	111725ACH2	JEA	Service for the month of Oct 2025		21,243.58	1,023,486.42
11/17/2025	111725ACH3	TECO	12545 Beach Blvd - Sep 20, 2025 - Oct 20, 2025		51.85	1,023,434.57
11/17/2025			Deposit	56.17		1,023,490.74
11/17/2025	400055	Bob's Backflow & Plumbing Services	Invoice: 28496 (Reference: Backflow Testing.)		495.00	1,022,995.74
11/17/2025	400056	Integrated Access Solutions	Invoice: 5080 (Reference: Service Call.)		250.00	1,022,745.74
11/17/2025	400057	Screening One	Invoice: SC100395797 (Reference: Employment Screenings.)		38.00	1,022,707.74
11/18/2025	111825ACH1	Comcast	12788 Meritace Blvd MINI MDTA Oct 28, 2025 to Nov 27, 2025		403.77	1,022,303.97
11/20/2025	112025ACH1	Comcast	12750 Meritace Blvd. GATEHOUSE Oct 30, 2025 - Nov 29, 2025		412.86	1,021,891.11
11/20/2025	112025ACH2	Florida Natural Gas	Fuel and Inside FGT Z3 9/19/25 - 10/20/25		12.67	1,021,878.44
11/20/2025	2029	Pawel Szeszko	BOS Meeting 11/17/25		200.00	1,021,678.44
11/20/2025	2030	Todd Caprita	BOS Meeting 11/17/25		200.00	1,021,478.44
11/20/2025	112025CC1	US BANK VISA CC	Oct Statement 9/25/25 - 10/23/25		5,880.98	1,015,597.46
11/20/2025			Deposit	255,597.77		1,271,195.23
11/21/2025	2031	FLORIDA DEPT OF ECONOMIC OPPORTUNIT	FY 2025/2026 Special District Fee Invoice/Update Form		175.00	1,271,020.23
11/21/2025	400058	Blinge of Jacksonville	Invoice: 11013706 (Reference: Installation Light system. Check Stub Notes: \$3,000.00 Deposit.)		3,000.00	1,268,020.23
11/21/2025	400059	Hawkins Inc.	Invoice: 7259184 (Reference: Pool Chemicals.)		1,301.00	1,266,719.23
11/24/2025			Funds Transfer	77,777.69		1,344,496.92
11/24/2025			Funds Transfer	12.00		1,344,508.92
11/26/2025			Funds Transfer	0.29		1,344,509.21
11/26/2025			Deposit	299,960.98		1,644,470.19
11/28/2025	112825ACH1	Turner Pest Control	Pest Control		122.23	1,644,347.96
11/30/2025			Interest	3,532.86		1,647,880.82
11/30/2025		End of Month		831,526.39	64,557.96	1,647,880.82
12/01/2025	120125ACH1	KS State Bank	Fitness Equipment Financing		1,539.95	1,646,340.87
12/01/2025	120125ACH2	Comcast	13077 Beach Blvd. PEDESTRIAN GATE Nov 10, 2025 to Dec 09, 2025		214.72	1,646,126.15
12/02/2025	400060	Integrated Access Solutions	Invoice: 5128 (Reference: Barcode Stickers.)		452.36	1,645,673.79
12/02/2025	400061	Vesta District Services	Invoice: 429431 (Reference: Billable Expenses - Oct 2025.)		42.61	1,645,631.18
12/02/2025	400062	Jacksonville Daily Record	Invoice: 25-06877D (Reference: Legal Advertising.)		96.50	1,645,534.68

Date	Number	Name	Memo	Deposits	Payments	Balance
12/02/2025	400063	Kutak Rock LLP	Invoice: 3657435 (Reference: General Counsel Aug 25.)		5,442.58	1,640,092.10
12/03/2025	400064	Vesta Property Services	Invoice: 429456 (Reference: Amenity Management.)		31,607.70	1,608,484.40
12/03/2025	400065	Ruppert Landscape, LLC	Invoice: 780488 (Reference: Landscape Management Nov 25.)		33,068.80	1,575,415.60
12/03/2025	400066	Jacksonville Daily Record	Invoice: 25-07088D (Reference: Legal Advertising.)		205.00	1,575,210.60
12/03/2025	400067	Southeastern Paper Group	Invoice: 06564869 (Reference: Janitorial Supplies.)		389.99	1,574,820.61
12/03/2025	400068	Cintas Corporation	Invoice: 9348787802 (Reference: AED AUTOMATIC AGREEMENT.)		154.00	1,574,666.61
12/04/2025	400069	The Lake Doctors, Inc.	Invoice: 328682B (Reference: Water Management Dec 25.)		2,369.00	1,572,297.61
12/04/2025	400070	VGlobal Tech	Invoice: 7935 (Reference: Email Hosting.)		90.00	1,572,207.61
12/04/2025	400071	Blingle of Jacksonville	Invoice: 11101003 (Reference: Holiday Lighting.)		5,355.00	1,566,852.61
12/04/2025	400072	Bob's Backflow & Plumbing Services	Invoice: 28828 (Reference: Backflow Testing.) Invoice: 28829 (Reference: Backflow Repairs.)		195.00	1,566,657.61
12/04/2025	400073	Sundancer Sign Graphics	Invoice: 15662 (Reference: Fitness Center Sign.)		345.00	1,566,312.61
12/04/2025			Deposit	2,351,941.85		3,918,254.46
12/05/2025	400074	Advanced Security Specialist & Consulting	Invoice: BCDD111525 (Reference: Security Monitoring 11/1/25 - 11/15/25.) Invoice: BCDD120125 ...		23,309.00	3,894,945.46
12/05/2025	400075	E.T.M.	Invoice: 223068 (Reference: Engineering Services thru Nov 22, 2025.)		127.50	3,894,817.96
12/05/2025	400076	TEKWave Solutions LLC	Invoice: 7702 (Reference: Website Hosting Dec 25.)		350.00	3,894,467.96
12/09/2025	2032	BNY Mellon Payment/Trustee Fees	Trustee Fees 2025 Series 15A Nov 1, 2025 - Oct 31, 2026		4,400.00	3,890,067.96
12/10/2025	2033	Shannon Brooke Thomas	Reference: Christmas Ornaments 12/13/25.		500.00	3,889,567.96
12/10/2025			Deposit	334,573.14		4,224,141.10
12/12/2025	400077	Integrated Access Solutions	Invoice: 4743 (Reference: Service Call.) Invoice: 4993 (Reference: Service Call on Gate.)		2,434.89	4,221,706.21
12/12/2025	400078	Jacksonville Daily Record	Invoice: 25-07148D (Reference: Legal Advertising.) Invoice: 25-07149D (Reference: Legal Adver...		207.00	4,221,499.21
12/12/2025	400079	Wayne Automatic Fire Sprinklers Inc.	Invoice: 1254584 (Reference: Annual Sprinkler Inspection.)		300.00	4,221,199.21
12/12/2025	400080	Buehler Air Conditioning	Invoice: 252699 (Reference: Maintenance & Repairs.)		734.00	4,220,465.21
12/15/2025	121525ACH1	JEA	Service for the month of Nov 2025		14,856.26	4,205,608.95
12/15/2025	400081	Vesta Property Services	Invoice: 429851 (Reference: Amenity Management.)		31,502.52	4,174,106.43
12/16/2025	2034	Pawel Szeszko	BOS Workshop 12/4/25		200.00	4,173,906.43
12/16/2025	2035	Todd Caprita	BOS Workshop 12/4/25		200.00	4,173,706.43
12/16/2025	2036	Pawel Szeszko	BOS Meeting 12/15/25		200.00	4,173,506.43
12/16/2025	2037	Todd Caprita	BOS Meeting 12/15/25		200.00	4,173,306.43
12/16/2025			Deposit	56.17		4,173,362.60
12/16/2025	121625ACH1	GFL Environmental	Trash Service		204.75	4,173,157.85
12/17/2025	121725ACH1	TECO	12545 Beach Blvd - Oct 21, 2025 - Nov 19, 2025		51.13	4,173,106.72
12/17/2025			Deposit	16,203.90		4,189,310.62
12/18/2025	121825ACH1	Comcast	12788 Meritace Blvd MINI MDTA Nov 28, 2025 to Dec 27, 2025		454.16	4,188,856.46
12/19/2025	2039	Reynaldo Espino Jr.	Refund for outdoor space not used		200.00	4,188,656.46
12/22/2025	400082	Quality Cleaning by Viktoriia LLC	Invoice: 623_US (Reference: Cleaning Services Aug 25.)		2,184.00	4,186,472.46
12/22/2025	400083	Vesta District Services	Invoice: 429980 (Reference: Management Fees Dec 25.)		4,409.75	4,182,062.71
12/22/2025	400084	Jacksonville Daily Record	Invoice: 25-07379D (Reference: Legal Advertising.)		268.00	4,181,794.71
12/22/2025	122225ACH1	Comcast	12750 Meritace Blvd. GATEHOUSE Nov 30, 2025 - Dec 29, 2025		419.13	4,181,375.58
12/22/2025	122225ACH3	Florida Natural Gas	Fuel and Inside FGT Z3 10/20/25 - 11/19/25		12.20	4,181,363.38
12/22/2025	122225ACH2	US BANK VISA CC	Nov Statement 10/24/25 - 11/24/25		5,169.86	4,176,193.52
12/23/2025	2040	Baer's Furniture Co., Inc.	Furniture & Tables		40,732.00	4,135,461.52
12/26/2025	400085	TEKWave Solutions LLC	Invoice: 7771 (Reference: VMS Jan.)		350.00	4,135,111.52
12/26/2025	400086	Big Jerry's Fencing	Invoice: CR 3855e2 (Reference: Fence Repair.)		2,925.00	4,132,186.52
12/29/2025	400087	Ramco Protective	Invoice: 73190 (Reference: Security Officer 12/22/25 - 1/31/26.)		25,585.40	4,106,601.12
12/30/2025	2041	BNY Mellon Tax Distributions			1,143,097.41	2,963,503.71
12/30/2025	400088	Quality Cleaning by Viktoriia LLC	Invoice: 926 (Reference: Cleaning Services Nov 25.)		1,680.00	2,961,823.71
12/30/2025	400089	Ruppert Landscape, LLC	Invoice: 791471 (Reference: Landscape Management Dec 25.)		33,068.80	2,928,754.91
12/30/2025	400090	Jacksonville Daily Record	Invoice: 25-07668D (Reference: Legal Advertising.)		96.50	2,928,658.41
12/30/2025	123025ACH1	Comcast	13077 Beach Blvd. PEDESTRIAN GATE Dec 10, 2025 to Jan 9, 2026		222.95	2,928,435.46
12/31/2025			Interest	12,548.00		2,940,983.46
12/31/2025		End of Month		2,715,323.06	1,422,220.42	2,940,983.46
01/02/2026	010226ACH1	KS State Bank	Fitness Equipment Financing		1,539.95	2,939,443.51
01/05/2026	400091	US Water Services Corporation	Invoice: S1136263 (Reference: Lift Station Inspection.)		300.00	2,939,143.51
01/05/2026	400092	The Lake Doctors, Inc.	Invoice: 336368B (Reference: Water Management Jan 26.)		2,369.00	2,936,774.51
01/05/2026	400093	Bumble Bee Blinds of Ponte Vedra Beach	Invoice: 2484555 (Reference: Roller Shades.)		4,999.00	2,931,775.51

Date	Number	Name	Memo	Deposits	Payments	Balance
01/05/2026	010526ACH1	Turner Pest Control	Pest Control		122.23	2,931,653.28
01/07/2026	2042	Shannon Brooke Thomas	Christmas Ornaments 12/13/25.		460.00	2,931,193.28
01/07/2026	400094	Cintas Corporation	Invoice: 9353376500 (Reference: AED AUTOMATIC AGREEMENT.)		154.00	2,931,039.28
01/07/2026	400095	Advanced Security Specialist & Consulting	Invoice: BCDDFINAL (Reference: Guard Services 12/1/25 - 12/23/25.)		16,566.00	2,914,473.28
01/07/2026	400096	Jacksonville Daily Record	Invoice: 26-00040D (Reference: Legal Advertising.)		100.00	2,914,373.28
01/07/2026	400097	Southeastern Paper Group	Invoice: 06590804 (Reference: Janitorial Supplies.)		386.52	2,913,986.76
01/07/2026	400098	VGlobal Tech	Invoice: 8072 (Reference: Email Hosting.)		90.00	2,913,896.76
01/09/2026	400099	Vesta District Services	Invoice: 430296 (Reference: Management Fees Jan 26.)		4,409.75	2,909,487.01
01/12/2026	400100	Vesta Property Services	Invoice: 430470 (Reference: Amenity Management Dec 25.)		34,917.82	2,874,569.19
01/12/2026			Deposit	72,869.26		2,947,438.45
01/13/2026	011326ACH1	JEA	Service for the month of Dec 2025		11,969.19	2,935,469.26
01/14/2026	011426ACH1	GFL Environmental	Trash Service		204.75	2,935,264.51
01/15/2026			Deposit	56.17		2,935,320.68
01/20/2026	2043	Pawel Szeszko	BOS Workshop 1/08/26		200.00	2,935,120.68
01/20/2026	2044	Todd Caprita	BOS Workshop 1/08/26		200.00	2,934,920.68
01/20/2026	2045	Pawel Szeszko	BOS Meeting 1/12/26		200.00	2,934,720.68
01/20/2026	2046	Todd Caprita	BOS Meeting 1/12/26		200.00	2,934,520.68
01/20/2026	400101	Screening One	Invoice: SC100399958 (Reference: Employment Screening.)		39.90	2,934,480.78
01/20/2026	400102	Wayne Automatic Fire Sprinklers Inc.	Invoice: 1278080 (Reference: Alarm Monitoring.)		750.00	2,933,730.78
01/20/2026	400103	Integrated Access Solutions	Invoice: 5347 (Reference: BAI Barcode Stickers.)		372.64	2,933,358.14
01/20/2026	400104	Sundancer Sign Graphics	Invoice: 15715 (Reference: Sign Installation.)		260.00	2,933,098.14
01/20/2026	400105	E.T.M.	Invoice: 223658 (Reference: Engineering Services Dec 25.)		99.50	2,932,998.64
01/20/2026	400106	Vesta District Services	Invoice: 430372 (Reference: Billable Expenses - Dec 2025.)		28.90	2,932,969.74
01/20/2026	400107	Hawkins Inc.	Invoice: 7300664 (Reference: Pool Chemicals.)		1,305.00	2,931,664.74
01/20/2026	012026CC1	US BANK VISA CC	Nov Statement 11/24/25 - 12/24/25		4,296.48	2,927,368.25
01/20/2026	012026ACH1	Comcast	12750 Meritage Blvd. GATEHOUSE Dec 30, 2025 - Jan 29, 2025		419.13	2,926,949.12
01/20/2026	012026ACH2	Comcast	12788 Meritace Blvd MINI MDTA Dec 28, 2025 to Jan 27, 2025		454.16	2,926,494.96
01/21/2026	012126ACH1	TECO	12545 Beach Blvd - Nov 20, 2025 - Dec 18, 2025		50.88	2,926,444.08
01/21/2026	012126ACH2	Turner Pest Control	Pest Control		127.18	2,926,316.90
01/21/2026			Deposit	20,906.98		2,947,223.88
01/23/2026			Deposit	920.35		2,948,144.23
01/23/2026	012326ACH1	Florida Natural Gas	Fuel and Inside FGT Z3 11/19/25 - 12/18/25		14.44	2,948,129.79
01/27/2026	400108	Vesta District Services	Invoice: 429877 (Reference: Billable Expenses - Nov 2025.)		13.61	2,948,116.18
01/27/2026	400109	Beaches Electrical Service, Inc.	Invoice: 15768 (Reference: Light Installation.)		497.50	2,947,618.68
01/27/2026	400110	TEKWave Solutions LLC	Invoice: 7873 (Reference: VMS - Feb 26.) Invoice: 7834 (Reference: Installation of Barcode Sc...		2,000.00	2,945,618.68
01/29/2026			Deposit	207.00		2,945,825.68
01/30/2026	013026ACH1	Comcast	13077 Beach Blvd. PEDESTRIAN GATE Jan 10, 2026 to Feb 09, 2026		222.95	2,945,602.73
01/31/2026			Interest	9,507.91		2,955,110.64
01/31/2026		End of Month		104,467.67	90,340.49	2,955,110.64
02/02/2026	020226ACH1	KS State Bank	Fitness Equipment Financing		1,539.95	2,953,570.69
02/02/2026	2047	Bouncers, Slides, and More Inc.	Inflatable Outdoor Games for Easter Event		1,075.00	2,952,495.69
02/02/2026	2048	Kaylie Fitzhugh	Reimbursement for Santa Suit		66.21	2,952,429.48
02/02/2026	2049	Oliver Ingram	Reimbursement Happy Hour New Year Event		40.82	2,952,388.66
02/04/2026	400111	The Lake Doctors, Inc.	Invoice: 344119B (Reference: Water Management Feb 26.)		2,369.00	2,950,019.66
02/04/2026	400112	Jacksonville Daily Record	Invoice: 26-00596 (Reference: Legal Advertising.)		100.00	2,949,919.66
02/04/2026	400113	VGlobal Tech	Invoice: 8152 (Reference: Email Hosting Feb 26.)		90.00	2,949,829.66
02/04/2026	400114	Vesta District Services	Invoice: 430641 (Reference: Management Fees Feb 26.)		4,409.75	2,945,419.91
02/04/2026	400115	Cintas Corporation	Invoice: 9357594656 (Reference: AED AUTOMATIC AGREEMENT.)		154.00	2,945,265.91
02/04/2026			Deposit	37,438.93		2,982,704.84
02/06/2026	2050	Alexis Weber	Face Painting Easter 3/28/26		1,050.00	2,981,654.84
02/09/2026	2061	The Greenery of North Florida, Inc.	50% Deposit		737.18	2,980,917.66
02/10/2026	2051	Pawel Szeszko	BOS Workshop 2/05/26		200.00	2,980,717.66
02/10/2026	2052	Todd Caprita	BOS Workshop 2/05/26		200.00	2,980,517.66
02/10/2026	021026ACH1	Turner Pest Control	Pest Control		127.18	2,980,390.48
02/10/2026	400116	Quality Cleaning by Viktoriia LLC	Invoice: 144 (Reference: Cleaning Services Jan 26.) Invoice: 148_US (Reference: Guard House C...		1,995.00	2,978,395.48

Date	Number	Name	Memo	Deposits	Payments	Balance
02/10/2026	400117	Vesta Property Services	Invoice: 430876 (Reference: Amenity Management Jan 26.)		33,596.16	2,944,799.32
02/10/2026	400118	Ramco Protective	Invoice: 74074 (Reference: Guard Services 2/1/26 - 2/28/26.)		17,048.64	2,927,750.68
02/11/2026	2053	Baer's Furniture Co., Inc.			20,716.00	2,907,034.68
02/17/2026	2054	Pawel Szeszko	BOS Meeting 2/9/26		200.00	2,906,834.68
02/17/2026	2055	Todd Caprita	BOS Meeting 2/9/26		200.00	2,906,634.68
02/17/2026	021726ACH2	GFL Environmental	Trash Service		204.75	2,906,429.93
02/17/2026	021726ACH1	Comcast	12788 Meritace Blvd MINI MDTA Jan 28, 2026 to Feb 27, 2026		453.94	2,905,975.99
02/17/2026	2056	Jacksonville Daily Record	Misapplied Credit Ck #400078 for inv25-07148D & 25-07149D		207.00	2,905,768.99
02/18/2026	2057	The Greenery of North Florida, Inc.	50% Deposit River Rock		13,471.55	2,892,297.44
02/18/2026	400119	Vesta District Services	Invoice: 430878 (Reference: Billable Expenses - Jan 2026.)		571.86	2,891,725.58
02/18/2026	400120	Southeastern Paper Group	Invoice: 06628895 (Reference: Janitorial Supplies.)		258.19	2,891,467.39
02/18/2026	400121	Screening One	Invoice: SC100401895 (Reference: Employment Screenings.)		1.90	2,891,465.49
02/18/2026	400122	Wayne Automatic Fire Sprinklers Inc.	Invoice: 1276469 (Reference: Quarterly Sprinkler Inspection.)		75.00	2,891,390.49
02/19/2026	400123	Leisure Creations	Invoice: 00104434 (Reference: Replacement Seat Sling.)		511.60	2,890,878.89
02/19/2026	400124	360 Painting of Jacksonville	Invoice: 32444934 (Reference: Painting.)		2,056.47	2,888,822.42
02/19/2026	400125	Hawkins Inc.	Invoice: 7326745-1 (Reference: Pool Chemicals.)		1,319.50	2,887,502.92
02/19/2026	021926ACH1	TECO	12545 Beach Blvd - Dec 19, 2025 - Jan 22, 2026		73.50	2,887,429.42
02/19/2026	021926ACH2	JEA	Service for the month of Jan 2026		15,689.81	2,871,739.61
02/19/2026	021926ACH3	Comcast	12750 Meritage Blvd. GATEHOUSE Jan 30, 2026 - Feb 28, 2026		418.99	2,871,320.62
02/20/2026	022026CC1	US BANK VISA CC	Jan Statement 12/24/25 - 01/23/26		3,375.23	2,867,945.39
02/20/2026			Deposit	56.17		2,868,001.56
02/20/2026			Deposit	13,968.85		2,881,970.41
02/24/2026	400126	Blingle of Jacksonville	Invoice: 11013706-1 (Reference: Installation of Permanent Lighting System.)		3,000.00	2,878,970.41
02/24/2026	022426ACH1	Florida Natural Gas	Fuel and Inside FGT Z3 12/18/25 - 1/22/26		15.08	2,878,955.33
02/24/2026	022426EFT	Florida Dept. of Revenue	January 2026 Sales Tax		637.75	2,878,317.58
02/27/2026	2059	LLS Tax Solutions, Inc.	Arbitrage Services Series 2024		650.00	2,877,667.58
02/28/2026			Interest	7,925.71		2,885,593.29
02/28/2026		End of Month		59,389.66	128,907.01	2,885,593.29
03/02/2026	030226ACH1	Comcast	13077 Beach Blvd. PEDESTRIAN GATE Feb 10, 2026 to Mar 09, 2026		222.95	2,885,370.34
03/02/2026	030226ACH2	KS State Bank	Fitness Equipment Financing		1,539.95	2,883,830.39
03/02/2026			Deposit	66.50		2,883,896.89
03/02/2026	400127	Vesta District Services	Invoice: 431088 (Reference: Management Fees March 26.)		4,409.75	2,879,487.14
03/02/2026	400128	Clear Impressions Inc.	Invoice: 18494 (Reference: Installation of Ultra View 5.)		3,520.00	2,875,967.14
03/02/2026	400129	360 Painting of Jacksonville	Invoice: 32809561 (Reference: Painting.)		2,993.90	2,872,973.24
03/02/2026	400130	Kutak Rock LLP	Invoice: 3703053 (Reference: Legal Services Nov 25.)		3,117.00	2,869,856.24
03/02/2026	400131	The Lake Doctors, Inc.	Invoice: 351939B (Reference: Water Management March 26.)		2,369.00	2,867,487.24
03/02/2026	400132	Jacksonville Daily Record	Invoice: 26-01108D ()		96.50	2,867,390.74
03/02/2026	400133	TEKWave Solutions LLC	Invoice: 7931 (Reference: VMS - MAR 26.)		350.00	2,867,040.74
03/04/2026	2060	Bouncers, Slides, and More Inc.	Teen Event 3/13/26		1,300.00	2,865,740.74
03/04/2026			Deposit	8,110.23		2,873,850.97
03/05/2026	400134	Cintas Corporation	Invoice: 9361655849 (Reference: AED AUTOMATIC AGREEMENT.)		154.00	2,873,696.97
03/05/2026	400135	VGlobal Tech	Invoice: 8234 (Reference: Email hosting Mar 26.)		90.00	2,873,606.97
03/05/2026	400136	Just Call Ollie LLC	Invoice: INV-250693 (Reference: Drapery Rod Installation.)		500.00	2,873,106.97
03/05/2026	400137	Quality Cleaning by Viktoriia LLC	Invoice: 285_US (Reference: Cleaning Services March 26.)		1,680.00	2,871,426.97
03/09/2026	2062	Manmohan Singh Dhanjal	Rental Reservation Refund		850.00	2,870,576.97
03/09/2026	2063	Pawel Szeszko	BOS Workshop 3/05/26		200.00	2,870,376.97
03/09/2026	2064	Todd Caprita	BOS Workshop 3/05/26		200.00	2,870,176.97
03/09/2026	400138	Jacksonville Daily Record	Invoice: 26-01256D (Reference: News Paper ad.)		100.00	2,870,076.97
03/09/2026	400139	Buehler Air Conditioning	Invoice: 261023 (Reference: A/C Service.)		1,794.00	2,868,282.97
03/09/2026	400140	Vesta Property Services	Invoice: 431393 (Reference: Amenity Management Feb 26.)		33,707.66	2,834,575.31
03/11/2026	031126ACH1	Turner Pest Control	Pest Control		127.18	2,834,448.13
03/12/2026	EFT031226	Florida Dept. of Revenue	December 2025 Sales Tax		407.31	2,834,040.82
03/16/2026			Deposit	56.17		2,834,096.99
03/17/2026	400141	Wayne Automatic Fire Sprinklers Inc.	Invoice: 1295513 (Reference: Fire Extinguisher Inspection.)		153.00	2,833,943.99
03/17/2026	400142	Integrated Access Solutions	Invoice: 5602 (Reference: Service Call.)		250.00	2,833,693.99

Date	Number	Name	Memo	Deposits	Payments	Balance
03/17/2026	400143	Hawkins Inc.	Invoice: 7354977 (Reference: Pool Chemicals.)		1,776.29	2,831,917.70
03/17/2026	400144	Jacksonville Daily Record	Invoice: 26-00597D (Reference: Legal Advertising.)		96.50	2,831,821.20
03/17/2026	400145	Southeastern Paper Group	Invoice: 06649571 (Reference: Janitorial Supplies.)		305.12	2,831,516.08
03/17/2026	031726ACH1	Comcast	12788 Meritace Blvd MINI MDTA Feb 28, 2026 to Mar 27, 2026		453.94	2,831,062.14
03/18/2026	2066	Lidiya Savitskiy	Rental Refund		1,550.00	2,829,512.14
03/18/2026	400146	Integrated Access Solutions	Invoice: 5627 (Reference: Barcode Stickers.)		452.36	2,829,059.78
03/18/2026	400147	First Coast Mulch	Invoice: 4596 (Reference: Installation of Playground Mulch.)		2,220.00	2,826,839.78
03/18/2026	031826ACH1	GFL Environmental	Trash Service		204.75	2,826,635.03
03/18/2026			Deposit	20,220.32		2,846,855.35
03/19/2026	031926ACH1	JEA	Service for the month of Feb 2026		12,685.89	2,834,169.46
03/19/2026	EFT031926	Florida Dept. of Revenue	February 2026 Sales Tax		502.49	2,833,666.97
03/19/2026	031926ACH2	Comcast	12750 Meritage Blvd. GATEHOUSE Mar 01, 2026 to Mar 29, 2026		418.99	2,833,247.98
03/20/2026	032026ACH2	TECO	12545 Beach Blvd - Jan 23, 2026 - Feb 20, 2026		72.81	2,833,175.17
03/20/2026	032026ACH1	US BANK VISA CC	Feb Statement 01/24/25 - 02/23/26		2,659.92	2,830,515.25
03/24/2026	2067	Pawel Szeszko	BOS Meeting 3/16/26		200.00	2,830,315.25
03/24/2026	2068	Todd Caprita	BOS Meeting 3/16/26		200.00	2,830,115.25
03/24/2026	032426ACH1	Florida Natural Gas	Fuel and Inside FGT Z3 1/22/26 - 2/20/26		17.13	2,830,098.12
03/27/2026	400148	Wayne Automatic Fire Sprinklers Inc.	Invoice: 1298880 (Reference: Semi Annual Sprinkler Inspection.)		150.00	2,829,948.12
03/27/2026	400149	The Lake Doctors, Inc.	Invoice: 2210419 (Reference: Fountain Service Call.)		200.00	2,829,748.12
03/27/2026	400150	Life Fitness	Invoice: 8248607 (Reference: Pad & Roller Pad.)		317.30	2,829,430.82
03/27/2026	400151	Integrated Access Solutions	Invoice: 5680 (Reference: Gate Repair.)		675.00	2,828,755.82
03/27/2026	400152	Southeast Fitness	Invoice: 2604 (Reference: Fitness Equipment Inspection.)		756.00	2,827,999.82
03/30/2026	033026ACH1	Comcast	13077 Beach Blvd. PEDESTRIAN GATE Mar 10, 2026 to Apr 9, 2026		222.95	2,827,776.87
03/30/2026	400153	Ruppert Landscape, LLC	Invoice: 801051 (Reference: Landscape Management Jan 26.)		33,068.80	2,794,708.07
03/31/2026			Interest	8,513.28		2,803,221.35
03/31/2026		End of Month		36,966.50	119,338.44	2,803,221.35

Beach CDD
Other Financing Sources Income
March 31, 2026

Other Financing Sources Breakdown

	Year To Date Actual	Explanation
Room Rentals	21,577	Clubhouse, Cabana, Hall and Table & Chairs Rentals
Event Sponsorship & Entry Fees	1,383	Sponsorship, Newsletter & Casino Night & Event
Access Cards	1,598	Access Cards Purchased & Sold by District
Barcode Decals	2,800	Barcodes Sold
Other Misc.	353	Clover Fees & OFFI Island Wing Deposits
	\$ 27,712	

Oliver's Receipts

February 2026

Trivia Night



BJ'S WHOLESALE CLUB ONLINE ORDER RECEIPT

MEMBER NAME: Oliver Ingram

MEMBERSHIP ID: *****6285

PHONE NUMBER: 9045366367 **DATE:** 01/23/202601:10 PM

ORDER #: 281317901

MEMBER VEHICLE: Sedan Gray 3

ITEM #	UPC	DESCRIPTION	QTY	PRICE	PROMOS & COUPONS
52430	052000045956	PROPEL FITNESS WATER VARIETY PACK, 24 PK./16.9 OZ.	1 of 1	\$15.49	
12173	715756100033	RASPBERRIES, 12 OZ.	2 of 2	\$10.98	
14153	400000141534	BLUEBERRIES, 18 OZ.	2 of 2	\$10.98	
18004	027918045831	SLEEVED CELERY STALK	1 of 1	\$1.99	
18331	812049007359	BLACKBERRIES, 12 OZ.	2 of 2	\$8.98	
187126	888670068090	WELLSLEY FARMS ENGLISH SEEDLESS CUCUMBERS, 2 CT.	1 of 1	\$1.99	
28833	052000048179	GATORADE THIRST QUENCHER VARIETY, 28 PK./12 FL. OZ.	1 of 1	\$16.29	
32207	057836021174	WILD WONDERS GOURMET MEDLEY TOMATOES, 1.5 LBS.	1 of 1	\$5.99	
328642	888670183014	WELLSLEY FARMS MAC AND CHEESE BITES, 3 CT.	2 of 2	\$21.98	
328646	888670183052	WELLSLEY FARMS STEAK & CHEESE SPRING ROLLS, 24 CT.	3 of 3	\$50.97	
328648	888670183076	WELLSLEY FARMS MINI BEEF EMPANADAS, 24 CT.	3 of 3	\$32.97	
97262	888670053270	WELLSLEY FARMS MIXED PEPPERS, 4 CT.	1 of 1	\$4.49	
981074	201074000000	WELLSLEY FARMS CHOCOLATE CHUNK COOKIES, 37 OZ.	3 of 3	\$29.97	

TOTAL QTY OF ITEMS: 23

PAYMENT METHOD

VISA
**** *1058

ORDER SUMMARY

PICKUP FEE**	\$0.00
ITEM TOTAL	\$217.06
PROMOTIONS & COUPONS	-\$3.99
TOTAL	\$213.07

**The pickup fee covers the cost of handling and preparing orders for members.

BJ'S REFUND POLICY:

All merchandise can be refunded or exchanged except as noted below. See BJ's.com/Return Policy for more detail.

If your return is regarding an electronic item, such as a TV or laptop, we recommend calling our free Tech Advisors service at 877-TECH888 (877-832-4888) prior to returning because many issues can be resolved over the phone.



Final Details for Order #111-1829107-6409038

Order Placed: January 22, 2026
Amazon.com order number: 111-1829107-6409038
Order Total: \$99.99

Business order information
Location: DSD - Tamaya GL code: 53206 Special Events Cost Billable / Non-Billable: Non-Billable Cost center: Northeast

Shipped on January 23, 2026	
Items Ordered	Price
1 of: TOWOND Projector Screen and Stand, 150 inch Indoor Outdoor Projection Screen, Portable 16:9 4K HD Rear Front Movie Scree n with Carry Bag Wrinkle-Free Design for Home Theater Backyard Cinema Sold by: JLFOfficial (seller profile) Condition: New	\$99.99
Shipping Address: Oliver Ingram 12788 MERITAGE BLVD JACKSONVILLE, FL 32246-0705 United States	Item(s) Subtotal: \$99.99 Shipping & Handling: \$0.00 ----- Total before tax: \$99.99 Sales Tax: \$0.00 -----
Shipping Speed: FREE Prime Delivery	Total for This Shipment: \$99.99 -----

Payment information	
Payment Method: Visa Last digits: 1058	Item(s) Subtotal: \$99.99 Shipping & Handling: \$0.00 -----
Billing address Oliver Ingram 12788 MERITAGE BLVD JACKSONVILLE, FL 32246-0705 United States	Total before tax: \$99.99 Estimated Tax: \$0.00 ----- Grand Total: \$99.99
Credit Card transactions	Visa ending in 1058: January 23, 2026: \$99.99

To view the status of your order, return to [Order Summary](#) .



Final Details for Order #111-7085658-0342638

Order Placed: January 22, 2026
Amazon.com order number: 111-7085658-0342638
Order Total: \$29.95

Business order information
Location: DSD - Tamaya GL code: 53206 Special Events Cost Billable / Non-Billable: Non-Billable Cost center: Northeast

Shipped on January 23, 2026	
Items Ordered	Price
1 of: <i>Movie Theater Style 12-Count Popcorn Packs - Pre-Measured 8-Ounce All-in-One Kernel, Salt, Oil Packets for Popping Machines by Great Northern Popcorn</i>	\$29.95
Sold by: Amazon (seller profile) Business Price Condition: New	
Shipping Address: Oliver Ingram 12788 MERITAGE BLVD JACKSONVILLE, FL 32246-0705 United States	Item(s) Subtotal: \$29.95 Shipping & Handling: \$2.99 Free Shipping: -\$2.99 ----- Total before tax: \$29.95 Sales Tax: \$0.00 -----
Shipping Speed: Rush Shipping	Total for This Shipment: \$29.95 -----

Payment information	
Payment Method: Visa Last digits: 1058	Item(s) Subtotal: \$29.95 Shipping & Handling: \$2.99 Promotion applied: -\$2.99 -----
Billing address Oliver Ingram 12788 MERITAGE BLVD JACKSONVILLE, FL 32246-0705 United States	Total before tax: \$29.95 Estimated Tax: \$0.00 -----
	Grand Total: \$29.95
Credit Card transactions	Visa ending in 1058: January 23, 2026: \$29.95

To view the status of your order, return to [Order Summary](#) .



Final Details for Order #111-4266850-4321827

Order Placed: January 22, 2026
Amazon.com order number: 111-4266850-4321827
Order Total: \$16.50

Business order information
Location: DSD - Tamaya GL code: 53206 Special Events Cost Billable / Non-Billable: Non-Billable Cost center: Northeast

Shipped on January 23, 2026	
Items Ordered	Price
1 of: <i>Sugar In The Raw Turbinado Cane Sugar Packets, 200 Ct Box, 1 Pack, Pure, All-Natural Turbinado Sugar, Non-GMO Project Ve rified, Kosher, Vegan and Gluten Free</i> Sold by: Amazon (seller profile) Business Price Condition: New	\$16.50
Shipping Address: Oliver Ingram 12788 MERITAGE BLVD JACKSONVILLE, FL 32246-0705 United States	Item(s) Subtotal: \$16.50 Shipping & Handling: \$0.00 ----- Total before tax: \$16.50 Sales Tax: \$0.00 -----
Shipping Speed: FREE Prime Delivery	Total for This Shipment: \$16.50 -----

Payment information	
Payment Method: Visa Last digits: 1058	Item(s) Subtotal: \$16.50 Shipping & Handling: \$0.00 -----
Billing address Oliver Ingram 12788 MERITAGE BLVD JACKSONVILLE, FL 32246-0705 United States	Total before tax: \$16.50 Estimated Tax: \$0.00 ----- Grand Total: \$16.50
Credit Card transactions	Visa ending in 1058: January 23, 2026: \$16.50

To view the status of your order, return to [Order Summary](#) .



Final Details for Order #111-5822435-6250666

Order Placed: January 22, 2026
Amazon.com order number: 111-5822435-6250666
Order Total: \$119.96

Business order information
Location: DSD - Tamaya GL code: 53206 Special Events Cost Billable / Non-Billable: Non-Billable Cost center: Northeast

Shipped on January 27, 2026	
Items Ordered	Price
4 of: 300pcs Bulk Easter Eggs with Toys Inside Easter Eggs Fillers Plastic Eggs for Easter Egg Hunt 100 Pack Easter Basket Stuffers Fillers Easter Gifts Easter Party Favors for Kids Toddlers Boys Girls <small>Sold by: GDWODE (seller profile) Condition: New</small>	\$29.99
Shipping Address: Oliver Ingram 12788 MERITAGE BLVD JACKSONVILLE, FL 32246-0705 United States	Item(s) Subtotal: \$119.96 Shipping & Handling: \$0.00 ----- Total before tax: \$119.96 Sales Tax: \$0.00 -----
Shipping Speed: FREE Prime Delivery	Total for This Shipment: \$119.96 -----

Payment information	
Payment Method: Visa Last digits: 1058	Item(s) Subtotal: \$119.96 Shipping & Handling: \$0.00 -----
Billing address Oliver Ingram 12788 MERITAGE BLVD JACKSONVILLE, FL 32246-0705 United States	Total before tax: \$119.96 Estimated Tax: \$0.00 ----- Grand Total: \$119.96
Credit Card transactions	Visa ending in 1058: January 28, 2026: \$119.96

To view the status of your order, return to [Order Summary](#) .



Final Details for Order #111-9234076-9414645

Order Placed: January 25, 2026
Amazon.com order number: 111-9234076-9414645
Order Total: \$79.99

Business order information
Location: DSD - Tamaya GL code: 61504 Office Supplies Billable / Non-Billable: Non-Billable Cost center: Northeast

Shipped on January 27, 2026	
Items Ordered	Price
1 of: <i>Amazon Basics 24 Inch (23.8 inch viewable) Monitor, FHD 1080P, Max 100Hz, VESA Compatible, Built-in Speakers, Black</i> Sold by: Amazon.com Condition: New	\$79.99
Shipping Address: Oliver Ingram 12788 MERITAGE BLVD JACKSONVILLE, FL 32246-0705 United States	Item(s) Subtotal: \$79.99 Shipping & Handling: \$0.00 ----- Total before tax: \$79.99 Sales Tax: \$0.00 -----
Shipping Speed: FREE Prime Delivery	Total for This Shipment: \$79.99 -----

Payment information	
Payment Method: Visa Last digits: 1058	Item(s) Subtotal: \$79.99 Shipping & Handling: \$0.00 -----
Billing address Oliver Ingram 12788 MERITAGE BLVD JACKSONVILLE, FL 32246-0705 United States	Total before tax: \$79.99 Estimated Tax: \$0.00 ----- Grand Total: \$79.99
Credit Card transactions	Visa ending in 1058: January 27, 2026: \$79.99

To view the status of your order, return to [Order Summary](#) .



Final Details for Order #111-4324316-2553039

Order Placed: January 30, 2026
Amazon.com order number: 111-4324316-2553039
Order Total: \$31.46

Business order information
Location: DSD - Tamaya GL code: 53206 Special Events Cost Billable / Non-Billable: Non-Billable Cost center: Northeast

Shipped on January 30, 2026	
Items Ordered	Price
1 of: 50 FT Valentine's Day Tinsel Garland Red Pink Heart Shaped Valentine's Day Decorations for Home Table Wedding Anniversary Decor Supplies Sold by: Dolkoic (seller profile) Condition: New	\$9.99
1 of: Beistle Heart Gleam 'N Burst Centerpiece Sold by: Amazon (seller profile) Business Price Condition: New	\$5.50
Shipping Address: Oliver Ingram 12788 MERITAGE BLVD JACKSONVILLE, FL 32246-0705 United States	Item(s) Subtotal: \$15.49 Shipping & Handling: \$0.00 ----- Total before tax: \$15.49 Sales Tax: \$0.00 -----
Shipping Speed: FREE Prime Delivery	Total for This Shipment: \$15.49 -----

Shipped on January 31, 2026	
Items Ordered	Price
1 of: Wonmon 36 Ft Valentine's Day Bulletin Board Border Roll, Valentine Heart Shape Bulletin Border Trim for Valentines Day Wedding Party School Classroom Office Wall Bulletin Boards Decor Sold by: Wonmon (seller profile) Condition: New	\$7.98
Shipping Address: Oliver Ingram 12788 MERITAGE BLVD JACKSONVILLE, FL 32246-0705 United States	Item(s) Subtotal: \$7.98 Shipping & Handling: \$0.00 ----- Total before tax: \$7.98 Sales Tax: \$0.00 -----
Shipping Speed:	-----

FREE Prime Delivery

Total for This Shipment: \$7.98

Shipped on February 1, 2026

Items Ordered

Price

1 of: *Day It Rained Hearts: A Creative Valentine Story About Friendship for Children (Ages 4-8) , Bond, Felicia*

\$7.99

Sold by: Amazon.com

Condition: New

Shipping Address:

Oliver Ingram
12788 MERITAGE BLVD
JACKSONVILLE, FL 32246-0705
United States

Item(s) Subtotal: \$7.99

Shipping & Handling: \$0.00

Total before tax: \$7.99

Sales Tax: \$0.00

Shipping Speed:

FREE Prime Delivery

Total for This Shipment: \$7.99

Payment information

Payment Method:

Visa | Last digits: 1058

Item(s) Subtotal: \$31.46

Shipping & Handling: \$0.00

Total before tax: \$31.46

Estimated Tax: \$0.00

Grand Total: \$31.46

Billing address

Oliver Ingram
12788 MERITAGE BLVD
JACKSONVILLE, FL 32246-0705
United States

Credit Card transactions

Visa ending in 1058: February 1, 2026: \$31.46

To view the status of your order, return to [Order Summary](#) .

[Conditions of Use](#) | [Privacy Notice](#) © 1996-2020, Amazon.com, Inc.



Final Details for Order #111-1357853-3604258

Order Placed: January 28, 2026
Amazon.com order number: 111-1357853-3604258
Order Total: \$44.98

Business order information
Location: DSD - Tamaya GL code: 53206 Special Events Cost Billable / Non-Billable: Non-Billable Cost center: Northeast

Shipped on February 1, 2026	
Items Ordered	Price
1 of: 200 Pcs Football Party Decorations, 5 lb 100 Football Paper Food Trays Disposable Serving Trays Boats with 100 Grease Resistant Liner Papers for Birthday Party Supplies Sport Game Event Favors Sold by: Jineepy (seller profile) Condition: New	\$32.99
1 of: Knitgrip 2 Pack Football Party Decorations Photo Props 3.3x6.6 ft Football Foil Fringe Curtain Backdrop Birthday Party Decorations Sports Background Sold by: Tantenbeller (seller profile) Condition: New	\$11.99
Shipping Address: Oliver Ingram 12788 MERITAGE BLVD JACKSONVILLE, FL 32246-0705 United States	Item(s) Subtotal: \$44.98 Shipping & Handling: \$0.00 ----- Total before tax: \$44.98 Sales Tax: \$0.00 -----
Shipping Speed: Amazon Day Delivery	Total for This Shipment: \$44.98 -----

Payment information	
Payment Method: Visa Last digits: 1058	Item(s) Subtotal: \$44.98 Shipping & Handling: \$0.00 -----
Billing address Oliver Ingram 12788 MERITAGE BLVD JACKSONVILLE, FL 32246-0705 United States	Total before tax: \$44.98 Estimated Tax: \$0.00 ----- Grand Total: \$44.98
Credit Card transactions	Visa ending in 1058: February 1, 2026: \$44.98

To view the status of your order, return to [Order Summary](#) .

Maximum Entertainment

Invoice 338961011

Sold by Mack W.

Created: 02/04/2026 at 03:24 pm ET

Express Item **\$250.00**

Sub-total \$250.00

Tax \$0.00

Tip \$0.00

Total **\$250.00**



Sold to Oliver Ingram **\$250.00**

Visa *1058 (Keyed)

Auth Code: 414042

Maximum Entertainment



Billing Information

Oliver Ingram
 12788 Meritage Blvd
 Jacksonville, FL 32246
 (904)-536-6367

Payment Method
 VISA

**** * 1058

Order Summary

Subtotal	\$296.66
Savings	-\$0.00
Rewards Redeemed	-\$0.00
Shipping Charge	\$0.00
Shipping Discount	\$0.00
Tire Disposal Fee	\$0.00
Tax	\$10.68
Fees 	\$0.00
<hr/>	
Pickup	
Pickup Fee 	\$0.00
<hr/>	
Total	\$307.34
Credit Card	\$307.34

 [Print Receipt](#)
[Return Policy](#)

All BJ's memberships are subject to BJ's current Membership Terms, ask in-club or go to [BJs.com/terms](https://www.bjs.com/terms).

Your membership expires on the last day of the month and year shown. Memberships renewed within two months after expiration will be extended 12 months from the expiration date. Memberships renewed more than two months after expiration will be extended for 12 months from the last day of the month of renewal, provided that BJ's reserves the right to require you to enroll in a new membership in lieu of renewing your expired membership.

⁶BJ's One+™ Credit Card holders earn 5% back in rewards on eligible purchases of goods and services in-club at BJ's front-end registers, on BJs.com or in the BJ's app (minus any redeemed rewards, returns, refunds, or credit adjustments) when they pay for these purchases with their BJ's One+™ Credit Card. Eligible Purchases exclude shipping, sales tax, bottle deposits, alcoholic beverages, cigarettes and tobacco-related products, lottery tickets, gift cards, propane, gasoline, BJ's Gas®, online optical purchases, membership fees and add-ons, warranties and protection plans, BJ's services provided by third parties (e.g., BJ's Travel®), BJ's B2B and BJ's Global Sales transactions. See [BJs.com/bjsoneterms](https://www.bjs.com/bjsoneterms) for information on excluded services. The rewards program is provided by BJ's Wholesale Club, Inc. and its terms may change at any time. For full rewards terms and conditions, please see [BJs.com/bjsoneterms](https://www.bjs.com/bjsoneterms) and [BJs.com/terms](https://www.bjs.com/terms).

Feedback







Pickup
(28 items)

Order Date
02/05/2026

Scheduled Pickup Time
02/05/2026
3:00 PM to 4:00 PM

Pick Up Location
12200 Atlantic Blvd.
Jacksonville, FL 32225

Order Placed Order Processing Ready for Pick Up Order Picked Up

Item Description	Item	Item Price	Qty (Weight)	Total Price
		Item Price : \$14.99 Qty (Weight) : 1 Total Price : \$14.99		
<u>Ring Pops Variety Box, 40 ct.</u> Item: 12792				
<input type="button" value="BUY IT AGAIN"/>				
		Item Price : \$18.49 Qty (Weight) : 1 Total Price : \$18.49		
<u>Dr. Pepper Soda, 36 pk./12 oz. cans</u> Item: 140856				
<input type="button" value="BUY IT AGAIN"/>				
		Item Price : \$5.49 Qty (Weight) : 2 Total Price : \$10.98		
<u>Blueberries, 18 oz.</u> Item: 14153				
<input type="button" value="BUY IT AGAIN"/>				
		Item Price : \$6.99 Qty (Weight) : 2 Total Price : \$13.98		
<u>Beefsteak Tomatoes, 6 ct.</u> Item: 169513				
<input type="button" value="BUY IT AGAIN"/>				
		Item Price : \$2.29 Qty (Weight) : 1 Total Price : \$2.29		

Feedback

Sleeved Celery Stalk

Item: 18004

BUY IT AGAIN



Item Price : \$1.99
Qty (Weight) : 1
Total Price : \$1.99

Wellsley Farms English Seedless Cucumbers, 2 ct.

Item: 187126

BUY IT AGAIN



Item Price : \$4.49
Qty (Weight) : 1
Total Price : \$4.49

Daisy Brand Squeezable Sour Cream Pouches, 2 pk./14 oz.

Item: 194818

BUY IT AGAIN



Item Price : \$7.99
Qty (Weight) : 1
Total Price : \$7.99

Wellsley Farms Mexican Shreds 2 ct./24 oz.

Item: 20044

BUY IT AGAIN



Item Price : \$8.89
Qty (Weight) : 1
Total Price : \$8.89

Bi-Color Seedless Grapes, 3 lbs.

Item: 21524

BUY IT AGAIN



Item Price : \$8.98
Qty (Weight) : 2
Total Price : \$17.96

Tostitos Scoops Tortilla Chips, 2 pk.

Item: 275185002

BUY IT AGAIN



Item Price : \$10.49
Qty (Weight) : 1
Total Price : \$10.49

Cholula Original Hot Sauce, 2 pk./12 fl. oz.

Feedback

Item: 28578

BUY IT AGAIN



Item Price : \$7.99
Qty (Weight) : 1
Total Price : \$7.99

Wholly Guacamole Classic Guacamole Bowls, 3 pk./7.5 oz.

Item: 287089

BUY IT AGAIN



Item Price : \$7.99
Qty (Weight) : 1
Total Price : \$7.99

Wellsley Farms Roasted Corn and Poblano Pepper Queso, 24 oz.

Item: 287461

BUY IT AGAIN



Item Price : \$16.29
Qty (Weight) : 1
Total Price : \$16.29

Gatorade Thirst Quencher Variety, 28 pk./12 fl. oz.

Item: 28833

BUY IT AGAIN



Item Price : \$17.79
Qty (Weight) : 1
Total Price : \$17.79

Gold Peak Sweetened Iced Tea, Bottles, 18 pk./16.9 fl. oz.

Item: 291397

BUY IT AGAIN



Item Price : \$5.99
Qty (Weight) : 1
Total Price : \$5.99

Wild Wonders Gourmet Medley Tomatoes, 1.5 lbs.

Item: 32207

BUY IT AGAIN



Item Price : \$4.99
Qty (Weight) : 1
Total Price : \$4.99

Tres Hermanas Nacho Sliced Jalapenos, 2 pk./12 oz.

Item: 339015

Feedback

BUY IT AGAIN



Item Price : \$11.49
Qty (Weight) : 1
Total Price : \$11.49

Tostitos Medium Chunky Salsa, 2 pk./40.575 oz.

Item: 340894

BUY IT AGAIN



Item Price : \$2.99
Qty (Weight) : 2
Total Price : \$5.98

Fresh Express Shreds, Shredded Iceberg Lettuce, 14 oz.

Item: 349864

BUY IT AGAIN



Item Price : \$19.79
Qty (Weight) : 1
Total Price : \$19.79

Coca-Cola Soda Soft Drink, Cans, 35 pk./12 fl. oz.

Item: 38045

BUY IT AGAIN



Item Price : \$19.79
Qty (Weight) : 1
Total Price : \$19.79

Sprite Lemon-Lime Caffeine Free Soda Soft Drink, Cans, 35 pk./12 fl. oz.

Item: 38046

BUY IT AGAIN



Item Price : \$19.79
Qty (Weight) : 1
Total Price : \$19.79

Diet Coke Soda Soft Drink, Cans, 35 pk./12 fl. oz.

Item: 38048

BUY IT AGAIN



Item Price : \$15.49
Qty (Weight) : 1
Total Price : \$15.49

Propel Fitness Water Variety Pack, 24 pk./16.9 oz.

Item: 52430

Feedback

BUY IT AGAIN



Item Price : \$3.99
Qty (Weight) : 1
Total Price : \$3.99

Wellsley Farms Purified Water, 40 pk./16.9 oz.

Item: 53620

BUY IT AGAIN



Item Price : \$8.99
Qty (Weight) : 1
Total Price : \$8.99

Goya Black Beans, 8 pk./15.5 oz.

Item: 60525

BUY IT AGAIN



Item Price : \$9.99
Qty (Weight) : 1
Total Price : \$9.99

Wellsley Farms Brownie Bites, 32 ct.

Item: 72131

BUY IT AGAIN



Item Price : \$3.29
Qty (Weight) : 1
Total Price : \$3.29

Wellsley Farms Limes, 2 lbs.

Item: 86789

BUY IT AGAIN



Item Price : \$4.49
Qty (Weight) : 1
Total Price : \$4.49

Wellsley Farms Mixed Peppers, 4 ct.

Item: 97262

BUY IT AGAIN

Feedback

Order Details



Pickup
(28 items)

Super Bowl Event



12200 ATLANTIC BLVD.
JACKSONVILLE, FL
Club Mgr. Jeffrey Wellesley

Club:108 Reg:6 Trans:4674
Cashier:575554 02/05/26 04:24pm

*** MEMBERSHIP ID. *****6285 ***
*** MEMBERSHIP EXPIRES ON 10/26 ***

BEACH CDD
3501 QUADRANGLE BLVD STE 270
ORLANDO, FL 32817-8329
R 0858013855552 FL 05/31/27

60654000756	QFX SPEAKER	249.99 R
2222878	CCPN-QFX SPE	70.00-N
20999200000	GB 80	24.55 N
20999200000	GB 80	25.65 N
20999200000	GB 80	24.65 N
**** SUBTOTAL		254.84
**** TOTAL		254.84

*****1058 ENTRY: H
Purchase 00 APPROVED
AUTH 515062
TERMINAL NUMBER 7807301086
02/05/26 04:26pm 108 6 4674 575554
VISA CREDIT
AID: A0000000031010

Visa	254.84
CHANGE	0.00
TOTAL ITEMS=	4

As a BJ's Member I JUST SAVED: \$134.97
BJ's Member Savings 64.97
Coupons Redeemed 70.00
Rewards Redeemed 0.00

Current BJ's Gas Savings
FuelSaver earned thru 02/04/26 0.00/gal
FuelSaver earned in this trx: 0.00/gal
Visit BJ's.com/Gas for more details

RESALE CERTIFICATE
WILL EXPIRE IN 480 DAYS

SAVE TIME ON YOUR NEXT SHOP
Skip the checkout line with ExpressPay
Scan items, clip coupons & pay
with the BJ's app.



MEMBER COPY



0205108064674

Super Bowl Event

Give us feedback @ survey.walmart.com
Thank you! ID #:7WQWDXF88BP

Walmart

WM Supercenter
904-272-0036 Mgr: JULIAN
899 BLANDING BLVD
ORANGE PARK FL 32065

ST# 01225 OP# 007454 TE# 73 TR# 02120
ITEMS SOLD 1
TC# 1396 9753 9264 0917 509



SITE MERCH	068113131061	8.98	X
	SUBTOTAL	8.98	
SITE MERCH	068113131061	8.98	0
** VOIDED ENTRY **			
SITE MERCH	068113131061	8.98	0
SITE MERCH	068113131061	8.98	0
	SUBTOTAL	17.96	
** VOIDED ENTRY **			
SITE MERCH	068113131061	8.98	0
** VOIDED ENTRY **			
SITE MERCH	068113131061	8.98	X
SITE MERCH	068113131061	8.98	0
	SUBTOTAL	8.98	
	TOTAL	8.98	
	VISA TEND	8.98	

VISA CREDIT ***** 1058 I 2

APPROVAL # 018010

REF # U661NM519231

TRANS ID - 386039576781933

VALIDATION - Q56X

PAYMENT SERVICE - E

AID A0000000031010

AAC D9DE48931BB9AC46

TERMINAL # 21972767

*NO SIGNATURE REQUIRED

02/08/26

11:01:20

CHANGE DUE

0.00

CUSTOMER COPY



Get free delivery
from this store
with Walmart+

Scan for 30-day free trial.

02/08/26

11:01:28

Super Bowl Event

Publix

Kernan Square
12620 Beach Blvd Ste 12
Jacksonville, FL 32246-7130
(904) 564-3580

Store Manager: Saneathia McIntyre

16 Lb. Ice	FT	
\$5.99 x 3		17.97
Subtotal		17.97
Sales Tax 7.5% - T		0.00
Total Tax		0.00
Total		17.97
Credit		17.97
Change		0.00
Tax Exempt		1.35

Visa: *1058	\$17.97
Credit Card	Purchase
Auth/Trace: 518015/059568	Ctl's
Reference: 005296031120	
A0000000031010	
VISA CREDIT	

02/08/2026 04:51PM

Thank you for shopping at store 0644
Your cashier today was Kellie.
9892, 0105, 262

Club Publix members save more.
Join today at clubpublix.com/newmember.
Terms & conditions apply.

Publix Super Markets, Inc.



0644 28R 059 892



Final Details for Order #111-9956453-3559421

Order Placed: February 4, 2026
Amazon.com order number: 111-9956453-3559421
Order Total: \$125.91

Business order information
Location: DSD - Tamaya
GL code: 53206 Special Events Cost
Billable / Non-Billable: Non-Billable
Cost center: Northeast

Shipped on February 4, 2026

Items Ordered Price
1 of: 150 Pack Mochi Squishy Toys... \$23.98
1 of: Cherisply 24 Pack Prefilled Easter Eggs... \$12.99
2 of: 60PCS Small Hatching Dinosaur Eggs... \$14.99
2 of: Easter Basket Stuffers for Kids... \$8.49
1 of: OHOME Easter Stickers | 120 PCS Egg Bunny Stickers... \$6.99

Shipping Address: Oliver Ingram, 12788 MERITAGE BLVD, JACKSONVILLE, FL 32246-0705, United States
Shipping Speed: FREE Prime Delivery
Item(s) Subtotal: \$90.92
Shipping & Handling: \$0.00
Total before tax: \$90.92
Sales Tax: \$0.00
Total for This Shipment: \$90.92

Shipped on February 8, 2026

Items Ordered

Price

1 of: 500Pcs Easter Eggs, 2.3" Fillable Colorful Bright Plastic Easter Eggs Empty for Easter Hunt, Filling Treats, Easter Basket Stuffers Fillers, Party Favors, Classroom Prize Supplies Decoration
Sold by: SUNXUN ([seller profile](#))
Condition: New

\$34.99

Shipping Address:

Oliver Ingram
12788 MERITAGE BLVD
JACKSONVILLE, FL 32246-0705
United States

Item(s) Subtotal: \$34.99

Shipping & Handling: \$0.00

Total before tax: \$34.99

Sales Tax: \$0.00

Shipping Speed:

FREE Prime Delivery

Total for This Shipment: \$34.99

Payment information

Payment Method:

Visa | Last digits: 1058

Item(s) Subtotal: \$125.91

Shipping & Handling: \$0.00

Total before tax: \$125.91

Estimated Tax: \$0.00

Billing address

Oliver Ingram
12788 MERITAGE BLVD
JACKSONVILLE, FL 32246-0705
United States

Grand Total: \$125.91

Credit Card transactions

Visa ending in 1058: February 8, 2026: \$125.91

To view the status of your order, return to [Order Summary](#) .

[Conditions of Use](#) | [Privacy Notice](#) © 1996-2020, Amazon.com, Inc.

Story Time
Publix

Kernan Square Shopping Center
 12620 Beach Boulevard
 Jacksonville, FL 32246
 Store Manager: Saneathia McIntyre
 904-564-3580



0644 2FR 032 654

JJ SLIM PNCH JC 8P	4.69	F
JJ SLIM APPL JC 8P	4.69	F
PAW PATROL STRING	5.69	F
MOT A/S VTY NSA 12	9.79	F
ANNIES VARIETY PK	7.99	F
24CT ASSORTED CKIE	4.99	F
You Saved	1.00	
CPCKE MINI 12CT VA	5.29	F
STRAWBERRIES		
1 @ 3 FOR 10.00	3.34	F
You Saved	0.65	
STRAWBERRIES		
1 @ 3 FOR 10.00	3.33	F
You Saved	0.65	
RASPBERRIES RED	4.99	F
RASPBERRIES RED	4.99	F
RASPBERRIES RED	4.99	F
BLUEBERRIES 11OZ		
1 @ 2 FOR 10.00	5.00	F
You Saved	0.99	
BLUEBERRIES 11OZ		
1 @ 2 FOR 10.00	5.00	F
You Saved	0.99	
Order Total	74.77	
Sales Tax	0.00	
Grand Total	74.77	
Credit	Payment	74.77
Change	0.00	

Savings Summary

Special Price Savings 4.28

 * Your Savings at Publix *
 * 4.28 *

Receipt ID: 0644 2FR 032 654

PRESTO!
 Trace #: 036398
 Reference #: 1210121403
 Acct #: XXXXXXXXXXXX1058
 Purchase VISA
 Amount: \$74.77
 Auth #: 115103

CREDIT CARD	PURCHASE
A0000000031010	VISA CREDIT
Entry Method:	Cntctless
Mode:	Issuer

Your cashier was Kara

02/15/2026 12:30 S0644 R103 2654 C0221

Join the Publix family!
 Apply today at apply.publix.jobs.
 We're an equal opportunity employer.

Publix Super Markets, Inc.



[Print](#)

Billing Activity - Invoices

Vesta Property Services, Inc.

*Attn: Oliver Ingram
12788 Meritage Blvd.
Jacksonville FL 32246
US
P.: 904 844 6834*

Today's Date: 03/02/2026

User Name: tamayalifestyles1@gmail.com

Invoices from 01/31/2026 to 03/02/2026

Date	Description	Charge Amount	Credit Amount
02/16/2026	Invoice #1771230583	\$62.00	
	Constant Contact - Core 501-1500 Contacts Highest contact count: 1225 From 01/16/2026 to 02/16/2026	\$62.00	

Billing questions? [Contact Support](#)

Constant Contact - 890 Winter St - Waltham, MA 02451 US

Bouncers & Cupcakes



Let Bouncers & Cupcakes know how your experience was

\$480.00

Custom Amount \$480.00

Total \$480.00

Ron's Receipts

February 2026



BEACH CDD

Receipt # 6365-51-8018

PO/Job Name: tamaya

In-Store Purchase

Order Origin: #6365, Atlantic And Girvin

Ordered
1/22/2026

Item Description	Qty	Unit Price	Discount	Net Unit Price	Pre Tax Amount
ONE+ 18V Cordless 6-Tool Combo Kit with 1.5 Ah Battery, 4.0 Ah Battery, and Charger SKU 1006703284	1	\$299.00	\$0.00	\$299.00	\$199.00
14 oz. Citrus Solid Odor Absorber, Odor Eliminator for Smoke Odor & Musty Smell in Home, Bathroom, Kitchen, Pet Areas SKU 1005072380	2	\$5.47	\$0.00	\$5.47	\$10.94

SAWZALL Wood and Metal Cutting Bi-Metal Reciprocating Saw Blade Set (10-Piece)	1	\$20.97	\$0.00	\$20.97	\$20.97
---	---	---------	--------	---------	---------

SKU 1002800035

2 lb. 4,000 sq. ft. Outdoor Fire Ant Killer Granule Bait for Mounds and Lawns	1	\$21.47	\$0.00	\$21.47	\$21.47
--	---	---------	--------	---------	---------

SKU 519680

Subtotal	\$252.38
Discount	\$0.00
Shipping	\$0.00
Delivery Charge	\$0.00
Sales Tax	\$0.00
Order Total	\$252.38



BEACH CDD

Receipt # 6365-62-6477

PO/Job Name: tamaya

In-Store Purchase

Order Origin: #6365, Atlantic And Girvin

Ordered
1/23/2026

Item Description	Qty	Unit Price	Discount	Net Unit Price	Pre Tax Amount
Extreme Stretch 10.1 oz. White Premium Crackproof Elastomeric Sealant SKU 1002433417	2	\$8.48	\$0.00	\$8.48	\$16.96
60-Watt Equivalent A19 Non-Dimmable CEC LED Light Bulb with Selectable Color Temperature (16-Pack) SKU 1012823219	1	\$19.98	\$0.00	\$19.98	\$17.98
				Subtotal	\$34.94
				Discount	\$0.00

Shipping	\$0.00
Delivery Charge	\$0.00
Sales Tax	\$0.00
Order Total	\$34.94



West Marine®

14180 Beach Blvd Ste 4
Jacksonville, FL 32250-1594
904-821-5033
Visit us at westmarine.com

Qty	Price	Total
Caulk-291FC Wh 10oz	174490	
1	27.99	27.99
	Subtotal	27.99
	Sales Tax	2.10
	Total	30.09

AMOUNT:USD 30.09

CARD:VISA CREDIT XXXX8047 CREDIT EMV

APPROVAL :113243

AID:A0000000031010

APPLICATION PREFERRED NAME:VISA CREDIT

APPLICATION LABEL:VISA CREDIT

Transaction Type: Sale

Entry Method: Insert -ICC

0.00

Change

Thank you for shopping at West Marine, for
our Return Policy visit westmarine.com

Store#: 569 Register#: 2 Trx#: 1129

Date: 1/23/26 Time: 12:34 PM

Cashier: Craig



910569021129260237



Final Details for Order #112-0382569-7793052

Order Placed: January 27, 2026
PO number : tamaya
Amazon.com order number: 112-0382569-7793052
Seller's order number: AZM103582111
Order Total: \$47.09

Business order information
Location: DSD - Tamaya GL code: 14000 Prepaid Expense Billable / Non-Billable: Non-Billable Cost center: Northeast

Shipped on January 27, 2026	
Items Ordered	Price
1 of: <i>Toro 250 Valve P-Type NPT Female Valve with Flow Control, 1"</i> Sold by: Sprinkler Warehouse (seller profile) Condition: New	\$47.09
Shipping Address: Ron Zastrocky 12788 MERITAGE BLVD JACKSONVILLE, FL 32246-0705 United States	Item(s) Subtotal: \$47.09 Shipping & Handling: \$0.00 ----- Total before tax: \$47.09 Sales Tax: \$0.00 -----
Shipping Speed: Standard Shipping	Total for This Shipment: \$47.09 -----

Payment information	
Payment Method: Visa Last digits: 8047	Item(s) Subtotal: \$47.09 Shipping & Handling: \$0.00 -----
Billing address Ron Zastrocky 12788 MERITAGE BLVD JACKSONVILLE, FL 32246-0705 United States	Total before tax: \$47.09 Estimated Tax: \$0.00 ----- Grand Total: \$47.09
Credit Card transactions	Visa ending in 8047: January 27, 2026: \$47.09

To view the status of your order, return to [Order Summary](#) .



Final Details for Order #113-2664140-2361014

Order Placed: January 28, 2026
PO number : tamaya
Amazon.com order number: 113-2664140-2361014
Order Total: \$62.98

Business order information
Location: DSD - Tamaya
GL code: 14000 Prepaid Expense
Billable / Non-Billable: Non-Billable
Cost center: Northeast

Shipped on January 28, 2026
Items Ordered Price
2 Of: Amazon Fire TV Stick HD (newest model), free and live TV, Alexa Voice Remote, smart home controls, HD streaming \$31.49
Sold by: Amazon (seller profile)
Condition: New
Shipping Address: Ron Zastrocky, 12788 MERITAGE BLVD, JACKSONVILLE, FL 32246-0705, United States
Shipping Speed: FREE Prime Delivery
Item(s) Subtotal: \$62.98
Shipping & Handling: \$0.00
Total before tax: \$62.98
Sales Tax: \$0.00
Total for This Shipment: \$62.98

Payment information
Payment Method: Visa | Last digits: 8047
Billing address: Ron Zastrocky, 12788 MERITAGE BLVD, JACKSONVILLE, FL 32246-0705, United States
Item(s) Subtotal: \$62.98
Shipping & Handling: \$0.00
Total before tax: \$62.98
Estimated Tax: \$0.00
Grand Total: \$62.98
Credit Card transactions Visa ending in 8047: January 28, 2026: \$62.98

To view the status of your order, return to Order Summary .



Final Details for Order #113-3528976-4856226

Order Placed: January 30, 2026
PO number : tamaya
Amazon.com order number: 113-3528976-4856226
Order Total: \$14.73

Business order information
Location: DSD - Tamaya
GL code: 14000 Prepaid Expense
Billable / Non-Billable: Non-Billable
Cost center: Northeast

Shipped on February 2, 2026
Items Ordered Price
1 Of: Socket Set Screws DGBRSM 25pcs 10#-32 x 1/4" Stainless Steel Allen Head Hex Hexagon Socket Set Screws Cup Point wit h Hex Key Wrench(Dia.4.6mm, Length 6.3mm) \$6.45
Sold by: BAIRONG (seller profile)
Business Price
Condition: New
1 Of: Bosch BDT1032 10-32 Plug Tap and No. 21 Drill Bit Combo Set \$8.28
Sold by: Amazon (seller profile)
Business Price
Condition: New
Shipping Address: Ron Zastrocky 12788 MERITAGE BLVD JACKSONVILLE, FL 32246-0705 United States
Shipping Speed: FREE Prime Delivery
Item(s) Subtotal: \$14.73
Shipping & Handling: \$0.00
Total before tax: \$14.73
Sales Tax: \$0.00
Total for This Shipment: \$14.73

Payment information
Payment Method: Visa | Last digits: 8047
Billing address: Ron Zastrocky 12788 MERITAGE BLVD JACKSONVILLE, FL 32246-0705 United States
Item(s) Subtotal: \$14.73
Shipping & Handling: \$0.00
Total before tax: \$14.73
Estimated Tax: \$0.00
Grand Total: \$14.73

Credit Card transactions Visa ending in 8047: February 2, 2026: \$14.73

To view the status of your order, return to Order Summary .

US BANK STATEMENTS

February 2026



February 2026 Statement

Open Date: 01/24/2026 Closing Date: 02/23/2026

Account Ending in: ##### ##### ##### 8538

U.S. Bank Visa® Rewards Community Card
BEACH CDD (CPN 002750410)

Cardmember Service ☎ 1-866-485-4545
BUS 30 USB 15

New Balance	\$2,659.92
Minimum Payment Due	\$2,659.92
Payment Due Date	03/22/2026

Late Payment Warning: As a reminder, your card is a pay in full product. If we do not receive your payment in full by the date listed above, a fee of either 3.00% of the payment due or \$39.00 minimum, whichever is greater, will apply.

Cash Rewards	
Earned This Statement	\$26.60
Rewards Center Balance as of 02/23/2026	\$709.97

For details, see your rewards summary.

Activity Summary		
Previous Balance	+	\$3,375.23
Payments	-	\$3,375.23 ^{CR}
Other Credits		\$0.00
Purchases	+	\$2,659.92
Balance Transfers		\$0.00
Advances		\$0.00
Other Debits		\$0.00
Fees Charged		\$0.00
Interest Charged		\$0.00
New Balance	=	\$2,659.92
Past Due		\$0.00
Minimum Payment Due		\$2,659.92
Credit Line		\$20,000.00
Available Credit		\$17,340.08
Days in Billing Period		31

Payment Options:



Mail payment coupon with a check



Pay online at usbank.com



Pay by phone 1-866-485-4545



Pay at your local U.S. Bank branch

No payment is required.

CPN 002750410



0047985319214485380002659920002659926

Automatic Payment

24-Hour Cardmember Service: 1-866-485-4545

- ☎ . to pay by phone
- ☎ . to change your address

Account Ending in: ##### ##### ##### 8538
Your new full balance of \$2,659.92 will be automatically deducted from your account on 03/20/26.

106481750554137 E

BEACH CDD

 ACCOUNTS PAYABLE

 12788 MERITAGE BLVD

 JACKSONVILLE FL 32246-0705

What To Do If You Think You Find A Mistake On Your Statement

If you think there is an error on your statement, please call us at the telephone number on the front of this statement, or write to us at: Cardmember Service, P.O. Box 6335, Fargo, ND 58125-6335.

In your letter or call, give us the following information:

- ▶ **Account information:** Your name and account number.
 - ▶ **Dollar amount:** The dollar amount of the suspected error.
 - ▶ **Description of Problem:** If you think there is an error on your bill, describe what you believe is wrong and why you believe it is a mistake.
- You must contact us within 60 days after the error appeared on your statement. While we investigate whether or not there has been an error, the following are true:
- ▶ We cannot try to collect the amount in question, or report you as delinquent on that amount.
 - ▶ The charge in question may remain on your statement, and we may continue to charge you interest on that amount. But, if we determine that we made a mistake, you will not have to pay the amount in question or any interest or other fees related to that amount.
 - ▶ While you do not have to pay the amount in question, you are responsible for the remainder of your balance.
 - ▶ We can apply any unpaid amount against your credit limit.

Your Rights If You Are Dissatisfied With Your Credit Card Purchases

If you are dissatisfied with the goods or services that you have purchased with your credit card, and you have tried in good faith to correct the problem with the merchant, you may have the right not to pay the remaining amount due on the purchase.

To use this right, all of the following must be true:

1. The purchase must have been made in your home state or within 100 miles of your current mailing address, and the purchase price must have been more than \$50. (Note: Neither of these are necessary if your purchase was based on an advertisement we mailed to you, or if we own the company that sold you the goods or services.)
2. You must have used your credit card for the purchase. Purchases made with cash advances from an ATM or with a check that accesses your credit card account do not qualify.
3. You must not yet have fully paid for the purchase.

If all of the criteria above are met and you are still dissatisfied with the purchase, contact us in writing at: Cardmember Service, P.O. Box 6335, Fargo, ND 58125-6335

While we investigate, the same rules apply to the disputed amount as discussed above. After we finish our investigation, we will tell you our decision. At that point, if we think you owe an amount and you do not pay we may report you as delinquent.

Important Information Regarding Your Account

1. **INTEREST CHARGE:** Method of Computing Balance Subject to Interest Rate: We calculate the periodic rate or interest portion of the **INTEREST CHARGE** by multiplying the applicable Daily Periodic Rate ("**DPR**") by the Average Daily Balance ("**ADB**") (including new transactions) of the Purchase, Advance and Balance Transfer categories subject to interest, and then adding together the resulting interest from each category. We determine the **ADB** separately for the Purchases, Advances and Balance Transfer categories. To get the **ADB** in each category, we add together the daily balances in those categories for the billing cycle and divide the result by the number of days in the billing cycle. We determine the daily balances each day by taking the beginning balance of those Account categories (including any billed but unpaid interest, fees, credit insurance and other charges), adding any new interest, fees, and charges, and subtracting any payments or credits applied against your Account balances that day. We add a Purchase, Advance or Balance Transfer to the appropriate balances for those categories on the later of the transaction date or the first day of the statement period. Billed but unpaid interest on Purchases, Advances and Balance Transfers is added to the appropriate balances for those categories each month on the statement date. Billed but unpaid Advance Transaction Fees are added to the Advance balance of your Account on the date they are charged to your Account. Any billed but unpaid fees on Purchases, credit insurance charges, and other charges are added to the Purchase balance of the Account on the date they are charged to the Account. Billed but unpaid fees on Balance Transfers are added to the Balance Transfer balance of the Account on the date they are charged to the Account. In other words, billed and unpaid interest, fees, and charges will be included in the **ADB** of your Account that accrues interest and will reduce the amount of credit available to you. To the extent credit insurance charges, overlimit fees, Annual Fees, and/or Travel Membership Fees may be applied to your Account, such charges and/or fees are not included in the **ADB** calculation for Purchases until the first day of the billing cycle following the date the credit insurance charges, overlimit fees, Annual Fees and/or Travel Membership Fees (as applicable) are charged to the Account. Prior statement balances subject to an interest-free period that have been paid on or before the payment due date in the current billing cycle are not included in the **ADB** calculation. If you do not pay your New Balance in full by the Payment Due Date, you will not get an interest-free period on Purchases again until you pay the New Balance in full by the Payment Due Date for two billing cycles in a row.

2. **Payment Information:** We will accept payment via check, money order, the internet (including mobile and online) or phone or previously established automatic payment transaction. You must pay us in U.S. Dollars. If you make a payment from a foreign financial institution, you will be charged and agree to pay any collection fees added in connection with that transaction. The date you mail a payment is different than the date we receive the payment. The payment date is the day we receive your check or money order at U.S. Bank National Association, P.O. Box 790408, St. Louis, MO 63179-0408 or the day we receive your internet or phone payment. All payments by check or money order accompanied by a payment coupon and received at this payment address will be credited to your Account on the day of receipt if received by 5:00 p.m. CT on any banking day. Payments sent without the payment coupon or to an incorrect address will be processed and credited to your Account within 5 banking days of receipt. Payments sent without a payment coupon or to an incorrect address may result in a delayed credit to your Account, additional interest charges, fees, and/or Account suspension. The deadline for on-time internet and phone payments varies, but generally must be made before 5:00 p.m. CT to 8 p.m. CT depending on what day and how the payment is made. Please contact Cardmember Service for internet, phone, and mobile crediting times specific to your Account and your payment option. Banking days are all calendar days except Saturday, Sunday and federal holidays. Payments due on a Saturday, Sunday or federal holiday and received on those days will be credited on the day of receipt. There is no prepayment penalty if you pay your balance at any time prior to your payment due date.

3. **Credit Reporting:** We may report information on your Account to Credit Bureaus. Late payments, missed payments or other defaults on your Account may be reflected in your credit report.



Visa Company Rewards

Rewards Center Activity as of 02/23/2026	
Rewards Center Activity*	\$0.00
Rewards Center Balance	\$709.97

To Redeem or check your Rewards Balance:
Download the U.S. Bank Mobile App or login to usbank.com to access the Rewards Center, or call 1-888-229-8864.

	This Statement	Year to Date
Reward Dollars Earned		
Cash Rewards	\$26.60	\$60.35
Total Earned	\$26.60	\$60.35

Important Messages

Paying Interest: You have a 24 to 30 day interest-free period for Purchases provided you have paid your previous balance in full by the Payment Due Date shown on your monthly Account statement. In order to avoid additional INTEREST CHARGES on Purchases, you must pay your new balance in full by the Payment Due Date shown on the front of your monthly Account statement.

There is no interest-free period for transactions that post to the Account as Advances or Balance Transfers except as provided in any Offer Materials. Those transactions are subject to interest from the date they post to the Account until the date they are paid in full.

Your payment of \$2659.92 will be automatically deducted from your bank account on 03/20/2026. Please refer to your AutoPay Terms and Conditions for further information regarding this account feature.

Transactions INGRAM,OLIVER E Credit Limit \$5000

Post Date	Trans Date	Ref #	Transaction Description	Amount	Notation
Purchases and Other Debits					
01/26	01/23	6205	BJS.COM #5490 800-257-2582 MA	\$213.07	_____
01/26	01/23	1068	AMAZON MKTPL*KD3L13PK3 Amzn.com/bill WA	\$99.99	_____
01/26	01/23	0442	Amazon.com*LQ02E0GV3 Amzn.com/bill WA	\$29.95	_____
01/26	01/23	6256	Amazon.com*BY2WA17Y3 Amzn.com/bill WA	\$16.50	_____
01/28	01/28	5233	AMAZON MKTPL*OZ5EK0AG3 Amzn.com/bill WA	\$119.96	_____
01/28	01/28	8376	Amazon.com*P012O0D53 Amzn.com/bill WA	\$79.99	_____
02/02	02/01	0017	AMAZON MKTPL*ZC6W55MB3 Amzn.com/bill WA	\$31.46	_____
02/02	02/01	2972	AMAZON MKTPL*GK16O5AR3 Amzn.com/bill WA	\$44.98	_____
02/05	02/04	5106	PAW*MAXIMUM ENTERTAINM JACKSONVILLE FL	\$250.00	_____
02/06	02/05	9075	BJS.COM #5490 800-257-2582 MA	\$307.34	_____
02/06	02/05	9158	BJS WHOLESALE #0108 JACKSONVILLE FL	\$254.84	_____
02/09	02/08	7392	WM SUPERCENTER #1225 ORANGE PARK FL	\$8.98	_____
02/09	02/08	5755	PUBLIX #644 JACKSONVILLE FL	\$17.97	_____
02/09	02/08	6160	AMAZON MKTPL*W517G1LY3 Amzn.com/bill WA	\$125.91	_____
02/17	02/15	6064	PUBLIX #644 JACKSONVILLE FL	\$74.77	_____
02/17	02/16	7827	CCI*CONSTANT-CONTACT 855-2295506 MA	\$62.00	_____
02/19	02/18	2188	SQ *BOUNCERS & CUPCAKE ORANGE PARK FL	\$480.00	_____
Total for Account ##### 1058				\$2,217.71	



Transactions ZASTROCKY, RONALD W Credit Limit \$5000

Post Date	Trans Date	Ref #	Transaction Description	Amount	Notation
Purchases and Other Debits					
01/26	01/22	7374	THE HOME DEPOT 6365 JACKSONVILLE FL	\$252.38	_____
01/26	01/23	4733	THE HOME DEPOT #6365 JACKSONVILLE FL	\$34.94	_____
01/26	01/23	5698	WEST MARINE #569 JACKSONVILLE FL	\$30.09	_____
01/28	01/27	0796	AMAZON MKTPL*BL8UE1JD2 Amzn.com/bill WA	\$47.09	_____
01/29	01/28	9869	Amazon.com*RP9UD1XK3 Amzn.com/bill WA	\$62.98	_____
02/03	02/03	6743	AMAZON MKTPL*SZ0UP86O3 Amzn.com/bill WA	\$14.73	_____
Total for Account ##### 8047				\$442.21	

Transactions BILLING ACCOUNT ACTIVITY

Post Date	Trans Date	Ref #	Transaction Description	Amount	Notation
Payments and Other Credits					
02/20	02/20	MTC	PAYMENT THANK YOU	\$3,375.23CR	_____
Total for Account ##### 8538				\$3,375.23CR	

2026 Totals Year-to-Date	
Total Fees Charged in 2026	\$0.00
Total Interest Charged in 2026	\$0.00

Interest Charge Calculation

Your Annual Percentage Rate (APR) is the annual interest rate on your account.

**APR for current and future transactions.

Balance Type	Balance By Type	Balance Subject to Interest Rate	Variable	Interest Charge	Annual Percentage Rate	Expires with Statement
**BALANCE TRANSFER	\$0.00	\$0.00		\$0.00	0.00%	
**PURCHASES	\$2,659.92	\$0.00		\$0.00	0.00%	
**ADVANCES	\$0.00	\$0.00		\$0.00	0.00%	



February 2026 Statement 01/24/2026 - 02/23/2026
BEACH CDD (CPN 002750410)

Page 4 of 4
Cardmember Service ☎ 1-866-485-4545

Contact Us

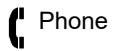

Voice: 1-866-485-4545
TDD: 1-888-352-6455
Fax: 1-866-807-9053



Questions
Cardmember Service
P.O. Box 6353
Fargo, ND 58125-6353



Mail payment coupon
with a check
U.S. Bank
P.O. Box 790408
St. Louis, MO 63179-0408



Online
usbank.com

End of Statement

BEACH CDD

Earn more rewards: update your email address at usbank.com.

Dont miss out on exclusive reward offers and important updates. Make sure we have your current email address by updating your profile at usbank.com and opting into marketing messages.

You may change your email marketing preferences at any time in the Privacy section of usbank.com. Note that confidential, personal or financial information will never be sent or requested in an email from U.S. Bank.

EXHIBIT 10

Integrated Access Solutions, LLC
2227 Crystal Cove Dr.
Green Cove Springs, FL
32043-9604 USA
Service@iasnfl.com



Estimate

ADDRESS

Beach CDD Tamaya
12788 Meritage Blvd.
Jacksonville, FL. 32246

ESTIMATE # 2895
DATE 03/24/2026

DATE	ACTIVITY	DESCRIPTION	QTY	RATE	AMOUNT
03/24/2026	Gate Repair	Repair of aluminum pedestrian gate. Includes pickup, repair, delivery, and installation	1	1,280.00	1,280.00T

Contact Integrated Access Solutions, LLC to pay.
Estimate is valid for 30 days from date of estimate.

SUBTOTAL 1,280.00
TAX 0.00
TOTAL **\$1,280.00**

IAS shall retain a security interest in all goods and materials until same has been paid in full. Buyer/owner agrees to pay all collection and attorney fees, as well as a 1.5% per month service charge on all past due amounts. All terms and scope of work for this contract are contained herein.

Workmanship warranty is one year from install date.

Manufacturer warranties are per manufacturer.

Payment terms will be 50% down and 50% upon completion of job.

Accepted By

Accepted Date

EXHIBIT 11

Morgan Inland LLC
380 TENNANT AVE. UNIT 3.

MORGAN HILL, California, 95037
United States

Tel: 415-704-8713
Fax: -

URL: www.miatlantic.us

SO No.

Date

Quote No.

Customer Po No.

Sales Rep.

Payment Terms

MIL-SO-25497

04/03/2026

MIL-34703

Email

Kaleb Hurt

Prepaid

Customer ID: MIL-16752

Customer VAT#: -

Bill to Address
Pawel Szeszko Beach Community Development District 250 International Parkway, Suite 208 Lake Mary, FL, 32746 United States

Ship to Address
Tamaya Ron Zastrocky Beach Community Development District 12788 Meritage Blvd Jacksonville, FL, 32246 United States Tel: 8609872359

Sr.#	Part# Description	Condition	ETA	Qty	Unit Price	Amount
1	UDM-Pro-Max Ubiquiti Dream Machine Pro Max	Brand New	10 - 14 Working Days	1	650.00	650.00
2	UNVR-Pro Ubiquiti Networks UNVR-PRO UniFi Protect NVR Pro (No HDD)	Brand New	In Stock	1	535.00	535.00
3	USW-PRO-MAX-48-POE 48+4P Ubiquiti UniFi USW-PRO-Max-48-PoE PoE++ 720W M RM	Brand New	In Stock	2	1,215.00	2,430.00
4	UVC-G6-Turret-W Ubiquiti UVC-G6-Turret-W UniFi Video Camera G6 Turret White	Brand New	In Stock	12	224.00	2,688.00
5	UVC-G6-Pro-Turret-W Ubiquiti UniFi G6 Pro Turret Camera - White (UVC-G6-Pro-Turret-W)	Brand New	In Stock	12	580.00	6,960.00
6	U7-PRO-MAX-US Ubiquiti Networks UniFi U7 Pro Max US Model (U7-Pro-Max)	Brand New	In Stock	2	275.00	550.00
7	U7-OUTDOOR-US Ubiquiti U7-Outdoor	Brand New	In Stock	2	199.00	398.00
8	U7-PRO-OUTDOOR-US Ubiquiti U7 Pro Outdoor WiFi 7 Access Point, IP67 Rated, 6 GHz AFC Support, U7-Pro-Outdoor	Brand New	In Stock	5	275.00	1,375.00
9	UDB-PRO-SECTOR-US Ubiquiti - UDB-Pro-Sector	Brand New	2 - 3 Weeks	1	223.00	223.00

All Quotations/Sale Orders and subsequent orders are subject to compliance to our standard terms & conditions unless stated otherwise.

- See Terms and Conditions of sale at <https://miatlantic.net/terms>

- No returns accepted without prior authorization. See Return Policy at <https://miatlantic.net/return-policy>

POPULAR BRANDS - WE DEAL WITH



Experience State of the Art Online Business REGISTER as customer at www.miatlantic.us

10	UDB-PRO-US Ubiquiti UniFi Device Bridge Pro	Brand New	In Stock	2	230.00	460.00
11	USW-FLEX Ubiquiti Networks UniFi USW-FLEX Managed L2 Gigabit Ethernet (101001000) White Power over Ethernet (PoE)	Brand New	In Stock	2	105.00	210.00
12	U-POE++ PoE++ Adapter (60W)	Brand New	In Stock	2	28.00	56.00
13	ST16000VE004 Seagate Skyhawk AI 16TB, Video Internal Hard Drive, 3.5 Inch, SATA, 6Gbs, 256MB Cache, for DVRNVR Security Camera System, Data Rescue Service (ST16000VE004)	Brand New	2 - 3 Weeks	5	415.00	2,075.00

PLEASE REMIT USING BELOW BANK DETAIL ONLY

Beneficiary Name : Morgan Inland LLC
 Bank Name : Bank of America
 Currency : USD
 Account Number : 325208140162
 Sort Code : Fedwire Routing # 026009593
 Swift Code (BIC) : BOFAUS3N
 IBAN Number : -
 Bank Address : 5710 Cottle Rd, San Jose, CA 95123
 Country : United States

SUB TOTAL	18,610.00
SHIPPING	710.00
SaleTax(6.00%)	0.00
GRAND TOTAL USD	19,320.00

TERMS AND CONDITIONS

-

All Quotations/Sale Orders and subsequent orders are subject to compliance to our standard terms & conditions unless stated otherwise.

- See Terms and Conditions of sale at <https://miatlantic.net/terms>

- No returns accepted without prior authorization. See Return Policy at <https://miatlantic.net/return-policy>

POPULAR BRANDS - WE DEAL WITH



Experience State of the Art Online Business REGISTER as customer at www.miatlantic.us

3728 Philips Hwy Ste 12
Jacksonville, Florida (FL) 32207
www.gtiguys.com
904-998-7555



Beach Community Development District
250 International Parkway 208
Lake Mary, FL, United States 32746

Invoice # 13010
Invoice Date 04-15-2026
Balance Due \$4,820.00

Item	Description	Unit Cost	Quantity	Line Total
Labor	Removal and replacement of 24x CCTV cameras around clubhouse and pool areas. Remove and replace 12x Access Points around clubhouse and pool areas. Configuration of new provided networking equipment with VLAN segregations. Network lines to be toned and labeled.	\$4,820.00	1.0	\$4,820.00

Invoice Message

Subtotal	\$4,820.00
Tax	\$0.00
Invoice Total	\$4,820.00
Payments	\$0.00
Credits	\$0.00
Balance Due	\$4,820.00

Disclaimer

I agree to release the above equipment to GTI Guys LLC DBA GTI Computers("GTI") for evaluation and/or repair. I agree that GTI is in no way responsible for the condition of the equipment prior to being serviced, or for lost or damaged data that may occur during the evaluation and/or repair . I agree that the above description of the equipment is based solely upon my representations and may be in error. I agree that GTI makes no representations, warranties or guarantees as to the length of time to make an evaluation on repairs, as to whether repairs can in fact be made, or as to the current or future impact any evaluation or repairs may have on existing or future hardware, software or external and peripheral devices that may be attached to the equipment(e.g., networks). I understand that the service fees are charged by the hour for time spent on and off the premises related to this Service Work Order. I understand GTI is not responsible for any equipment left at the store for over 30 days after check-in or 15 days after work is complete will be forfeited and/or recycled to recoup unpaid labor and customers will not be reimbursed for loss of equipment. I agree that GTI will not release the above equipment until all parts and/or labor charges have been paid in full. I agree that service fees are payable whether or not a problem is solved.

I have read this Service Work Order before signing and agree to its terms and conditions

Signed: _____

Date: _____



GTI Guys LLC

GTI Computers & Security

Scope of Work Agreement

Tamaya Community Clubhouse Network & CCTV Rehabilitation

Project Overview

GTI Guys LLC will perform a network and CCTV system rehabilitation at the Tamaya Community clubhouse. The project includes upgrading existing infrastructure using UniFi equipment while utilizing existing cabling.

Scope of Work

- Replace existing access points and CCTV cameras with UniFi equivalents at current locations.
- Install UniFi UDM Pro Max, UniFi NVR Pro, and (2) UniFi 48-Port PoE switches.
- Tone, trace, and label all existing cabling between endpoints and MDF/IDF locations.
- Configure UniFi system including VLANs and network segmentation.
- Integrate wireless bridge connectivity for remote cameras (tennis courts).
- Test and verify all systems for proper operation.

Cabling & Infrastructure

All existing cabling will be reused. GTI Guys LLC is not responsible for performance limitations or failures due to pre-existing conditions.

Additional Work & Modifications

This scope is based on existing device locations and infrastructure. Requests for relocation of devices or infrastructure modifications may require additional labor, materials, and construction. Such work will be addressed through an approved change order.

Project Conditions

Unforeseen Conditions: Hidden or unknown conditions may require additional work and will be handled via change order.

System Downtime: Temporary service interruptions may occur during installation and configuration. Efforts will be made to minimize disruption.

Payment Terms: Payment is due in full upon completion unless otherwise agreed in writing.

Change Orders: Work outside this scope requires written approval and may affect cost and timeline.

Pre-Existing Conditions: GTI Guys LLC is not responsible for existing infrastructure performance or deficiencies.

Acceptance

By signing below, both parties agree to the scope of work outlined above.

GTI Guys LLC (Contractor)	Beach CDD (Client)
Signature: _____	Signature: _____
Name: _____	Name: _____
Date: _____	Date: _____

EXHIBIT 12

ESTIMATE

C Buss Enterprises Inc
152 Lipizzan Trl
Saint Augustine, FL 32095-8512

clayton@cbussenterprises.com
+1 (904) 710-8161
www.cbussenterprises.com



Bill to
Tamaya/Beach CDD
12788 Meritage Blvd
Jacksonville, FL 32246

Estimate details
Estimate no.: 1749
Estimate date: 04/07/2026

PO: MAIN POOL

#	Product or service	Description	Qty	Rate	Amount
1.	POOL PARTS	[CPI-VFD-10HP-230V] 10Hp vfd 230V 10Hp 3-phase (5hp 1-Phase) VFD 230VAC Pre-Programmed and Tested	1	\$3,157.59	\$3,157.59
2.	LABOR	INSTALLATION/REPAIR LABOR, PER HOUR	2	\$150.00	\$300.00
				Total	\$3,457.59

Accepted date 4/7/2026

Accepted by D.C. MacLennan (2nd
Chair approval also)

EXHIBIT 13



Quote: 3009

Date: 04/06/26

Quote Expires: 04/21/26

1128 Carmona Place, St. Augustine, FL 32092

Telephone: (904) 315-3933; (904) 315-3944

PROJECT:
Dining Tables & Chairs

BILLING ADDRESS:
Beach CDD
250 International Parkway, Suite 208
Lake Mary, FL 32746

SHIPPING ADDRESS:
Tamaya Clubhouse
12788 Meritage Boulevard, Jacksonville, FL 32246

PAYMENT TERMS: 100% PAYMENT DUE AT TIME OF ORDER

DESCRIPTION	STYLE	SIZE	FABRIC / FRAME	UNIT \$	QTY.	TOTAL \$
48" Dining Table, Round, 2.5" x 2.5" Legs, Aluminum Frame, Poly Lumber Slats, Umbrella Hole	Aluminum Frame / Poly Lumber Slats / 2.5"x2.5" legs	48"Round	TBD / TBD	\$749.00	15	\$11,235.00
Discount				-\$37.45	15	-\$561.75
Dining Chair with Arms, Aluminum Frame, Poly Lumber Slats	Aluminum Frame / Poly Lumber Slats	Std.	TBD / TBD	\$576.00	80	\$46,080.00
Discount				-\$28.80	80	-\$2,304.00
42" Dining Table, Square, Aluminum Frame, Poly Lumber Slats, No Umbrella Hole	Aluminum Frame / Poly Lumber Slats	42" Square	TBD / TBD	\$609.00	5	\$3,045.00
Discount				-\$30.45	5	-\$152.25

Freight Includes: Yes/No	<p><i>Estimated Lead Time:10 - 12 Weeks.</i> <i>Payment is Required at Time of Order.</i> <i>Lead Time begins once payment has been recieved.</i> Southern Breeze will meet truck for delivery, offload, unwrap, and set up all items on pool deck.</p>	Product Total	\$57,342.00
Call Prior to Delivery: Y		Freight	\$1,800.00
Lift Gate: N		TAX EXEMPT	\$0.00
Limited Access Delivery: N		TOTAL	\$59,142.00

TERMS & CONDITIONS: All sales are final and can not be cancelled, returned, or refunded. **A resale tax certificate or tax exemption certificate must be supplied at time of order.** If not received, sales tax will be applied. All orders are custom made to order & require 100% Payment Due at Time of Order. Checks should be made payable to Southern Breeze Outdoor Furnishings, LLC. All orders will be drop shipped to customer unless specified otherwise. **Additional freight and/or handling charges** may be applied, and not limited to, receipt services; residential, church, or school deliveries; lift gates; change in delivery address and/or rescheduling changes of delivery date, time, or location.

I agree to order specifications above, quantities, pricing, terms & conditions: Southern Breeze Outdoor Furnishings, LLC

/ *Chris Smith*

Purchaser's Signature / Printed Name Date Chris Smith - VP - Business Development

By signing below, I acknowledge that lead times and production do not begin until payment has been received.

Purchaser's Signature / Printed Name Date

EXHIBIT 14

TIP Use the ← and → arrows below to turn the page and learn more. ×



Proposal

Paver Repairs, (Front and Gym gates)

	NEW COLOR	#COATS
Paver Repair 3, (Front gate & gym gate) Repair standard pavers at entrance and exit of front gate as specified Repair standard pavers at new gate adjust to gym hallway as specified.	N/A	1
PAVER REPAIRS, (FRONT AND GYM GATES) SUBTOTAL		\$6,286.00
GRAND TOTAL		\$6,286.00

#32856276

**Beach CDD -
32856276 - Beach
CDD**

**360 Painting of
Jacksonville**

- Welcome
- About Us
- Insurance
- Proposal
- Agreement
- Certificate of Completion

EXHIBIT 15

Sales Quote**Sales Quote Number: 845302**

Page: 1

KaTom Restaurant Supply, Inc.
305 Katom Dr.
KODAK, TN 37764

Sales Quote Date: 3/19/2026	Due Date 3/19/2026	Ship Date 3/19/2026
Customer ID 1912945	Contact Oliver Ingram	SalesPerson Isabella Mills
Cust. Phone (904) 329-2277	Cust. Fax	Quote Expires: 3/24/2026
oingram@vestapropertyservices.com		

Sell

To: Vesta Property Services
 Oliver Ingram
 17288 Meritage Blvd
 JACKSONVILLE, FL 32246
 USA

Ship

To: Vesta Property Services
 Oliver Ingram
 17288 Meritage Blvd
 JACKSONVILLE, FL 32246
 USA

Terms CREDIT CARD	Ext Doc No.	Your Reference	Ship Via	Loc Code KODAK	Loc Phone	Loc Fax
-----------------------------	--------------------	-----------------------	-----------------	--------------------------	------------------	----------------

Blueprint

No.	Number	Description	Qty	Unit	Unit Price	Total Price
	608-DEV500SG30LP	DEV500SG-30-LP ICE-DEVICE 460LB W/25LB TOTE LOW PROFILE	1	EA	4,498.58	4,498.58
		Free Shipping to Customer				
	608-00917054	Must Ship LTL 00917054 CORRECTIONAL PACKAGE (NO WINDOW) LOWER	1	EA	1,742.25	1,742.25
	399-AR10000P	AR-10000-P ARCTIC PURE PLUS PRIMARY WATER FILTER ASSY	1	EA	240.65	240.65
	399-IDT0420A161	IDP0420A 161 ICE MAKER AIR DICE 463LB 22" ES 115/1	1	EA	3,583.27	3,583.27
		Item Ships in 1-3 Business Days from Vendor				
		Free Shipping to Customer				
		Must Ship LTL				

Sales Quote

Sales Quote Number: 845302

Page: 2

**KaTom Restaurant Supply, Inc.
305 Katom Dr.
KODAK, TN 37764**

Sales Quote Date: 3/19/2026	Due Date 3/19/2026	Ship Date 3/19/2026
Customer ID 1912945	Contact Oliver Ingram	SalesPerson Isabella Mills
Cust. Phone (904) 329-2277	Cust. Fax	Quote Expires: 3/24/2026
oingram@vestapropertyservices.com		

Sell
To: Vesta Property Services
 Oliver Ingram
 17288 Meritage Blvd
 JACKSONVILLE, FL 32246
 USA

Ship
To: Vesta Property Services
 Oliver Ingram
 17288 Meritage Blvd
 JACKSONVILLE, FL 32246
 USA

Terms CREDIT CARD	Ext Doc No.	Your Reference	Ship Via	Loc Code KODAK	Loc Phone	Loc Fax
-----------------------------	--------------------	-----------------------	-----------------	--------------------------	------------------	----------------

Blueprint
No. Number Description Qty Unit Unit Price Total Price

Website: katom.com **Phone:** (800) 541-8683 **Fax:** (800) 821-9130

This office will follow up with you within 24 hours to ensure you received this quotation. Quotation must be signed below to be official.

Submitted by: _____ **Accepted by:** _____

Subtotal: 10064.75
 S, H, & I: 55.00
 Total Sales Tax: 986.68
 Total: 11106.43

Federal and/or State tax laws may apply at the time of invoicing.

BY PLACING YOUR ORDER, YOU ACKNOWLEDGE AND AGREE THAT YOU HAVE READ AND AGREE TO BE BOUND BY KATOM'S POLICIES AND PROCEDURES STANDARD TERMS AND CONDITIONS, POLICIES AND PROCEDURES, INCLUDING BUT NOT LIMITED TO THE KATOM PRIVACY POLICY, RETURN POLICY, SHIPPING POLICY, AND TERMS AND CONDITIONS (WHICH INCLUDE DISCLAIMERS AND LIMITATIONS OF KATOM'S LIABILITY, AS WELL AS A PROVISION WHEREBY YOU AGREE TO ARBITRATE ALL DISPUTES), LOCATED AT WWW.KATOM.COM/POLICY (COLLECTIVELY, THE "TERMS"). PLEASE CALL 1-800-541-8683 TO OBTAIN A PHYSICAL OR E-MAIL COPY OF THE TERMS. THE TERMS ARE ALSO AVAILABLE BY SCANNING THE QR CODE IN THE BOTTOM RIGHTHAND CORNER OF THIS QUOTE WITH THE CAMERA OF YOUR MOBILE DEVICE. IF YOU DO NOT AGREE TO BE BOUND BY ALL PROVISIONS OF THE TERMS, YOU MUST NOTIFY KATOM WITHIN TEN (10) DAYS OF RECEIPT OF THIS QUOTE AND IMMEDIATELY REJECT AND RETURN ALL GOODS TO KATOM. YOUR USE OF THE GOODS, OR YOUR FAILURE TO REJECT AND RETURN THE GOODS TO KATOM WITHIN TEN (10) DAYS, SHALL CONSTITUTE ACCEPTANCE OF ALL TERMS.



iT0420 Ice Cube Machine

Models

- IDT0420A
 IYT0420A
 IDT0420W
 IYT0420W



Indigo NXT Series iT420 Ice Machine on D320 Bin
*Ice Machine and Bin sold separately

Designed for operators who know that ice is critical to their business, the Indigo NXT Series ice machine's preventative diagnostics continually monitor itself for reliable ice production. Improvements in cleanability and programmability make your ice machine easy to own and less expensive to operate.

- **New levels of Performance** – Showcasing an average of 41% lower energy consumption, 21% reduction in in potable water usage and a 34% reduction in condenser water usage. This translates into lower cost of ownership over the life of your machine.
- **easyTouch® Display** - New icon based touch screen takes the guess work out of owning and operating an ice machine.
- **Programmable Ice Production** – Now its super easy to program your ice machine to be off at certain times of the day to save money with fluctuating electrical rates. Also programmable by daily ice production volume and night time programming.
- **Easy to Clean Foodzone** – Hinge front door swing out for easy access. Removable water-trough, distribution tube, curtain, water probe and water pump for fast and efficient cleaning. Selected components are made with AlphaSan® antimicrobial.
- **Intelligent Diagnostics** – Provides 24 hour preventative maintenance and diagnostic feedback for trouble free operation.
- **Acoustical Ice Sensing Probe** – Unique patented technology allows for reliable operation in challenging water conditions and environments
- **DuraTech® Exterior** – Provides superior corrosion resistant above stainless steel. Innovative clear-coat resists fingerprints and dirt making it easier to keep clean.
- Available **LuminIce® II Virus and Bacteria Inhibitor** – Controls viruses, bacteria, mold, and yeast within the food zone to keep the ice machine clean longer. A new sanitation icon lets you know the operational status.
- **Active Sense** – insures consistent ice harvest in all environmental conditions. This software works in conjunction with the acoustical ice sensing probe improving reliability and performance

Ice Machine Electric

115/60/1 standard
(208-230/60/1 also available)

Minimum circuit ampacity:

Air-cooled: 11.3, 115v, 5.5 208-230v
Water-cooled: 10.6, 115v, 5.2 -208-230v

Maximum fuse size:

Air-cooled: 15 1ph
Water-cooled: 15 1ph

Specifications

BTU Per Hour:
3,800 (average),
and 6,000 (peak)

Refrigerant:

R410A CFS - Free
Lowers global warming
by 48% 51.1 kPA)

Operating Limits:

- Ambient Temperature Range:
40 to 110 F (4.4 to 43.3 C)
Water Temperature Range:
40 to 90 F (4.4 to 32.2 C)
- Potable Water Pressure:
Min. 20 psi (137.9 kPa)
Max. 80 psi (551.1 kPa)
- Condenser Water Pressure:
Min. 20 psi (137.9 kPa)
Max. 276 psi (1902.95 kPa)



Ice Shape



Half Dice
3/8" x 1 1/8" x 7/8"
(.95 x 2.86 x 2.22 cm)



Dice
7/8" x 7/8" x 7/8"
(2.22 x 2.22 x 2.22 cm)





iT0420 on D-320 Storage Bin

- (A) Electrical Entrance (2) Options
- (B) 3/8" (0.95 cm) F.P.T. Water Condenser Inlet (water-cooled units)
- (C) 1/2" (1.27 cm) F.P.T. Water Condenser Outlet (water-cooled units)
- (D) 1/2" (1.27 cm) Auxillary Base Drain Socket
- (E) 3/8" (0.95 cm) F.P.T. Ice Making Water Inlet
- (F) 1/2" (1.27 cm) F.P.T. Ice Making Water Drain
- (G) 3/4" (1.91 cm) Bin Drain

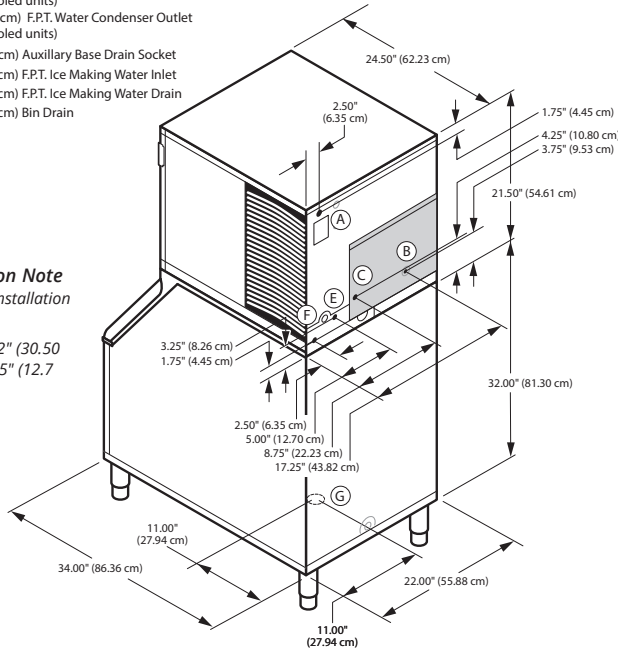

Installation Note
Minimum installation clearance:
Top/side: 12" (30.50 cm)
Back is 5" (12.7 cm)

Space-Saving Design



	iT0420 D-320	iT0420 D-420
Height	59.50" 151.13 cm	71.50" 181.61 cm
Width	22.00" 55.88 cm	22.00" 55.88 cm
Depth	34.00" 86.30 cm	34.00" 86.30 cm
Bin	264 lbs.	383 lbs.
Storage	118 kgs.	174 kgs.

Height includes adjustable bin legs 6.00" to 8.00", (15.24 to 20.32 cm) set at 6.00" (15.24 cm).
Bin capacity is based on 90% of the volume x 33 lbs/ft³ average density of ice.

Specifications

	Model	Ice Shape	Ice Production 24 Hours		Power Usage kWh/100 lbs. @90°Air/70°F	Potable Water Usage/100 lbs. 45.4 kgs. of Ice
			70°Air/ 50°F Water	90°Air/ 70°F Water		
AIR COOLED	IDT0420A	dice	470 lbs.	375 lbs.	5.6 ★	19.9 Gal. 73.3 L
			213 kgs	170 kgs		
	IYT0420A	half-dice	460 lbs.	375 lbs.	5.55 ★	19.9 Gal. 73.3 L
			209 kgs	170 kgs		
WATER COOLED	IDT0420W	dice	454 lbs.	400 lbs.	4.28	19.9 Gal. 73.3 L
			206 kgs	181 kgs		
	IYT0420W	half-dice	490 lbs.	425 lbs.	4.24	19.9 Gal. 73.3 L
			222 kgs.	193 kgs		

* Water-cooled Condenser Water Usage / 100 lbs. /45.4 kgs. Of Ice: 140 gal/ 530 L.
*Water-cooled models are excluded from ENERGY STAR qualification.

Order separately: Ice storage bin for all units
★ ENERGY STAR® 3.0 qualified

Accessories

LuminIce® II Virus and Bacteria Inhibitor
controls viruses and bacteria in the ice machine.



External Scoop holder
protect the ice scoop with the NSF approved versatile scoop holder.



Arctic Pure® Plus
reduce sediments and chlorine contaminants down to .5 microns. Use with Pre-filter recommended.



iAuCS®
schedules and performs routine ice machine cleaning automatically.



Manitowoc Ice reserves the right to make changes to the design or specifications without prior notice.

Single door Ice•Device™

low-profile with Totes™ ice carrier



DEV1010SG-48-LP shown

Features

Designed with speed, safety and sanitation in mind

- elevated ice storage bin uses gravity to dispense ice through a chute seven times faster than scooping
- dispensing into a Totes ice carrier eliminates scooping by hand to help prevent cross-contamination
- industry exclusive SmartGATE® ice shield controls the flow of ice to reduce spill and limit contact with ice
- locks in three positions and returns easily to full down position

Fresher ice

- first ice in is first ice out

Ice compatibility

- compatible with most non-flake ice types, including customer preferred Chewblet® ice and cube ice

Durable, user-friendly construction

- full stainless bin exterior and 10.00" (2.54 cm) flanged legs
- corrosion-resistant poly bin liner and ABS top
- heavy duty "stay-open" PowerHinge™ door hinge – easy one hand open and close without door catches

Rugged poly Totes ice carrier

- limits lifted weight to 25 lb (11 kg) for safe ice delivery
- rectangular design facilitates pouring into beverage dispensers, wait stations and ice wells

Easy installation

- comes with ice access door assembly attached to body of bin
- only 31.00" (78.7 cm) wide to fit through standard door openings by removing front door assembly (4 screws, no sealant)
- drain elbow with 1.00" (2.54 cm) barb fitting provided

Warranty

- parts and labor for corrosion repair for useful life of product
- 5 years parts and labor on all other integral components
- 3rd party ice machines must be installed and operated in accordance with the manufacturer's instructions
- visit follettice.com for complete warranty details

Includes:

- custom-cut non-corroding ABS top
- optional Flexi-Top™ ice bin top system for 48.00" (121.9 cm) and 60.00" (152.4 cm) wide models – allows many ice machines to fit one top
- single Totes ice carrier
- 82 oz (2.4 L) plastic ice scoop
- paddle and rake tool set with hanging bracket

Accessories

Additional accessories (refer to form# 3435)

Specification

Maximum bin capacity ¹	see model table below
W1 Bin width	see model table below
D1 Bin depth	31.00" (78.7 cm)
Bin depth with lower door assembly ²	39.00" (99.1 cm)
Bin depth with door fully extended	49.50" (125.7 cm)
H1 Bin height with legs ³	see model table below
Required door access ⁴	32.00" (81.3 cm)
W2 Tote width	39.7 cm (15.62")
D2 Tote depth	18.08 cm (7.12")
H2 Tote height	38.1 cm (15.00")
L1 Drain ⁵	1.00" FPT, center of bin bottom (drain elbow supplied)
Dispense rate	up to 5 lb (2.3 kg) per second
Ice compatibility	cube ice and Chewblet ice
Approximate ship weight	see model table below

NOTE: For indoor use only

SHORT FORM SPECIFICATION: Ice•Devlce system to be Follett model _____ elevated bin, 10.00" (25.4 cm) flanged legs and Totes ice carrier with front ice chute and industry-exclusive SmartGATE ice shield. Bin to hold approximately _____ lb (kg) of ice. Exterior finish of bin to be full stainless front, sides, back and bottom. Bin liner to have non-corroding polyethylene walls and stainless steel bottom. Bin insulation to be CARB compliant non-HFC foam, bonded to shell and liner for added structural strength. Bin top to be ABS and custom-cut for ice machine(s) to be used. Lower door assembly to include non-corroding poly access door, poly lift door with PowerHinge to eliminate gasket and latches, and inner SmartGATE to positively control ice flow into access door area. Entire lower door assembly to be easily removable for installation through narrow doors. Upper inspection window (on all models except DEV500SG-30, DEV860SG-48 and DEV1080SG-30) to be double-wall poly to increase durability and minimize ice melt and condensation. Totes to be of one-piece, molded poly with swivel handle. All models to be equipped 82 oz (2.4 L) plastic ice scoop and paddle and rake tool set. NSF listed.

Dimensional drawing

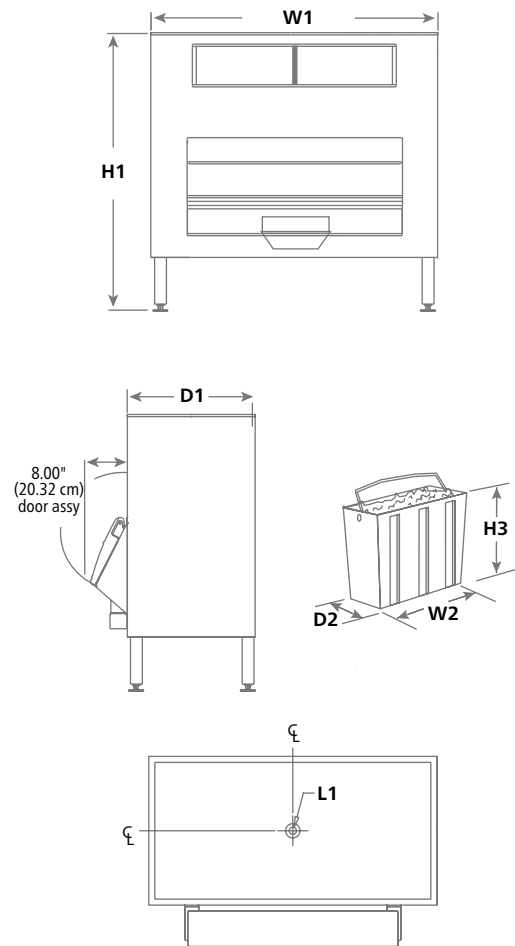

FLEXI-TOP, ICE•DEVlCE, POWERHINGE, SMARTCART and TOTES are trademarks of Follett Products, LLC. CHEWBLET, FOLLETT and SMARTGATE are registered trademarks of Follett Products, LLC, registered in the US. Follett reserves the right to change specifications at any time without obligation. Certifications may vary depending on country of origin.

Model	Maximum bin capacity lb (kg) ¹	Cubic volume cu ft (m)	Width - W1 in (cm)	Height with legs ³ - H1 in (cm)	Approximate ship weight lb (kg)
DEV500SG-30-LP ⁶	460 (209)	14.80 (0.41)	30.00 (76.2)	48.75 (123.8)	186 (85)
DEV700SG-30-LP	680 (309)	21.70 (0.61)	30.00 (76.2)	64.25 (163.2)	229 (104)
DEV860SG-48-LP ⁶	860 (391)	25.50 (0.72)	48.00 (121.9)	50.25 (127.6)	288 (131)
DEV1010SG-48-LP	1000 (454)	31.90 (0.90)	48.00 (121.9)	60.25 (153.0)	277 (126)
DEV1175SG-48-LP	1185 (538)	37.60 (1.06)	48.00 (121.9)	66.25 (168.3)	319 (145)
DEV1300SG-48-LP	1320 (599)	41.90 (1.19)	48.00 (121.9)	68.75 (174.6)	342 (156)
DEV1160SG-56-LP	1170 (531)	37.30 (1.06)	56.00 (142.2)	60.25 (153.0)	296 (135)
DEV1350SG-56-LP	1360 (617)	43.20 (1.22)	56.00 (142.2)	66.25 (168.3)	353 (161)
DEV1080SG-60-LP ⁶	1080 (490)	34.30 (0.97)	60.00 (152.4)	50.25 (127.6)	297 (135)
DEV1325SG-60-LP	1325 (602)	42.00 (1.19)	60.00 (152.4)	60.25 (153.0)	373 (170)
DEV1475SG-60-LP	1490 (676)	47.40 (1.34)	60.00 (152.4)	66.25 (168.3)	356 (162)
DEV1650SG-60-LP	1660 (754)	52.80 (1.50)	60.00 (152.4)	68.75 (174.6)	336 (153)

- Computed on cubic volume of bin. Does not reflect cart capacity or voids that can occur due to pyramiding.
- Lower door assembly easily removed for installation access.
- Special top required for ice machines weighing more than 1000 lb (454 kg). Add 0.5" (1.27 cm) to height. Contact factory.
Note: Not available for model DEV500 and DEV700.
- Required clearance for installation access through doors (may require removal of lower door assembly).
Note: DEV500 and DEV700 require 31.00" (78.7 cm) of clearance.
- Follett recommends installation of a floor drain with grate with all ice storage bins. Consider cart positioning when locating the drain.
Clearance required to pull cart from below bin — minimum 36.00" (91.4 cm), optimal 40.00" (101.6 cm).
- DEV500SG-30, DEV860SG-48 and DEV1080SG-60 do not have upper inspection window.

Single door Ice•Devlce, low-profile



EXHIBIT 16

BEACH COMMUNITY DEVELOPMENT DISTRICT

COMPREHENSIVE AMENITY FACILITY POLICIES

Effective Date: May 01, 2026

Removes and replaces all previous policies and enforcement practices.

District Manager:

Vesta District Services
250 International Parkway, Suite 208
Lake Mary, FL 32746

TABLE OF CONTENTS

I. DEFINITIONS AND GENERAL PROVISIONS 03

- Definitions
- Identification and Access Cards
- Non-Resident Annual User Fee
- Homeowners Association Use of Facilities
- Community Club Use of Facilities
- Guest Policies
- Renter's Privileges
- Instructor/Trainer Policies

II. GENERAL AMENITY FACILITY PROVISIONS 09

- General Facility Policies
- Hours of Operation
- Vehicle and Parking Policies
- Loss or Destruction of Property
- Service Animal Policy
- General Usage Guidelines

III. RESORT-STYLE POOL FACILITIES 14

- General Swimming Pool Rules
- Lap Pool Policies

- Waterslide Policies
- Pool Deck and Amenity Areas

IV. FITNESS CENTER AND WELLNESS FACILITIES 18

- General Fitness Center Policies
- Equipment Usage Guidelines
- Group Fitness Room Policies
- Personal Training Guidelines

V. TENNIS FACILITY OPERATIONS 21

- Tennis Court Usage Policies
- Court Reservation System
- Tennis Equipment and Maintenance
- Professional Court Standards

VI. BASKETBALL AND RECREATIONAL COURTS 23

- Basketball Court Policies
- Multi-Use Court Guidelines
- Youth Supervision Requirements
- Equipment Policies

VII. PLAYGROUND AND FAMILY AMENITIES 25

- Playground Safety Policies
- Age-Appropriate Usage
- Equipment Guidelines
- Family Recreation Areas

VIII. EVENT FACILITIES AND RENTAL POLICIES 26

- Tamaya Hall Rental Policies
- Event Lawn Usage
- Private Event Guidelines
- Catering and Service Policies

IX. NO FISHING POLICY 31

- Water Feature Restrictions
- Environmental Protections
- Permitted Activities

X. ENFORCEMENT AND DISCIPLINARY PROCEDURES 31

- Violation Categories
- Progressive Discipline Policy
- Appeal Procedures
- Suspension and Termination

XI. CONSENT TO VIDEO AND AUDIO MONITORING 34

XII. APPENDICES 34

- Emergency Procedures
- Contact Information
- Forms and Applications
- Facility Rental Rates

I. DEFINITIONS AND GENERAL PROVISIONS

DEFINITIONS

"Amenity Facility" – shall mean the properties and areas owned by the District, intended for recreational use and available for rent in certain circumstances, including, but not specifically limited to, the pools, tennis and basketball courts, playground, fitness center, group fitness room, banquet event hall and large event lawn, together with its appurtenant facilities and areas.

"Amenity Facility Policies" or "Policies" – shall mean these Comprehensive Amenity Facility Policies of Beach Community Development District, as amended from time to time.

"Basketball Facilities" – shall mean the basketball court that is a part of the District's Amenity Facility.

"Board of Supervisors" or "Board" – shall mean the Beach Community Development District's Board of Supervisors.

"Community Club" – shall mean a group of two (2) or more self-organized Residents, Renters and/or Non-Resident Members with a common hobby or recreational, social, service and/or cultural interest that has applied for and received such designation from the District's Board.

"Credit Card Convenience Fee" – shall mean a 3% fee added to any and all fees or rates adopted by the District to be paid by any Patron seeking to pay such fee or rate with a credit card.

"District" – shall mean the Beach Community Development District.

"District Manager" – shall mean the professional management company with which the District has contracted to provide management services to the District.

"Amenity Manager / Facility Manager" – shall mean the management company, including its employees, staff and agents, contracted by the District to manage the Amenity Facility.

"Fitness Center" – shall mean the fully equipped fitness facility including cardiovascular equipment, strength training equipment, free weights, and associated wellness amenities.

"Group Fitness Room" – shall mean the dedicated studio space for fitness classes, yoga, pilates, and other group wellness activities.

"Guest" – shall mean any individual who is 4 years of age or over and is invited to use the Amenity Facility. Guests must be accompanied to use the Amenity Facility by a Resident, Non-Resident Member, or Renter. Refer to the maximum number of guests allowed per Amenity for maximum number of guests allowed on any given day.

"Homeowners Association" – shall mean the Tamaya Residential Homeowners' Association, Inc.

"Identification" – shall mean an acceptable photo identification card, which indicates a birthdate and an address. A valid student identification card may be used for a person under 18 years of age. The card may be on an electronic device, such as a picture on phone, but must be available upon request by the Amenity Manager / Facility Manager.

"Instructor" and "Trainer" – shall mean any person providing instruction or training to a non-family member, or more than one household, regardless of payment for such services. This term does not apply to the instruction or training of any person, or group of people, lasting less than ten minutes during a forty-eight (48) hour period of time.

"Non-Resident" – shall mean any person or persons who do not own or rent property within the District.

"Non-Resident Annual User Fee" – shall mean the fee established by the District for any person who is not a Resident or Renter and wishes to become a Non-Resident Member. The amount of the Annual User Fee is set forth herein, and that amount is subject to change based on Board action.

"Non-Resident Member" – shall mean any individual not owning or renting property in the District who is paying the Non-Resident Annual User Fee to the District for use of the Amenity Facility.

"Patron" or "Patrons" – shall mean Residents, Non-Resident Members, and Renters who are eighteen (18) years of age and older.

"Pool Complex" – shall mean the resort-style swimming pool complex including the main pool, lap pool, waterslide, spa, and associated deck areas.

"Renter" – shall mean any tenant residing in a Resident's home pursuant to a valid rental or lease agreement, or any person who rents certain portions or spaces of the Amenity Facility for specified events pursuant to the approval of the District staff.

"Resident" – shall mean any person, spouse or registered domestic partner of a person or family owning property within the Beach Community Development District.

"Swimming Pools and Waterslide" – shall mean the swimming pools and the waterslide that are part of the District's pool complex.

"Tamaya Hall" – shall mean the premier event facility available for private rentals and community programming.

"Tennis Facilities" – shall mean those tennis courts that are a part of the District's Amenity Facility.

IDENTIFICATION AND ACCESS CARDS

1. **Access Card Issuance:** Two (2) access cards will be issued to each household. There is a charge to replace a lost or stolen card as determined by the Board of Supervisors.
2. **Liability Waiver Requirement:** A Patron will be required to sign a waiver of liability before using the District amenities and will be held responsible for any loss or damage if the waiver is not signed before use of the amenities. Each Patron assumes sole responsibility for his or her property.
3. **Identification Verification:** Patrons shall be required to present Identification and Access cards upon request by staff at the Amenity Facility. This requirement ensures proper facility usage and maintains security standards.
4. **Card Security:** All lost or stolen Access cards must be reported immediately to the Amenity Manager's office. A fee will be assessed for any replacement cards as set forth herein. Any damage to District property as a result of a stolen or lost card may be the responsibility of the Resident, if not reported to the Amenity Manager's office within 24 hours of the loss being discovered.

NON-RESIDENT ANNUAL USER FEE

The Non-Resident Annual User Fee for any person not owning or renting real property within the District is **\$3,500**, and this fee shall include privileges for up to 2 adults and anyone under the age of 18 residing in the household. This payment must be paid in full at the time of completion of the Non-Resident application and the corresponding agreement.

This fee will cover membership to the Amenity Facility for one (1) fiscal year, October 1st through September 30th of following year, prorated if applicable. Each subsequent annual membership fee shall be paid in full by October 1st. Such fee may be increased by action of the Board of Supervisors. This membership is not available for commercial purposes.

HOMEOWNERS ASSOCIATION USE OF FACILITIES

1. **Fee Waiver:** Each Homeowners Association within the Beach CDD may use the Amenity Facility without being required to pay an Annual User Fee and/or a room rental fee. The District may limit or terminate a Homeowners Association's use of the Amenity Facility at any time.
2. **Damage Responsibility:** Any Homeowners Association that uses the Amenity Facility shall be responsible for the cost of cleaning and/or repairing any damage to the Amenity Facility occurring during Homeowners' Association events.

COMMUNITY CLUB USE OF FACILITIES

1. **Approval Process:** Each Community Club must fill out a form for approval to be considered as a club before they can use the Amenity Facility. Once approved, the Community Club may use the Amenity Facility for a function without being required to pay an Annual User Fee and/or a room rental fee. However, the District may limit or terminate a Community Club's use of the Amenity Facility at any time, including but not limited to circumstances in which the Community Club proposes to host an event or function in which the primary attendance at such event or function is not Residents, Renters and/or Non-Resident Members.
2. **Damage Responsibility:** Any Community Club that uses the Amenity Facility shall be responsible for the cost of cleaning and/or repairing any damage to the Amenity Facility occurring during the Community Club's events.
3. **Status Revocation:** The Board may revoke an organization's status under these policies as a Community Club at any time.

GUEST POLICIES

1. **Guest Responsibility:** Residents, Non-Resident Members, and Renters are responsible for all actions taken by their Guest. Violation by a Guest of any of these Policies as set forth by the District could result in loss of the privileges and/or membership of that

Resident, Non-Resident Member or Renter. Guests using any amenities must be accompanied by a Patron at all times.

2. **Age Restrictions:** Residents, Non-Resident Members, or Renters under the age of 18 may not invite guests to use the amenity facilities.
3. **Instruction Prohibition:** Guests are not allowed to receive training/instruction for any amenities within the District.

RENTER'S PRIVILEGES

1. **Designation Rights:** Residents who rent or lease out their residential unit(s) in the District shall have the right to designate the Renter of their residential unit(s) as the beneficial users of the Resident's membership privileges for purposes of Amenity Facility use.
2. **Equal Rights:** A Renter who is designated as the beneficial user of the Resident's membership shall be entitled to the same rights and privileges to use the Amenity Facility as the Resident. Renter's privileges shall only be in effect for the duration of the Rental Agreement for the residential unit.
3. **Mutual Exclusivity:** During the period when a Renter is designated as the beneficial user of the membership, the Resident shall not be entitled to use the Amenity Facility with respect to that membership.
4. **Financial Responsibility:** Residents shall be responsible for all charges incurred by their Renters which remain unpaid after the customary billing and collection procedure established by the District. Residents are responsible for the department of their respective Renter.
5. **Policy Compliance:** Renters shall be subject to rules and regulations as the Board may adopt from time to time.

INSTRUCTOR / TRAINER POLICIES

Application and Approval Process

a. Instructor Approval: An Instructor / Trainer must be approved by the Amenity Manager. A list of approved Instructors will be kept in the Amenity Manager's office and will be posted on the District website. Instructors must re-apply annually.

b. Definition of Instruction: Instruction means any activity where one person provides targeted guidance, feedback, demonstrations, or structured practice to another person for the purpose of improving their skills. While casual play or practice between residents and guests is encouraged, even if occasional tips or advice are exchanged, structured lessons, drills, or

practice sessions designed to enhance skills constitute "instruction" and are prohibited. This policy does not apply to family members who provide instruction to each other.

Required Documentation

c. Application Requirements: The following must be completed or provided by an Instructor/Trainer applicant prior to approval:

- Certificate of Insurance (COI)
- Waiver of Liability (e.g. Hold Harmless Agreement) signed by each student receiving instruction. A parent or legal guardian must sign a Waiver of Liability for each student under 18 years of age.
- Successfully pass a criminal background check, paid for by the applicant.

Operating Requirements

d. Guest Restrictions: Instructors / Trainers are not allowed to invite Non-Resident / Guests to receive Instruction / Training.

e. Reporting Requirements: Instructors / Trainers will provide a weekly list of trainees and their addresses that were trained during the week prior, to the Amenity Manager.

f. Revenue Sharing: A 10% revenue sharing is required of District-approved instructors/trainers. This is to be paid to the Amenity Manager monthly and put into the general fund of the community. Instructors/trainers who fail to keep current on paying their stipends will be removed from the list of approved District instructors/trainers.

Policy Compliance

g. Facility Rules: Instructors / Trainers shall abide by the District's Amenity Facility Policies while using an Amenity.

h. Privilege Suspension: Instructors / Trainers not following these policies may have their access to the Amenity privileges suspended.

i. Compliance Maintenance: Instructors / Trainers must keep compliance up to date.

Tennis Instruction

Tennis Instruction: Instructors / Trainers for tennis require explicit approval by the Board.

II. GENERAL AMENITY FACILITY PROVISIONS

GENERAL FACILITY POLICIES

1. **Policy Amendment Authority:** The Board reserves the right to amend, modify, or delete, in part or in their entirety, these Policies at a duly noticed Board meeting. However, in order to change or modify rates or fees beyond any increases that may be specifically allowed for by the District's rules and regulations, the Board must hold a duly noticed public hearing on said rates and fees.
2. **Identification Requirements:** All users of amenities must present their Identification and Access cards upon request by staff at any Amenity Facility. Each Amenity has different minimum age requirements, please refer to specific Amenity sections to determine minimum age allowed.
3. **Hours of Operation:** All hours of operation, including holiday schedules, of the Amenity Facility will be established by the Board upon consultation with the Facility Manager.

HOURS OF OPERATION

Tamaya Hall Hours: Tuesday-Thursday: 10:00 am - 6:00 pm; Friday-Saturday: 12:00 pm - 6:00 pm; Sunday: 1:00 pm - 5:00 pm; Closed on Monday

Tennis Court Hours: 7:00 am - 10:00 pm

Fitness Center: 4:00 am - 10:00 pm

Pool Deck (Fenced Pool Area): Sunrise - 10:00 pm

Pools: SWIM AT YOUR OWN RISK. Swimming permitted Dawn to Dusk (30 minutes after sunrise until 30 minutes before sunset)

Waterslide: (Seasonal Hours, Memorial Day - Labor Day) Tuesday-Friday: 12:00 pm - 7:00 pm; Saturday-Sunday: 10:00 pm - 7:00 pm. Monday of Memorial Day, July 04, and Labor Day: 10:00 am - 7:00 pm.

Basketball: Sunrise-Sunset

VEHICLE AND PARKING POLICIES

4. **Parking Requirements:** Vehicles and golf carts operated by a resident, non-resident member or a renter, must be parked in designated areas. Vehicles should not be parked on grass lawns, in any way which blocks the normal flow of traffic or in any way that limits the ability of emergency service workers to respond to situations. Vehicles should not be parked on CDD common grassy areas throughout the community (e.g. pocket

parks and other common grassy areas). Vehicles cannot block the normal flow of traffic in any way that limits the ability of emergency service workers to respond to situations.

5. **Fireworks Prohibition:** Fireworks of any kind are not permitted anywhere at or in the Amenity Facility or adjacent areas; however, notwithstanding this general prohibition, the Board may approve the use of fireworks over a body of water.
6. **Service Area Restrictions:** Only District employees, District contractors or employees of the Facility Manager are allowed in the service areas of the Amenity Facility.

ADMINISTRATIVE AUTHORITY

7. **Enforcement Authority:** The Board of Supervisors (as an entity), the Amenity Manager and its staff shall have full authority to enforce these policies. However, the Amenity Manager shall have the authority to waive strict application of any of these Policies when prudent, necessary, or in the best interest of the District and its Residents. Such a temporary waiver of any policy by the Amenity Manager shall not constitute a continuous, ongoing waiver of said policy, and the Amenity Manager reserves the right to enforce all of these policies at any time he or she sees fit.

FACILITY SAFETY AND CONDUCT

8. **Safety Restrictions:** No climbing over or swinging on ladders, fences, or railings is allowed.
9. **Staff Courtesy:** Residents and Guests of all ages shall treat all staff members with courtesy and respect.
10. **Prohibited Vehicles:** Off-road motorbikes/vehicles are prohibited on all property owned, maintained and operated by the District including, but not limited to, the Amenity Facility.
11. **Skateboard Policy:** Skateboarding is not allowed on the Amenity Facility property at any time.
12. **Indoor Vehicle Policy:** Bicycles, scooters, and skateboards are not permitted inside any Amenity Facility building (e.g. Tamaya Hall, Fitness Center, Group Exercise Room, and Amenity Center Breezeway) or on the pool deck at any time.

COMMERCIAL AND ENTERTAINMENT POLICIES

13. **Entertainment Approval:** Performances at the Amenity Facility, including those by outside entertainers, must be approved in advance by the Amenity Manager.

14. **Advertisement Restrictions:** Commercial advertisements shall not be posted or circulated in the Amenity Facility. Petitions, posters or promotional material shall not be originated, solicited, circulated or posted on Amenity Facility property.
15. **Commercial Use Prohibition:** The Amenity Facility shall not be used for commercial purposes. The term "commercial purposes" shall mean those activities which involve, in any way, the provision of goods or services for compensation or advertising.
16. **Weapons Policy:** Firearms or any other weapons are prohibited in the Amenity Facility during any governmental meetings or functions, including those of the District, and as otherwise prohibited in the Amenity Facility in accordance with Florida law.

AMENITY MANAGER AUTHORITY

17. **Program Authorization:** The Amenity Manager reserves the right to authorize all programs and activities, including the number of participants, usage of equipment and supplies, facility reservations, etc., at the Amenity Facility, except usage and rental fees that have been established by the Board. The Amenity Manager also has the right to authorize management sponsored events and programs to better serve the Patrons, and to reserve any Amenity Facility for said events (if the schedule permits) and to collect revenue for those services provided.

GENERAL CONDUCT POLICIES

18. **Smoking Restrictions:** Smoking is not permitted at the Amenity Facility except within smoking areas designated by the Amenity Manager, if any.
19. **Policy Compliance:** Disregard for rules or policies or failure to follow instruction by Amenity Manager may result in expulsion from the Amenity Facility and/or loss of Amenity Facility privileges in accordance with the procedures set forth herein.
20. **Loitering Policy:** Loitering (the offense of standing idly or prowling in a place, at a time or in a manner not usual for law-abiding individuals, under circumstances that warrant a justifiable and reasonable alarm or immediate concern for the safety of persons or property in the vicinity) is not permitted at the Amenity Facility.
21. **Legal Compliance:** All Patrons and their guests shall abide by and comply with any and all federal, state and local laws and ordinances while present at or utilizing the Amenity Facility and shall ensure that any minor for whom they are responsible also complies with the same.
22. **Public Displays:** Public displays of affection which are inconsistent with the family-oriented nature of the Amenity Facility, are prohibited.

23. **Identification Requirement:** Any person using any District amenity shall have a District acceptable photo identification card, which indicates their birthday, with them at all times. A valid student identification card may be used for a person under 18 years of age. This policy does not apply to a minor when accompanied by a parent or legal guardian.

LOSS OR DESTRUCTION OF PROPERTY OR INSTANCES OF PERSONAL INJURY

1. **Personal Responsibility:** Each Patron and their Guest assumes sole responsibility for his or her property. The District and its contractors shall not be responsible for the loss or damage to any private property used or stored on or in the Amenity Facility.
2. **Liability for Damages:** Patrons and their guest shall be liable for any property damage and/or personal injury at the Amenity Facility, or at any activity or function operated, organized, arranged or sponsored by the District or its contractors, which is caused by the Patron or the Patron's family member(s). The District reserves the right to pursue any and all legal and equitable measures necessary to remedy any losses it suffers due to property damage or personal injury caused by a Patron or the Patron's family member(s).
3. **Hold Harmless Agreement:** Any Patron or other person who, in any manner, makes use of or accepts the use of any apparatus, appliance, facility, privilege or service whatsoever owned, leased, or operated by the District or its contractors, or who engages in any contest, game, function, exercise, competition or other activity operated, organized, arranged, or sponsored by the District, either on or off the Amenity Facility's premises, shall do so at his or her own risk, and shall hold the Amenity Facility's owners, the District, the Board of Supervisors, District employees, District representatives, District contractors, and District agents, harmless from any and all loss, cost, claim, injury, damage or liability sustained or incurred by him or her, resulting therefrom and/or from any act of omission of the District, or its respective operators, supervisors, employees, representatives, contractors or agents.

SERVICE ANIMAL POLICY

Dogs and all other pets (with the exception of a Service Animal as defined herein and complying with section 413.08(1)(d), Florida Statutes) are not permitted within any District-owned public accommodations including, but not limited to, the Amenity Facility. In the event a special event is held, as previously approved by the Board, and dogs are permitted at the Amenity Facility as part of the special event, they must be leashed. Owners are responsible for picking up after all pets as a courtesy to residents. All such animals must be in compliance with all current ordinances of the City of Jacksonville. It is the owners' responsibility to ensure that all dogs, including Service Animals, are healthy, vaccinated and collared with identification.

Service Animal Requirements

1. **Work and Task Requirements:** The work done or tasks performed must be directly related to the individual's disability and may include, but are not limited to, guiding an individual who is visually impaired or blind, alerting an individual who is deaf or hard of hearing, pulling a wheelchair, assisting with mobility or balance, alerting and protecting an individual who is having a seizure, retrieving objects, alerting an individual to the presence of allergens, providing physical support and assistance with balance and stability to an individual with a mobility disability, helping an individual with a psychiatric or neurological disability by preventing or interrupting impulsive or destructive behaviors, reminding an individual with mental illness to take prescribed medications, calming an individual with posttraumatic stress disorder during an anxiety attack, or doing other specific work or performing other special tasks.
2. **Control Requirements:** A Service Animal must be under the control of its handler and must have a harness, leash, or other tether, unless either the handler is unable because of a disability to use a harness, leash, or other tether, or the use of a harness, leash, or other tether would interfere with the service animal's safe, effective performance of work or tasks, in which case the service animal must be otherwise under the handler's control by means of voice control, signals, or other effective means.
3. **Removal Conditions:** The District may exclude or remove from its premises a Service Animal if the Service Animal is out of control and its handler does not take effective action to control it, the Service Animal is not housebroken, or the Service Animal's behavior poses a direct threat to the health and safety of others. Allergies and fear of animals are not valid reasons for denying access or refusing service to an individual with a Service Animal.
4. **Misrepresentation Penalties:** A person who knowingly and willfully misrepresents herself or himself, through conduct or verbal or written notice, as using a Service Animal and being qualified to use a Service Animal or as a trainer of a Service Animal commits a misdemeanor of the second degree, punishable as provided in sections 775.082 or 775.083, Florida Statutes, and may be subject to expulsion from the District's premises and/or suspension or termination of Amenities privileges as described herein.

GENERAL BEACH CDD AMENITY FACILITY USAGE POLICY

All Patrons and their guest using the Amenity Facility are expected to conduct themselves in a responsible, courteous, and safe manner, in compliance with all District policies and rules governing the Amenity Facility. Violation of the District's Policies and/or misuse or destruction of Amenity Facility equipment may result in the suspension or termination of District Amenity Facility privileges with respect to the offending Patron or Guest in accordance with District Policies set forth herein.

1. **Hours:** The Amenity Facility is available for use by Patrons during normal operating hours to be established and posted by the District and Facility Manager.
2. **Emergencies:** After contacting 911 Emergency Services if required, all emergencies and injuries must be reported to the Amenity Manager and to the office of the District Manager.
3. **District Equipment:** Any Patron utilizing District equipment is responsible for said equipment. If, as a result of the use of the equipment it is damaged, missing pieces or is in worse condition than when it was when usage began, that Patron or their guest will be responsible to the District for any cost associated with repair or replacement of the equipment.

Important Notice: Persons using the Amenity Facilities do so at their own risk. Facility Manager's staff members are not present to provide personal training, exercise consultation or athletic instruction, unless otherwise noted, to Patrons. Persons interested in using the Amenity Facility are encouraged to consult with a physician prior to commencing a physical fitness program.

III. RESORT-STYLE POOL FACILITIES

GENERAL SWIMMING POOL RULES

NO LIFEGUARD ON DUTY – SWIM AT YOUR OWN RISK

INCLEMENT WEATHER / THUNDERSTORM – SWIM AT YOUR OWN RISK

The Beach Community pool facilities feature resort-style amenities including a main swimming pool, dedicated lap pool, waterslide, and spa area, all designed to provide a premium recreational experience.

A. Access and Supervision Requirements

1. **Identification and Guest Limits:** All users of amenities must present their Identification and Access cards upon request by staff at any Amenity Facility. At any given time, a Patron may allow up to four (4) Guests to the swimming pool per household (unless a greater number of guests has been approved by the Amenity Manager).
2. **Child Supervision:** Children under fifteen (15) years of age must be accompanied and supervised at all times by a Patron during usage of the pool facility. Parents are responsible for the conduct of their children.

B. Safety and Behavioral Rules

3. **Prohibited Activities:**

- Horseplay. No jumping, pushing, running, throwing any item or other horseplay is allowed in the pool, slide or on the pool deck area
 - Diving. Diving is prohibited
 - Rails/Ladders. No hanging on guard rails or jumping from the ladder
 - Structures. Swinging on ladders, fences, or railings is not permitted
 - Do not toss rocks, vegetation, or foreign material into the pool
4. **Equipment Restrictions:** Electronic devices used to play music or other forms of entertainment are not permitted unless they are personal units equipped with headphones or for scheduled activities such as water aerobics or group fitness classes.
5. **Operating Hours:** Swimming is permitted only during designated hours as posted at the pool, and such hours are subject to change at the discretion of Facility Manager. Everyone must adhere to swimming pool rules at all times.
6. **Health Requirements:** Showers are required before entering the pool.
7. **Container Restrictions:** Glass containers are prohibited.
8. **Diaper Policy:** Children under three (3) years of age, and those who are not reliably toilet trained, must wear swim diapers, as well as a swimsuit over the swim diaper, to reduce the health risks associated with human waste in the swimming pools/deck area.

C. Equipment and Personal Items

9. **Play Equipment:** Play equipment and recreational items, such as floats, rafts, snorkels, dive sticks, flotation devices, balls and pool toys must have staff approval. The Amenity Manager reserves the right to discontinue usage of such play equipment during times of peak or scheduled activity at the pool, or if the equipment causes a safety concern or annoyance to other users of the facility.
10. **Pool Availability:** Pool availability may be limited or rotated in order to facilitate maintenance of the facility. Depending upon usage, the pool may be closed for various periods of time to facilitate maintenance and to maintain health code regulations.
11. **Prohibited Items on Pool Deck:** The use of bicycles, skateboards, roller blades, scooters, and golf carts is not permitted on the pool deck area, or inside any Amenity Facility gates at any time. Pets (except service dogs) are not permitted inside the Amenity Facilities.

D. Programming and Activities

12. **Program Authorization:** The Amenity Manager reserves the right to authorize all programs and activities (including the number of participants, equipment and supplies usage, etc.) conducted at the pool, including swim lessons and aquatic/recreational programs.

E. Dress Code and Conduct

14. **Swim Attire:** Proper family-friendly swim attire must be worn in the pool (no cutoffs). Absolutely no footwear is permitted in the pool at any time.

15. **Prohibited Items:** Chewing gum is not permitted in the pool or on the pool deck area.

16. **Changing Areas:** The changing of diapers or clothes is not allowed poolside.

17. **Pool Pollution:** No one shall pollute the pool. Anyone who pollutes the pool will be liable for any costs incurred in treating and reopening the pool.

18. **Radio Controlled Items:** Radio controlled watercraft are not allowed in the pool or the pool area.

F. Facility Management

19. **Access Maintenance:** Pool entrances must be kept clear at all times.

20. **Furniture Policy:** Pool furniture is not to be removed from the pool area.

21. **Conduct Standards:**

- Loud, profane, or abusive language is prohibited
- Physical or verbal abuse will not be tolerated
- Parents are responsible for the supervision and conduct of their children

22. **Lost Items:** The District is not responsible for lost or stolen items.

23. **Chemical Effects:** Chemicals used in the pool/spa may affect certain hair or fabric colors. The District is not responsible for these effects.

G. Deck Area Policies

24. **Deck Rental:** The deck area may not be rented at any time; however, access may be limited at certain times for various District functions, as approved by the Board and/or Amenity Manager.

25. **Food and Beverage:** No food, glass, or beverages (except bottled water) in the pool or on the pool wet deck.

26. **Alcohol Policy:** Discreet alcohol (i.e., unobtrusive, unnoticeable) use allowed four feet from pool edge. Glass bottles or containers are not permitted.

H. Swimming Instruction Policy

27. **Instruction Prohibition:** No swimming instruction is permitted in Beach CDD pools except by individuals specifically authorized by the District. Nonresidents may not give nor receive swimming instruction in Beach CDD pools. Swimming instruction means any activity where one person provides targeted guidance, feedback, demonstrations, or structured practice to another person for the purpose of improving their swimming skills. While practice between residents and guests is encouraged, even if occasional tips or advice are exchanged, structured lessons, drills, or practice sessions designed to enhance a swimmer's skills constitute "swimming instruction" and are prohibited. This policy does not apply to family members providing swimming instruction to each other.

LAP POOL POLICIES

Dedicated Lap Swimming Facility

1. **Priority Usage:** Swimmers have priority on the use of the Lap Pool, for the purpose of swimming laps.
2. **Lane Courtesy:** If swimmers are present, you must clear the lane to avoid interference.
3. **Child Supervision:** Children under age of 15 must be accompanied and supervised by a patron at all times. Parents are responsible for the conduct of their children.

WATERSLIDE POLICIES

Seasonal Operation with Enhanced Safety Protocols

1. **Risk Assumption:** Any person who uses the waterslide does so solely at his or her own risk.
2. **Height Requirement:** Children less than forty-eight (48) inches tall are not permitted to ride the waterslide.
3. **Lifeguard Supervision:** Lifeguards will supervise waterslide activity when the waterslide is open, and any person who uses the waterslide must abide by the supervising lifeguard's instructions and directions regarding use of the waterslide.
4. **Operating Conditions:** The waterslide may only be used during hours when it is attended at the top and bottom of the waterslide when a lifeguard is on duty.
5. **Single User Policy:** Only one person may ride the waterslide at a time.

6. **Clothing Restrictions:** No shorts with snaps or rivets will be allowed on the slide.
 7. **Safety Position:** Arms and hands must be kept inside the waterslide at times. Users must slide feet first.
 8. **Prohibited Items:** No jewelry, flotation devices or casts may be worn while using the waterslide.
 9. **Health Restrictions:** For safety reasons, pregnant women and persons with health conditions or back problems should not ride the waterslide.
-

IV. FITNESS CENTER AND WELLNESS FACILITIES

FITNESS CENTER POLICIES

State-of-the-Art Fitness Experience

The Beach Community Fitness Center provides resort-quality fitness equipment and programming in a premium environment designed for all fitness levels. Persons using the Fitness Center do so at their own risk. Persons using the Fitness Center are encouraged to consult with a physician prior to commencing a fitness program.

A. Facility Access and Eligibility

1. **Age Requirements:**
 - No one under the age of twelve (12) is allowed in the fitness center at any time
 - Children under sixteen (16) years of age must be accompanied at all times by a Patron during usage of the Fitness Center
2. **Guest Policy:** A maximum of one guest is permitted per member and must be accompanied by a Patron at all times.
3. **Operating Hours:** The Fitness Center is available for use by Patrons and guests during the hours of 4:00am to 10:00pm.

B. Emergency Procedures

4. **Emergency Response:** For all emergencies, call 911 Emergency Services immediately. All emergencies and injuries must also be reported to Amenity Facility Staff.

C. General Fitness Center Policies

Dress Code and Attire

1. **Required Attire:** Appropriate clothing and footwear (covering the entire foot) must be worn at all times in the Fitness Center. Appropriate attire includes t-shirts, tank tops, shorts, leotards, and/or sweat suits. No swimsuits, sandals, or flip-flops are allowed.
2. **Family-Friendly Environment:** The fitness center is family friendly. The fitness center was not built for and is not intended for powerlifting or special heavy weight training that requires safety equipment not available at the fitness center.

Behavioral Standards

3. **Prohibited Behavior:** No horseplay, aggressive or boisterous behavior, or rough play is allowed in the fitness center.
4. **Equipment Purpose:** Equipment is for exercise only. Do not sit on equipment to browse the internet, watch videos, listen to audio, or text.
5. **Equipment Hygiene:** Each individual is responsible for wiping off all fitness equipment, using provided disinfectants, after each use.

Authorized Personnel

6. **Trainer Requirements:** Only approved Instructor / Trainers are permitted in the District Fitness Center. The approved Instructor / Trainer list will be in the Facility Manager's office.

Prohibited Items

7. **Chalk Policy:** Hand chalk is not permitted to be used in the Fitness Center.
8. **Electronic Devices:** Electronic devices used to play music or other forms of entertainment are not permitted unless they are personal units equipped with headphones. The use of mobile phone speakers for any purpose is prohibited.
9. **Personal Items:** No bags, gear, or jackets are permitted on the floor of the Fitness Center or on the fitness equipment. Use hooks or lockers provided by the Amenity Facility.

Equipment Usage

10. **Equipment Restrictions:** Fitness equipment may not be removed from the Fitness Center or brought to other rooms. Weights must remain in the designated free weights area. Weights are not to be taken into the adjacent Group Fitness Room unless approved by the Facility Manager.

11. **Time Limits:** Limit use of cardiovascular equipment to thirty (30) minutes and step aside between multiple sets on weight equipment if other people are waiting.
12. **Weight Management:** Limit use of dumbbells to one set at a time. Return weights to their proper location after use.
13. **Weight Handling:** Do not drop the weights. Free weights are not to be dropped and should be placed only on the floor or on equipment made specifically for storage of the weights and must be kept in designated area. The floor was not designed for power lifting; dropping the weights will damage the floor and machines.
14. **Program Priority:** Any fitness program operated, established and run by the Facility Manager may have priority over other users of the District fitness centers.

EQUIPMENT SHARING AND MACHINE POLICIES

Optimizing Facility Usage During Peak Hours (typically 6-9 am and 5-8 pm)

Time Limits on Equipment

1. **Cardiovascular Equipment:** 30-minute limit during peak hours.
2. **Weightlifting Stations:** 15-minute limit on squat racks, bench presses, and similar equipment if others are waiting.

Equipment Sharing Protocol

3. **Working In:** Do not monopolize any equipment. If performing sets with rest periods, members should allow others to "work in" during their breaks.
4. **Peak Hour Courtesy:** During high-traffic times, members are encouraged to limit extended conversations or phone use while on machines or with equipment.
5. **Equipment Hoarding:** Using multiple pieces of equipment simultaneously for circuit training during peak hours is discouraged unless pre-approved by gym staff.

FOOD AND BEVERAGE POLICIES

Nutrition and Hydration Guidelines

1. **Food Restrictions:** No food, including chewing gum, is permitted within the fitness center.
2. **Beverage Policy:** Beverages are permitted in the fitness center if contained in non-breakable containers with screw top or sealed lids. Alcoholic beverages are not permitted.

V. TENNIS FACILITY OPERATIONS

TENNIS FACILITY POLICIES

INCLEMENT WEATHER / THUNDERSTORM – PLAY AT YOUR OWN RISK

Professional Tennis Experience

The Beach Community tennis facilities feature professionally maintained courts providing an authentic tennis club experience for players of all skill levels. Persons using the Tennis Facility do so at their own risk. Persons interested in using the Tennis Facility are encouraged to consult with a physician prior to using the facility.

As a courtesy to other Patrons, we ask that all players please recognize and abide by these rules and guidelines. Remember, not only is tennis a lifetime sport, it is also a game of sportsmanship, proper etiquette and fair play.

A. Court Access and Eligibility

1. **Age Requirements:** Children under twelve (12) years of age must be accompanied at all times by a Patron, during use of the Tennis Facility. The limit is 4 players per court, one must be a Patron. One court per Household. Parents are not allowed to drop off children under 12 years of age without specific supervision by a Patron.
2. **Operating Hours:** The Tennis Facility shall be available from 7:00am until 10:00pm daily.
3. **Emergency Procedures:** For all emergencies, call 911 Emergency Services immediately. All emergencies and injuries must also be reported to Amenity Facility Staff.

B. Dress Code and Equipment

4. **Proper Attire:** Proper tennis shoes and attire, as determined by the Facility Manager, are required at all times while on the courts. Shirts must be worn at all times. No black-soled or open-toe shoes are permitted.

C. Court Reservation and Usage System

5. **Availability System:** The tennis courts are available on a "first come, first served" basis for Patrons. Each Patron and the Patron's guests are limited to the use of one (1) tennis court for one (1) hour when others are waiting.

Court Changeover Procedures

If you find it necessary to "bump" other players when it is your turn to play:

- a. Never attempt to enter someone else's court before your turn.
- b. Never enter the court or distract players while others are in the middle of a point or game.
- c. Wait outside the entrance gate and politely inform the players that it is your turn.
- d. Allow players to finish out one more point, and then begin the player changeover for the court.
- e. When others are waiting, only Patrons may "hold" a court, and only for no more than ten minutes and those ten minutes are included in the one-hour time limit to use the court (i.e., usage is limited to 50 minutes if the court is held for ten minutes).

Prohibited Activities

- f. No Tournaments are allowed.
- g. Instruction of tennis is not permitted without explicit approval by the Board.

D. Tennis Instruction Policy

Comprehensive Instruction Prohibition: No tennis instruction is permitted on Beach CDD courts except by individuals specifically authorized by the District. Nonresidents may not give nor receive tennis instruction on Beach CDD courts. Tennis instruction means any activity where one person provides targeted guidance, feedback, demonstrations, or structured practice to another person for the purpose of improving their tennis skills. This includes, but is not limited to, instruction on stroke production, footwork, strategy, and match play. While casual play or practice between residents and guests is encouraged, even if occasional tips or advice are exchanged, structured lessons, drills, or practice sessions designed to enhance a player's skills constitute "tennis instruction" and are prohibited. This policy does not apply to family members providing tennis instruction to each other.

E. General Court Policies

Court Etiquette and Conduct

1. **Tennis Etiquette:** Proper tennis etiquette shall be adhered to at all times. The use of profanity or disruptive behavior is prohibited.
2. **Court Usage:** Tennis Courts are to be used for Tennis only.
3. **Equipment Responsibility:** Persons using the Tennis Facility must supply their own equipment (rackets, balls, etc.).

Prohibited Items and Activities

4. **Prohibited Items:** The Tennis Facility is for the play of tennis only. Pets (with the exception of "Service Animals"), roller blades, bikes, skates, skateboards, and scooters are prohibited from the tennis facility.

5. **Beverage Policy:** Beverages are permitted at the Tennis Facility if contained in non-breakable containers with screw top or sealed lids. No alcoholic beverages, glass or other breakable items are permitted on the tennis courts.
6. **Furniture Restrictions:** No chairs other than those provided by the District are permitted on the tennis courts.
7. **Net Safety:** No jumping over nets.

Court Maintenance and Care

8. **Cleanup Responsibility:** Players must clean up after play. This includes "dead" balls, trash, cups, plastic bottles, etc. The goal is to show common courtesy by leaving the court ready for play for Patrons who follow you.
9. **Damage Reporting:** Court hazards or damages, such as popped line nails, need to be reported to the Amenity Manager for repair.
10. **Court Brushing:** Brush court after use is required.

VI. BASKETBALL AND RECREATIONAL COURTS

BASKETBALL FACILITY POLICIES

INCLEMENT WEATHER / THUNDERSTORM – PLAY AT YOUR OWN RISK

Full-Court Basketball Experience

The Beach Community basketball facilities provide a regulation-size court suitable for full games, half-court play, and recreational activities. Persons using the Basketball Facilities do so at their own risk. Persons interested in using the facilities are encouraged to consult with a physician prior to using the facilities.

A. Access and Safety Requirements

1. **Age Requirements:** Children under twelve (12) years of age must be accompanied at all times by a Patron, during use of the Basketball Facility.
2. **Capacity Limits:** The maximum number of people on the Basketball Court is 10. There is a limit of 4 Guests per Household at any time.
3. **Operating Hours:** The Basketball Facilities are available for use from sunrise until sunset. The facilities may not be used after dark.

4. **Emergency Procedures:** For all emergencies, call 911 Emergency Services immediately. All emergencies and injuries must also be reported to Amenity Facility Staff.

B. Dress Code and Equipment

5. **Proper Attire:** Proper athletic shoes and attire are required at all times while on the courts. Shirts must be worn. No black-soled or open-toe shoes are permitted.

C. Court Usage Guidelines

6. **Availability System:** The basketball courts are available on a "first come, first served" basis. Players are limited to the use of one (1) basketball half-court when others are waiting.

D. General Basketball Policies

Conduct Standards

- a. **Behavioral Requirements:** The use of profanity or disruptive behavior is prohibited.

Equipment Policies

- b. **Basketball Provision:** Persons using the Basketball Facilities must supply their own basketballs. Basketball, if available, may be obtained from the office.

Prohibited Items

- c. **Restricted Items:** The Basketball Facilities is for the play of basketball only. Pets (with the exception of "Service Animals"), roller blades, bikes, skates, skateboards, golf carts, vehicles, and scooters are prohibited from the basketball facility.

- d. **Beverage Policy:** Beverages are permitted at the Facilities if contained in non-breakable containers with screw top or sealed lids. No alcoholic beverages, glass or other breakable items are permitted on the basketball courts.

- e. **Furniture Restrictions:** No chairs other than those provided by the District are permitted on the courts.

Facility Maintenance

- f. **Cleanup Requirements:** The courts must be left clean after use. Pick up all trash, cups, plastic bottles, etc.

Basketball Instruction Policy

- g. **Instruction Prohibition:** No basketball instruction is permitted on Beach CDD courts except by individuals specifically authorized by the District. Nonresidents may not give nor receive basketball instruction on Beach CDD courts. Basketball instruction means any activity where

one person provides targeted guidance, feedback, demonstrations, or structured practice to another person for the purpose of improving their basketball skills. This includes, but is not limited to, instruction on shooting and passing production, footwork, strategy, and match play. While casual play or practice between residents and guests is encouraged, even if occasional tips or advice are exchanged, structured lessons, drills, or practice sessions designed to enhance a player's skills constitute "basketball instruction" and are prohibited. This policy does not apply to family members who provide basketball instruction to each other.

Special Events

h. Event Authorization: Patrons who would like to use the basketball courts for events such as organized games for birthday parties or other special events must speak with the Amenities Manager prior to the event for permission to hold such events on Beach CDD basketball courts. This may also require a waiver for the number of guests allowed on Beach CDD basketball courts.

VII. PLAYGROUND AND FAMILY AMENITIES

PLAYGROUND POLICIES

Safe Family Recreation Environment

The Beach Community playground facilities provide age-appropriate recreation equipment designed for safe family enjoyment with comprehensive safety protocols. Persons using the Playground Facility do so at their own risk.

Supervision and Safety Notice: Playground equipment manufacturers and safety organizations emphasize the importance of active supervision to ensure children's safety during play. Although Florida law does not impose specific requirements on parental supervision at playgrounds within state facilities, parents share a responsibility to ensure children's safety during play. While not legally mandated, it is strongly recommended that parents actively supervise their children at playgrounds to ensure their safety. Active supervision involves being present, attentive, and engaging with your child during play to prevent accidents and respond promptly to any incidents. Adhering to recommended supervision practices and being vigilant about playground conditions can help create a safer environment for all children.

The District provides a playground for Patrons to enjoy with their children. The following guidelines apply:

A. Safety Requirements

1. **Footwear Requirements:** Footwear is required. Loose clothing, especially with strings, is prohibited.

2. **Surface Material Protection:** Since mulch material is necessary for reducing fall impact and for good drainage, mulch must not be picked up, thrown, or kicked for any reason.

B. Food and Beverage Policies

3. **Beverage Policy:** Beverages are permitted if contained in non-breakable containers with screw top or sealed lids on the playground but not on playground equipment.
4. **Food Restrictions:** No food or gum permitted on the playground.

C. Prohibited Items and Activities

5. **Animal Policy:** No pets of any kind are permitted at the playground.
6. **Container Restrictions:** No glass containers are permitted at the playground.
7. **Safety Restrictions:** No jumping off from any climbing bar or platform.
8. **Conduct Standards:** Profanity, rough-housing, and disruptive behavior are prohibited.

D. Incident Reporting and Maintenance

9. **Damage/Injury Reporting:** If anything is wrong with the equipment or someone gets hurt, notify the District immediately.
10. **Cleanup Requirements:** The playground must be left clean after use. Pick up all trash, cups, plastic bottles, etc.

VIII. EVENT FACILITIES AND RENTAL POLICIES

EVENT LAWN POLICIES

Expansive Outdoor Event Space

Persons using the Event Lawn Facility do so at their own risk.

The District offers an Event Lawn. The following policies apply:

A. Usage Guidelines

1. **Availability:** The lawn is available for use by Patrons only on a "first come, first served" basis.

2. **Vehicle Restrictions:** No bicycles, scooters, skateboards, hover boards, golf carts (without prior approval by the Amenity Facility Manager), or other equipment or vehicles with wheels are permitted.
3. **Ground Markings:** Chalking or marking the lawn must be approved in advance, if at all, and proper marking materials must be used.
4. **Container Policy:** No glass containers or breakable objects of any kind are permitted on the lawn.
5. **Pet Policy:** Pets must be kept on leash, and Patrons must pick up and dispose of pet waste in appropriate receptacles.
6. **Equipment Responsibility:** Patrons are responsible for bringing their own equipment.
7. **Activity Restrictions:** Golfing is not permitted on the lawn.
8. **Instruction Policy:** Except as expressly authorized by the District, sports instruction for fees, or solicitation of sports instruction for fees, is prohibited.
9. **Cleanup Requirements:** The lawn must be left clean after use. Pick up all trash, cups, plastic bottles, etc.

GENERAL FACILITY RENTAL POLICY

Premier Event Facilities

Patrons may reserve for rental certain portions of the Amenity Facility for private events. Reservations may not be made more than four (4) months prior to the event or made less than two (2) weeks prior to the event; the Amenities Manager may grant exceptions to these timelines at his/her availability and discretion. A wedding and reception may be booked more than four (4) months prior to the event. In addition, each household may rent a portion of the Amenity Facility no more than six (6) times per calendar year.

Restricted Rental Dates

The Amenity Facility is unavailable for private events on Memorial Day Weekend, Labor Day Weekend or any other weekend on which a federal holiday falls on either a Monday or Friday (with exception of Martin Luther King Day, Washington's Birthday, Columbus Day and Veterans Day) as well as the following holidays/weekends:

- Easter Sunday
- Memorial Day
- 4th of July
- Labor Day

- Thanksgiving
- Christmas Eve
- Christmas Day
- New Year's Eve

A. Eligible Renters

Certain portions of the Amenity Facility may be rented by the following individuals/groups:

- Residents (includes both events held by the Resident and events sponsored by the Resident)
- Renters
- Non-Resident Members
- Homeowners Association
- Community Clubs

B. Available Facilities and Rental Rates

The following portions of the Amenity Facility are available for rental for functions for up to eight (8) hours (including set-up and post-event cleanup). The rental time is inclusive of set-up and clean-up time. Rental fees may be waived for community use. For private events, rental fees shall apply.

Reference APPENDIX D for Event Facility Rental Rates *(All rates subject to 3% Credit Card Convenience Fee)*

Large Event Lawn Special Conditions: The Large Event Lawn may be used by a Patron and no more than four guests without a rental contract. Usage of the Large Event Lawn by a patron with more than four guests requires a rental contract and is subject to the policies outlined. The Large Event Lawn may be rented for no longer than eight hours. Patrons using the Large Event Lawn shall be responsible for the costs of cleaning and/or repairing any adverse impacts to the lawn. Any failure to clean and/or repair the Large Event Lawn will result in the security deposit being used to pay for such cleaning and/or repair, and Patron shall be responsible for all amounts, if any, in excess of the security deposit. Patrons are encouraged to photograph the Large Event Lawn prior to and after rental to document any damages. Any use of the Large Event Lawn by more than 100 guests shall require the District's written approval.

Important Note: The Pool Areas of the Amenity Facility are not available for private rental and shall remain open to other Patrons and their guests during normal operating hours. The Patron renting any portion of the Amenity Facility shall be responsible for any and all damages and expenses arising from the event.

C. Reservation Procedures

Reservation Process: Staff will take reservations in advance for the Amenity Facility. Reservations are on a "first come, first served" basis and can be made only in person by filling

out a Facility Use Application. Reservations must be made at least two (2) weeks in advance to the Amenity Manager Staff; the Amenities Manager may grant exceptions to these timelines at his/her availability and discretion. Patrons interested in reserving a room must submit to the Amenity Manager Staff a completed Facility Use Application.

Reservation Hold Policy: Reservations will be held for fifteen (15) minutes past the scheduled start time before re-assigning the reservation time slot. There are no personal "standing" reservations allowed for the facilities listed in the reservation policy.

Cancellation Policy: If the renter wishes to cancel a reservation, the cancellation must be communicated to the Amenity Manager no later than two (2) weeks prior to the scheduled event to have the full rental fee and the full deposit returned. If the event is cancelled less than two (2) weeks prior to the event, only the rental fee, but none of the security deposit, will be returned.

D. Payment and Deposit Requirements

Payment Processing: At the time of submission, the Patron shall provide the rental fee referenced above and a deposit. Rental fees may be paid by check, money order, and made payable to Beach Community Development District. The Amenity Manager Staff will review the Facility Use Application on a case-by-case basis and has the authority to reasonably deny a request. Denial of a request may be appealed to the District's Board of Supervisors for consideration.

Documentation Requirements: At the time the reservation is made, two checks or money orders (no cash), one for the deposit and one for the room rental, both made out to District must be delivered to the Amenity Manager along with completed paperwork and insurances, if necessary. Each Patron renting the Amenities must sign and execute a Rental Agreement acceptable to the District. Regardless of whether the Rental Agreement is executed, the Patron is bound by the Rental Agreement, which is incorporated herein by this reference.

E. Deposit Return Requirements

Deposit Security: Payment of the deposit and rental fee will secure the rental time, location, and date. To receive the full refund of the deposit within ten (10) days after the party, the renter must:

- a. Ensure that all garbage is removed and placed in the dumpster.
- b. Remove all displays, favors or remnants of the event.
- c. Restore the furniture and other items to their original position.
- d. Wipe off counters, table tops and sink area.
- e. Replace garbage liner.
- f. Clean out and wipe down the refrigerator, and all cabinets and appliances used.
- g. Clean any windows and doors in the rented area.
- h. Ensure that no damage has occurred to the Amenity Facility.
- i. Patron and Patron's guests are required to adhere to all Amenity Facility rules and policies.

Failure to comply with such rules and policies may result in the forfeiture of Patron's deposit. Pets (with the exception of "Service Animals") are prohibited from any and all rented facilities.

Damage Assessment: The District may retain all or part of any deposit if the District determines, in its sole discretion, that it is necessary to repair any damages (including any clean-up costs) arising from the rental. If additional damages have occurred to the property, the renter will be responsible for any additional cost to return property to original condition it was rented. The deposit will be returned within 10 days of rental if no costs to repair have occurred.

F. Alcohol Service Policies

Alcohol Notification: Patrons intending to serve alcohol at a rented facility must so indicate on the Facility Use Application. Any Patron who does not so indicate at the time the application is submitted shall not be permitted to serve alcohol.

Insurance Requirements: Event Liability insurance coverage in the amount of One Million Dollars (\$1,000,000) will be required for all events that are approved to serve alcoholic beverages. The District, the Board, and District staff and consultants are to be named on these policies as additional insureds.

Indemnification Agreement: Patrons serving alcohol agree to indemnify and hold harmless the District, Amenity Services Group and their Supervisors, officers, directors, consultants and staff from any and all liability, claims, actions, suits, or demands by any person, corporation or other entity, for injuries, death property damage of any nature, arising out of, or in connection with the service of alcohol. Patrons agree that such indemnification shall not constitute or be construed as a waiver of the District's sovereign immunity granted pursuant to Section 768.28, Florida Statutes.

Bartender Requirements: Patrons must hire a certified bartender to dispense alcohol. Events, during which alcohol is served, may have additional requirements for private security services.

G. Additional Event Policies

Capacity and Safety: The following additional policies apply to any rental of an Amenity Facility or space:

- a. The capacity limit of any portion of the Amenity Facility or space shall not be exceeded at any time for a party or event.
- b. The volume of live or recorded music must not violate applicable Duval County noise ordinances, or unreasonably interfere with residents' enjoyment of their homes.
- c. The Amenities may be rented for parties and events during normal operating hours. Additionally, the clubhouse may be rented after hours and until 11:00pm. All parties and events, including clean-up, at the clubhouse must conclude by midnight.
- d. No decorations may be affixed to the walls, doors or any fixtures.
- e. Event Liability coverage may be required, even in the absence of alcohol service, on a case-by-case basis in the sole discretion of the Board of Supervisors.

- f. Patron and Patron's Guests are required to adhere to all Amenity Facility rules, policies, and directions from Amenity Facility staff.
 - g. No glass or breakable items are permitted in the Pool Area.
-

IX. NO FISHING POLICY

WATER FEATURE RESTRICTIONS

Environmental and Safety Protections

Patrons may not fish from any District owned lake/retention pond within the Beach Community Development District. No watercrafts of any kind are allowed in these bodies of water except for small remote-controlled boats intended for recreational purposes. Swimming is also prohibited in any of the waters.

Safety and Environmental Reasons: Water features are designed for stormwater management, not recreation. There are potential safety hazards from water depth and conditions, and the District maintains these policies for protection of local wildlife and ecosystem, as well as compliance with environmental regulations.

X. ENFORCEMENT AND DISCIPLINARY PROCEDURES

SUSPENSION AND TERMINATION OF PRIVILEGES

Section 1: Introduction

This rule addresses the suspension and termination of privileges to use the Beach Community Development District's ("District") recreational facilities ("Amenities").

Section 2: Violations

The privileges of a patron of the Amenities, including resident owners, designated tenants, non-residents who pay the applicable non-resident usage fee, and members of the households of any of the foregoing (collectively, "Patron"), to use the Amenities will be suspended or terminated if the Patron engages in any of the following violations:

Violation Categories:

- a. Submits false information on any application for use of the Amenities.
- b. Permits the unauthorized use of an amenity pass.

- c. Exhibits unsatisfactory behavior, deportment or appearance.
- d. Fails to pay fees owed to the District in a proper and timely manner.
- e. Fails to abide by any policies or rules established for the use of the Amenities.
- f. Treats the District's supervisors, staff, facility management, contractors, or other representatives, or other Patrons, in an unreasonable or abusive manner.
- g. Does not follow instructions of the Amenity Manager or staff or provides false answers to the Amenity Manager or staff upon questioning.
- h. Damages or destroys District property.
- i. Engages in conduct that is improper or likely to endanger the welfare, safety, harmony or reputation of the District, or its supervisors, staff, facility management, contractors, or other representatives, or other Patrons.

Section 3: Reporting of Violations

For all offenses outlined in Section 2 above, the District Manager, or District's Amenity Manager, will create a written report of the incident, which will be signed by the offending Patron and the District Manager or Amenity Manager, as the case may be, and kept on file by the District. If the offending Patron refuses to sign the incident report, it will be kept on file by the District with a notation to that effect by the District Manager or the Amenity Manager, as the case may be. This report will have the incident listed, with date, and a warning of the suspension policy of their next offense. These offenses should be reported to the Board of Supervisors at monthly meetings.

Complaint Process: Patrons may file a complaint to the Amenity Manager at any time. If a Patron files a complaint, this complaint must have a response to the complaint within 72 hours. Response should state the actions that will be taken as a result of the complaint.

Section 4: Suspension Procedures

Immediate Suspension Authority: The Amenity Manager has the ability to immediately remove any person from one or all Amenities or Issue a suspension for up to 30 days for infractions including but not limited to those Violations described above. These infractions involve use of profanity or vulgarity, failure to follow staff directions, disrespect, or threats toward staff or other Patrons, disruptions of the operation and activities of the Amenities or when such action is necessary to protect the health, safety, and the welfare of Patrons or their guest(s) or to protect the Districts facilities from damage.

Progressive Discipline System:

First Offense: Verbal or written warning by Amenity Staff. Violation is recorded by Amenity staff and held on file by the District.

Second Offense: Automatic suspension of all Amenity privileges for up to thirty days from the commencement of the suspension, with the preparation by District Staff of a written report to be signed by the offender(s) and filed with the District. Failure or refusal of the offender to sign the report will not invalidate the suspension.

Third Offense: Suspension of all Amenity privileges for up to one (1) year. Such suspension shall run to the next regular meeting of the Board of Supervisors. At said meeting, the record of all previous offenses will be presented to the Board for recommendation of termination of the offender(s) privileges for one (1) calendar year. The length of the suspension is in the discretion of the Board and may be for less than one (1) year.

Household Suspensions: Suspensions can be the entire household depending on violations and who the violators are (i.e., children or guests of resident).

Emergency Response: Any violent confrontations happening on Amenity Facilities, Call 911.

Section 5: Suspension of Minors

Any Resident under the age of eighteen (18) who is suspended from the facility three (3) times in a one-year period, shall, until the child reaches the age of eighteen (18), only be entitled to use the facility if accompanied by a parent, legal guardian, or adult Patron at all times.

Section 6: Appeal of Suspension

The District Manager, or the District's Amenity Manager, may at any time suspend a Patron's privileges to use the Amenities for committing any of the violations outlined in Section 2. Such suspension shall be for a maximum period of 30 consecutive days. In determining the length of any suspension, the District Manager, or Amenity Manager, shall take into account the nature of the conduct and any prior violations.

Appeal Process: A Patron subject to a suspension under this Section may appeal the suspension to the District's Board of Supervisors ("Board") by filing a written request for an appeal, which shall be immediately sent to the District's Chairperson. The filing of a request for an appeal shall not result in the stay of the suspension. The District shall consider the appeal at its next Board meeting and shall provide reasonable notice to the Patron of the Board meeting where the appeal will be considered. At that meeting, the Board shall allow the Patron to appear and present statements and/or evidence on the Patron's behalf, subject to any reasonable restrictions that the Board may impose. The Board may take any action deemed by it in its sole discretion to be appropriate under the circumstances, including affirming, overturning, or otherwise modifying the suspension, to address the appeal and any violations outlined in Section 2. In determining the appropriate action to be taken, the Board shall take into account the nature of the violation and any prior violations.

Section 7: Suspension or Termination by the Board

The District Manager, or the District's Amenity Manager, may recommend to the Board, or the Board on its own initiative may elect to consider, a suspension or termination of a Patron's privileges for committing any of the violations outlined in Section 2. At least 15 days prior to any Board meeting where a suspension or termination is to be considered under this Section, the District will send written notice of the meeting by United States mail to the Patron's last known

address. Upon prior written request submitted by the Patron to the District at least 5 days prior to the meeting, the Board shall allow the Patron to appear at the meeting and present statements and/or evidence on the Patron's behalf, subject to any reasonable restrictions that the Board may impose. The Board may take any action deemed by it in its sole discretion to be appropriate under the circumstances to address the violations outlined in Section 2, including suspension or permanent termination of a Patron's privileges to use the Facilities. In determining the appropriate action to be taken, the Board will take into account the nature of the violation and any prior violations.

Section 8: Trespass

If a Patron subject to a suspension or termination is found on the Amenity premises, such Patron will be subject to arrest for trespassing.

XI. CONSENT TO VIDEO AND AUDIO MONITORING

To promote the safety and security of the District, its Amenity Facilities, and all guests and occupants, and to support the effective administration of facility rules, the District may, at its discretion, install and operate video and/or audio monitoring systems on District property. By accessing or utilizing any Amenity Facility or other District-owned property, individuals acknowledge and consent to the electronic recording and storage of video and/or audio data. These recordings may be used to verify compliance with District policies and investigate reported incidents. The District reserves the right to disregard any incident report submitted more than thirty (30) days after the alleged injury or rule violation, as delayed reporting may hinder the District's ability to review and substantiate the event using available electronic records.

XII. APPENDICES

APPENDIX A: EMERGENCY PROCEDURES

Emergency Services Contact Information: 911

Medical Emergency Procedures:

1. Call 911 immediately
2. Provide first aid if trained and safe to do so
3. Notify Amenity Manager as soon as possible
4. Complete incident report within 24 hours
5. Cooperate with emergency responders

Facility Emergency Procedures:

1. Seek shelter in designated safe areas
2. Wait for all-clear before resuming activities
3. Report any damage immediately

APPENDIX B: CONTACT INFORMATION

District Management:

- Vesta District Services
- 250 International Parkway, Suite 208
- Lake Mary, FL 32746
- Phone: [<https://www.beachcdd.com/contacts>]
- Email: [<https://www.beachcdd.com/contacts>]
- Website: [<https://www.beachcdd.com/>]

Amenity Manager:

- Oliver Ingram
- Phone: [+1-904-329-2277]
- Email: [oingram@vestapropertyservices.com]

Board of Supervisors:

- Meeting Schedule: [<https://www.beachcdd.com/meetings>]
- Board Member Contact: [<https://www.beachcdd.com/contacts>]

APPENDIX C: FORMS AND APPLICATIONS

Required Forms Available:

- Contact Amenity Manager for: Facility Use Application, Rental Agreement, Instructor/Trainer Application, Community Club Application, Non-Resident Membership Application, Incident Report Form, Equipment Checkout Form, etc.

Online Resources:

- Community website: [<https://tamayaamenities.com/>]
- Newsletter signup: [Contact Amenity Manager]

APPENDIX D: FACILITY RENTAL RATES

- All rates subject to 2% Credit Card Convenience Fee

Facility	Duration	Capacity	Rental Rate	Security Deposit
Boardroom	Up to 4 Hours	12 people	\$150 (Additional \$25 p/hour)	\$150
Pool Cabana	Up to 4 Hours	25 people	\$150 (Additional \$25 p/hour)	\$150
Palm Court & Bar	Up to 4 Hours	50 people	\$200 (Additional \$25 p/hour)	\$200
Tamaya Hall	Up to 6 Hours	80 people	\$700 (Additional \$25 p/hour)	\$750
Tamaya Hall, Palm Court & Bar	Up to 8 Hours	80 people (does not include use of Pool)	\$1500	\$750
Group Fitness Room	Up to 4 Hours	25 people	\$200	\$350
Large Event Lawn	Up to 8 Hours	Special Conditions	No Charge	\$350

POLICY ACKNOWLEDGMENT

By using any Beach Community Development District amenity facility, all patrons acknowledge they have read, understood, and agree to comply with all policies contained herein. These policies are subject to change with proper notice as determined by the Board of Supervisors.

Effective Date: December 15, 2025

Document Version: Comprehensive Amenity Facility Policies - Version 202512

Board Approval: December 15, 2025

This document represents the comprehensive amenity policies for the Beach Community Development District. For questions or clarifications, contact the Amenity Manager or District Manager at the contact information provided above.

Important Legal Notice: These policies are established by the Beach Community Development District Board of Supervisors and carry the full force of District regulations. Violations may result

in suspension or termination of amenity privileges and may be subject to legal enforcement. All patrons are responsible for ensuring their guests and family members comply with these policies.

Americans with Disabilities Act Compliance: The Beach Community Development District is committed to providing equal access to all amenity facilities in compliance with the Americans with Disabilities Act. Reasonable accommodations will be made upon request. Contact the District Manager for accommodation requests.

Non-Discrimination Policy: The Beach Community Development District provides amenity services without regard to race, color, religion, sex, national origin, age, disability, or any other characteristic protected by law.

APPENDIX D: FACILITY RENTAL RATES (effective 01/12/2026)

SUBJECT TO PUBLIC HEARING AND BOARD APPROVAL TBD

- All rates subject to 3% Credit Card Convenience Fee

Facility	Duration	Capacity	Rental Rate	Security Deposit
Boardroom	Up to 4 Hours	12 people	\$200 (Additional \$50 p/hour)	\$150
Pool Cabana	Up to 4 Hours	25 people	\$200 (Additional \$50 p/hour)	\$150
Palm Court & Bar	Up to 4 Hours	50 people	\$250 (Additional \$50 p/hour)	\$200
Tamaya Hall	Up to 6 Hours	80 people	\$850 (Additional \$50 p/hour)	\$750
Tamaya Hall, Palm Court & Bar	Up to 8 Hours	80 people (does not include use of Pool)	\$1500	\$750
Group Fitness Room	Up to 4 Hours	25 people	\$250	\$350
Large Event Lawn	Up to 8 Hours	Special Conditions	No Charge	\$350

TAMAYA AMENITY CENTER: COMPREHENSIVE FACILITY RENTAL AGREEMENT

This **Master Facility Rental Agreement** ("Agreement") is entered into between the **Beach Community Development District** ("District"), located at 250 International Pkwy., Suite 208, Lake Mary, FL 32746, and the undersigned **Resident/Member** ("Renter").

The Tamaya Amenity Center is located at 12788 Meritage Blvd., Jacksonville, FL 32246. This unified document incorporates all policies regarding space usage, fees, conduct, and legal responsibilities for the temporary use of the Tamaya Amenity Center.

SECTION I: RESIDENT AND EVENT REGISTRATION DATA

The following information must be provided in full at the time of application to ensure all necessary data is captured for the booking.

1.1 Resident Information

Field	Resident Data
Full Legal Name	
Tamaya Address	
Primary Phone Number	
Primary Email Address	
Emergency Contact Name	
Emergency Contact Phone	
Today's Date	

1.2 Event Specifications

Field	Data
Date of Reservation	
Type of Event	
Total Expected Attendance	
Setup\Access Time	
Event Start Time	AM/PM
Event End Time	AM/PM
Cleanup/Departure Time	AM/PM

Field	Data
Total Block Hours	

SECTION II: FACILITY SELECTION AND CAPACITY VERIFICATION

Check the specific area(s) to be reserved. Standard durations and attendee limits apply.

Selection	Facility Area	Max Capacity	Standard Duration	Rental Fee	Security Deposit
<input type="checkbox"/>	Boardroom	12	4 Hours	\$200.00	\$150.00
<input type="checkbox"/>	Group Fitness Room	25	4 Hours	\$250.00	\$150.00
<input type="checkbox"/>	Pool Cabana (Includes pool access)	25	4 Hours	\$200.00	\$150.00
<input type="checkbox"/>	Palm Court and Bar	50	4 Hours	\$250.00	\$350.00
<input type="checkbox"/>	Tamaya Hall (Hardwood floors - Addendum applies)	80	6 Hours	\$850.00	\$750.00
<input type="checkbox"/>	Combo (Hall, Palm Court, and Bar)	130	8 Hours	\$1,250.00	\$750.00
<input type="checkbox"/>	Large Event Lawn	100	8 Hours	\$0.00	\$350.00

SECTION III: VENDOR AND SERVICE DETAILS

All third-party vendors must be identified and provide proof of insurance.

Field	Data
Catering Services	<input type="checkbox"/> Yes <input type="checkbox"/> No
Catering Company Name	
Catering business contact	
Alcohol Service	<input type="checkbox"/> Yes <input type="checkbox"/> No (Requires Licensed Bartender and Security)

Field	Data
Licensed Bartender Name	
Entertainment (DJ, Band, etc.)	

SECTION IV: SECURITY AND INSURANCE REQUIREMENTS

Security is mandatory for events past 6:00 PM, over 25 guests, or where alcohol is present.

Field	Data
Security Officer Required?	<input type="checkbox"/> Yes <input type="checkbox"/> No
Total Security Hours Required	
Liability Insurance Certificate Received?	<input type="checkbox"/> Yes <input type="checkbox"/> No
Insurance Requirements	\$1,000,000.00 limit, naming Beach CDD as co-insured/certificate holder

SECTION V: FINANCIAL SUMMARY AND PAYMENT TRACKING

Payments must be made via two separate checks or money orders payable to Beach CDD.

Payment Category	Amount Due	Check #	Date Collected
Base Rental Fee	\$		
Security Deposit	\$		
Addl. Hours (\$50/hr.)	\$		
TOTALS	\$		

SECTION VI: GENERAL RESERVATION POLICIES AND ELIGIBILITY

6.1 Residency and Good Standing

The use of the Tamaya Amenity Center is a privilege reserved exclusively for **Residents and Members in good standing** with the District. Good standing implies the Renter has no outstanding violations or unpaid fees owed to the District. All reservations must be made by a

Resident, and the Resident **must be present** for the entire duration of the event, including setup and teardown.

6.2 Reservation Timelines and Frequency

Lead Time: Reservations must be submitted in person at least **two (2) weeks (14 days)** prior to the event.

Advance Booking: Reservations may be made up to **four (4) months** in advance. **Weddings and receptions** may be booked up to **one (1) year** in advance with District approval.

Frequency Limit: Each household is limited to renting facility portions no more than **six (6) times per calendar year**.

6.3 Availability and Blackout Dates

The Tamaya Amenity Center is **unavailable for private events** on major holidays and holiday weekends, including:

- Easter, July 4th, Thanksgiving, Christmas Eve/Day, and New Year's Eve/Day
- Memorial Day Weekend and Labor Day Weekend
- Any weekend where a federal holiday falls on a Monday or Friday (with the exception of MLK Day, Washington's Birthday, Columbus Day, and Veterans Day)

SECTION VII: ATTENDANCE AND GUEST MANAGEMENT

7.1 Occupancy Limits

The Renter agrees to strictly adhere to the maximum occupancy limits listed in Section II. These capacities are set by building and fire codes. The Facility Manager has the discretion to limit event size further after reviewing event details. **Any guests in excess of the approved number will be turned away** by staff or security.

7.2 Renter Responsibility

The Renter represents they have the authority to bind all attendees and vendors to the terms of this Agreement. The Renter is solely responsible for the conduct of all guests and any damage they may cause.

SECTION VIII: OPERATIONAL HOURS AND CURFEWS

8.1 Total Block Time

The "Time of Reservation" is the "Total Block Time," which must include time for vendor deliveries, setup, the event itself, and post-event cleanup/load-out. Access will not be granted before the start time, and the facility must be vacated by the end time to avoid charges.

8.2 Additional Time and Extensions

Indoor areas (excluding the Large Event Lawn) may be rented for an additional **\$50.00 per hour** beyond the standard duration. All additional hours must be paid for at the time of registration. Staying past the scheduled end time without approval will result in **deposit forfeiture**.

SECTION IX: FINANCIAL OBLIGATIONS AND DEPOSITS

9.1 Payment Submission

At the time of reservation, the Renter must submit **two (2) separate checks or money orders** made payable to the **Beach Community Development District** (or Beach CDD): one for the Rental Fee and one for the Security Deposit.

9.2 Security Deposit Conditions

The security deposit is a performance bond held to ensure compliance with cleaning standards and to cover potential damage. The District may retain all or part of the deposit for:

- **Property Damage:** Repairs to floors, walls, furniture, or equipment
- **Insufficient Cleaning:** Failure to remove trash, wipe surfaces, or clean appliances
- **Rule Violations:** Using prohibited items like tape on walls, glitter, or unauthorized movement of furniture
- **Late Departure:** Staying past the contracted block time

9.3 Refund Timeline

Refunds for security deposits are typically processed within **10 to 30 days** after a successful post-event inspection.

SECTION X: MANDATORY SECURITY AND AFTER-HOURS STAFFING

10.1 Requirements for Security Personnel

A professional security officer, hired through the District's approved vendor at the Renter's expense, is **mandatory** for:

- Any event where **alcohol is present** (regardless of time or attendee count)
- Any reservation in Tamaya Hall or Palm Court extending **past 10:00 p.m.**

10.2 Security Costs and Authority

Security is renter's choice as long as licensed and insured.

Security services are billed directly to the renter. The security officer has the authority to enforce rules, monitor noise, and **terminate an event immediately** for serious violations or illegal activity.

SECTION XI: ALCOHOL AND CATERING POLICIES

11.1 Alcohol Consumption and Insurance

Prior Approval: Alcohol must be disclosed and approved at the time of application.

Insurance: Event Liability Insurance of **\$1,000,000.00** naming Beach CDD as co-insured and certificate holder is **required** and must be submitted 14 days prior to the event.

Service: A **licensed bartender** must serve all alcohol; self-service is prohibited.

Prohibited Areas: Alcohol is strictly prohibited in the pool area, waterslide area, and fitness center.

Age Restrictions: No service is permitted to minors (under 21) or intoxicated persons.

11.2 Catering and Kitchen Usage

Vendor Disclosure: Renters must identify catering companies on the application.

Kitchen Standards: Tamaya Hall includes a kitchen for staging and warming; it is not for high-grease cooking. All equipment must be cleaned, and the refrigerator emptied and wiped at the conclusion of the event.

Caterer Insurance: Professional caterers must provide proof of insurance, including liquor liability if serving alcohol.

SECTION XII: CONDUCT, DECORATIONS, AND PROHIBITED ITEMS

12.1 Decorating Guidelines

Tabletop Only: Decorations are limited to **tabletops only**. No wall or ceiling decorations are permitted.

Prohibited Attachments: No tape, nails, staples, tacks, or adhesives may be used on walls, woodwork, or ceilings.

Prohibited Items: No confetti, glitter, rice, birdseed, or smoke/fog machines.

Fire Safety: No candles or open flames are permitted.

Table Linens: Linens **must be used** on all tables if food is served to protect the furniture surfaces.

12.2 General Conduct

No Smoking: All indoor facilities are smoke-free; smoking and vaping are prohibited.

Commercial Activity: Facilities may not be used for profit-making, commercial activity, solicitation, or for-profit engagements.

Illegal Activity: Engaging in illegal activity results in immediate arrest and removal.

Animals: Pets are prohibited; only **documented service animals** with proper identification are permitted.

SECTION XIII: PARKING AND ACCESS RESTRICTIONS

13.1 Parking Lot Usage

Capacity: Use is restricted to the parking lot, which has a maximum capacity of **96 vehicles**.

Prohibited Areas: Parking on the Event Lawn or grass is strictly prohibited and subject to towing.

13.2 Limited Access

Non-Exclusive Amenities: The Swimming Pool, Waterslide Area, and Fitness Center are community assets and **cannot be reserved for exclusive use**.

Reserved Access: Access is limited strictly to the area booked. No access is granted to tennis or basketball courts.

Pool Access: The **Pool Cabana** and **Palm Court** are the only rentals that permit guest access to the pool.

SECTION XIV: TAMAYA HALL PREMIUM FACILITY ADDENDUM

Tamaya Hall is the premier asset of the Tamaya community, featuring high-performance hardwood floors and premium custom finishes. Because this space is a "showcase" status, the District maintains an uncompromising standard for its care.

14.1 Absolute Furniture Prohibition

Under no circumstances shall any furniture (tables, chairs, sofas) be dragged, slid, or moved by the Renter, guests, or vendors. Moving furniture risks scratching the floors and will result in **immediate and automatic forfeiture of 100% of the security deposit (\$750.00)**. Custom layouts must be requested 7 days in advance for staff approval and instruction with supervision.

14.2 Rigorous Floor Protection and Decoration Rules

Vendor Equipment: All external equipment (DJ booths, catering carts, photo booths) must have non-marring rubberized feet or be placed on District-approved protective mats/rugs.

Footwear and Spills: Guests are discouraged from wearing stiletto heels (≥ 2.5 in), metal cleats, or spikes. All liquid spills must be blotted immediately.

Restricted Adhesives: No tape, nails, staples, tacks, or screws may be applied to walls, woodwork, or floors. Decorations are limited to **tabletops only**.

Fire Safety: No candles, open flames, smoke machines, or fog machines are permitted.

14.3 Mandatory Photo-Audit Protocol

To ensure transparency and protect the Renter from liability for pre-existing conditions, the following "Photo-Audit" is required:

1. **Pre-Event Photos:** Renter must take **time-stamped photographs** of the entire hall (floors, furniture legs, kitchen, and walls) immediately upon arrival and prior to any setup.
2. **Post-Event Photos:** Renter must take an identical set of photos after cleanup but before departure.
3. **Legal Assumption:** Failure to capture "Before" photos constitutes a binding admission that the facility was in perfect, pristine condition upon arrival.

14.4 Kitchen and Restoration Standards

Tamaya Hall must be returned in "Guest-Ready" condition.

Category	Requirement
Kitchen	Appliances wiped clean; refrigerator emptied/wiped; sink cleared of debris
Trash	All waste bagged and moved to external District dumpster; new liners installed
Surfaces	Tabletops and bar areas wiped free of sticky residue/spills; linens must be used if food is served
Floors	Entire area swept and spot-mopped using only District-approved cleaning agents

14.5 Financial Obligations and Staffing for Tamaya Hall

Fees: Rental is **\$850.00** (6-hour limit) or **\$1,250.00** for a Combo rental (8-hour limit).

Security Deposit: A **\$750.00** performance bond is required at the time of booking.

Mandatory Security: A security officer is required for events with alcohol, >25 guests, or extending past 10:00 p.m.

Alcohol: Requires **\$1,000,000.00** liability insurance naming the District as co-insured and a licensed bartender.

SECTION XV: CLEANUP AND RESTORATION REQUIREMENTS

The facility must be returned in "Guest-Ready" condition to receive a full deposit refund.

Requirement Category	Cleaning Task
Trash Disposal	All trash removed to external District dumpster; liners replaced
Surfaces	All tabletops, counters, and bar areas wiped clean of residue
Kitchen	Refrigerator emptied and wiped; microwave cleaned; sinks cleared
Floors	All floors swept and spot-mopped for spills using approved agents
Furniture	Tables and chairs returned to exact original positions (lifting, not dragging)
Decorations	All tape, balloons, string, and signage removed; no wall damage
Glass/Restrooms	Handprints wiped from glass doors; toilets flushed; debris removed
Personal Property	All catering supplies and personal items removed from premises

SECTION XVI: LEGAL, CANCELLATION, AND INDEMNIFICATION

16.1 Cancellation Policy

Full Refund: Written notice must be communicated at least **two (2) weeks (14 days)** prior to the event.

Late Cancellation: If cancelled less than two weeks prior, the **security deposit is forfeited**, though the rental fee is returned.

No-Show: Reservations are considered cancelled if the Renter is more than **15 minutes late** for the start time, resulting in forfeiture of fees and deposits.

16.2 Indemnification and Liability

The Renter agrees to defend, indemnify, and hold harmless the Beach Community Development District, its supervisors, and staff from all liability, claims, actions, or personal property damage arising from the use of the facilities. Nothing in this Agreement waives the District's sovereign immunity under Section 768.28, Florida Statutes.

SECTION XVII: FACILITY INSPECTION CHECKLIST

This section must be completed by District Staff for office use.

Field	Data
Resident Check-in Time	
Check-out Time	
Floors (Scratches)	Pre-Event: ____ Post-Event: ____ Staff Notes:
Furniture Layout	Pre-Event: ____ Post-Event: ____ Staff Notes:
Kitchen Cleanliness	Pre-Event: ____ Post-Event: ____ Staff Notes:
Trash/Liners	Pre-Event: ____ Post-Event: ____ Staff Notes:
Wall/Paint Condition	Pre-Event: ____ Post-Event: ____ Staff Notes:

Final Disposition of Deposit:

- Full Refund Approved
- Partial Deduction:
Reason _____ (Amt: \$ _____)
- Total Forfeiture:
Reason _____ (Amt: \$ _____)

SECTION XVIII: PRE-EVENT INSPECTION (CHECK-IN)

This section must be completed before any setup or decorations are placed.

Item / Area	Satisfactory? (Y/N)	Pre-Existing Damage / Notes
Floors (Hardwood/Tile/Carpet)		Note any scratches, scuffs, or stains
Furniture (Tables/Chairs/Sofas)		Count present and verify integrity
Walls, Doors, and Baseboards		Note existing marks or adhesive residue
Windows and Glass Doors		Inspect for smudges or fingerprints
Kitchen:		Verify fridge is empty and microwave is

Item / Area	Satisfactory? (Y/N)	Pre-Existing Damage / Notes
Appliances/Countertops		clean
Lighting and HVAC Panels		Confirm functional settings
Trash Receptacles		Ensure all bins are empty with liners

Mandatory Requirement: The Resident is **strongly encouraged** to take **time-stamped photographs** of the facility (floors, furniture legs, and surfaces) upon arrival to establish a baseline.

SECTION XIX: POST-EVENT CLEANUP CHECKLIST (GUEST-READY STANDARDS)

The Renter must satisfy all of the following conditions to be eligible for a full deposit refund.

19.1 General Area Restoration

- **Furniture:** All tables and chairs returned to their **exact original positions**
- **Furniture Movement:** Absolutely no furniture was **dragged or slid** across hardwood floors (Tamaya Hall)
- **Trash Disposal:** All waste bagged, tied, and removed to the **external District dumpster**
- **Liners:** New trash bags/liners installed in all internal receptacles
- **Surfaces:** All tabletops, bar areas, and counters wiped free of sticky residue and debris
- **Decorations:** All tape, strings, balloons, and signs removed; no damage from adhesives

19.2 Kitchen and Appliances

- **Refrigerator:** Completely emptied and interior/exterior wiped down
- **Microwave:** All food residue, grease, and splatters cleaned
- **Sinks and Cabinets:** Sinks cleared and scrubbed; all used cabinets wiped out

19.3 Floors, Glass, and Utilities

- **Floors:** Swept completely and spot-mopped using **District-approved chemicals only**
 - **Glass Doors/Windows:** Handprints and smudges wiped from all glass surfaces
 - **Restrooms:** Toilets flushed and floors cleared of debris
 - **HVAC and Lights:** Lights off and HVAC returned to **76°F / standard unoccupied settings**
-

SECTION XX: FINAL INSPECTION AND DISPOSITION

To be completed by a District Representative after the Renter completes cleanup.

Area	Satisfactory? (Y/N)	Staff Notes / Deduction Charges
Trash and Liners		\$
Floor Condition		\$
Furniture Layout		\$
Kitchen Restoration		\$
Rule Compliance		\$

Deposit Disposition:

- Full Refund Approved
- Partial Deduction:
Reason _____ (Amt: \$ _____)
- Total Forfeiture:
Reason _____ (Amt: \$ _____)

Note: Security deposits are typically processed via check within **10–30 business days** following a satisfactory inspection.

SECTION XXI: ACKNOWLEDGMENT, AUTHORIZATION, AND SIGNATURE

By signing below, the Resident/Member acknowledges and represents as follows:

ACKNOWLEDGMENT OF RECEIPT AND REVIEW: I acknowledge that I have received, read, and fully understand this comprehensive Master Facility Rental Agreement, including all Sections I through XXI contained herein. I have received the full Facility Use Agreement and agree to adhere to all rules, including the **Tamaya Hall Addendum** (if applicable), which strictly prohibits the movement of furniture and requires mandatory photographic documentation to protect the security deposit.

AUTHORIZATION TO BIND ATTENDEES: I represent that I have the full authority to execute this Agreement and to bind all attendees, guests, vendors, contractors, and other persons participating in or attending the event covered by this Agreement to all terms and conditions

contained herein. I accept full responsibility for the conduct of all such persons and for any damage they may cause to the Premises.

ACKNOWLEDGMENT OF STRICT DEPOSIT REQUIREMENTS: I understand that Tamaya Hall contains immaculate hardwood floors and new, premium furniture that require special protection. I acknowledge that the requirements for return of the security deposit are extremely strict. I specifically understand and agree that:

- **NO FURNITURE SHALL BE MOVED, RELOCATED, OR REARRANGED UNDER ANY CIRCUMSTANCES** without the prior written approval of the Facility Manager. Any unauthorized movement of furniture will result in the immediate and automatic forfeiture of 100% of the security deposit (\$750.00).
- I am strongly encouraged to take comprehensive time-stamped photographs of the Premises before and after the event to document the condition and protect myself from liability for pre-existing conditions.
- Failure to take "Before" photographs constitutes a binding admission that the facility was in perfect, pristine condition upon my arrival.
- I accept full financial liability for any damage exceeding the security deposit, including floor refinishing or furniture replacement costs.

COMPLIANCE WITH RULES AND REGULATIONS: I agree to comply with all rules, regulations, policies, and directions from Amenity Facility Staff. I understand that any violation—particularly regarding furniture movement, floor care, unauthorized area access (Pool/Slide), or prohibited items—will result in the total forfeiture of the Security Deposit and potential additional billing.

INDEMNIFICATION AND HOLD HARMLESS: In consideration of being permitted to use the Premises, I hereby agree to defend, indemnify, and hold harmless the Beach Community Development District, its supervisors, agents, employees, and contractors from any and all liability, claims, actions, suits, or demands by any person, corporation, or other entity for any injuries, death, theft, and real or personal property damage of any nature arising out of or in connection with the use of the facilities contemplated by this Agreement.

UNDERSTANDING OF CONSEQUENCES: I understand that failure to comply with the requirements of this Agreement may result in: forfeiture of all or part of the security deposit; additional charges for damage; immediate termination of the event; and loss of future rental privileges.

STEWARDSHIP RESPONSIBILITY: By renting Tamaya Hall or any facility of the Tamaya Amenity Center, I accept a responsibility to serve as a steward of these valuable community assets. I agree to use the facility only for its intended purposes, leave the facility in the same or better condition than it was found, report any damage or maintenance issues to the District, and encourage guests to respect the facility and its rules.

RENTER SIGNATURE AND CERTIFICATION

By signing below, I, the undersigned, hereby certify that I have read and understand this entire Agreement, that all information provided by me is accurate and complete, that I have had the opportunity to ask questions and receive satisfactory answers, and that I agree to be bound by all terms, conditions, and obligations set forth herein.

Resident/Member Signature:	
Printed Name:	
Date:	

DISTRICT REPRESENTATIVE ACKNOWLEDGMENT

District Representative Signature:	
Printed Name/Title:	
Date:	

WITNESS ACKNOWLEDGMENT (OPTIONAL)

Witness Signature:	
Printed Name:	
Date:	

Beach Community Development District 250 International Pkwy. Suite 208, Lake Mary, FL
32746 Phone: 904-329-2277

Document Revision Date: March 2026

EXHIBIT 17

TAMAYA AMENITY CENTER: COMPREHENSIVE FACILITY RENTAL AGREEMENT

This **Master Facility Rental Agreement** ("Agreement") is entered into between the **Beach Community Development District** ("District"), located at 250 International Pkwy., Suite 208, Lake Mary, FL 32746, and the undersigned **Resident/Member** ("Renter").

The Tamaya Amenity Center is located at 12788 Meritage Blvd., Jacksonville, FL 32246. This unified document incorporates all policies regarding space usage, fees, conduct, and legal responsibilities for the temporary use of the Tamaya Amenity Center.

SECTION I: RESIDENT AND EVENT REGISTRATION DATA

The following information must be provided in full at the time of application to ensure all necessary data is captured for the booking.

1.1 Resident Information

Field	Resident Data
Full Legal Name	
Tamaya Address	
Primary Phone Number	
Primary Email Address	
Emergency Contact Name	
Emergency Contact Phone	
Today's Date	

1.2 Event Specifications

Field	Data
Date of Reservation	
Type of Event	
Total Expected Attendance	
Setup\Access Time	
Event Start Time	AM/PM
Event End Time	AM/PM
Cleanup/Departure Time	AM/PM

Field	Data
Total Block Hours	

SECTION II: FACILITY SELECTION AND CAPACITY VERIFICATION

Check the specific area(s) to be reserved. Standard durations and attendee limits apply.

Selection	Facility Area	Max Capacity	Standard Duration	Rental Fee	Security Deposit
<input type="checkbox"/>	Boardroom	12	4 Hours	\$200.00	\$150.00
<input type="checkbox"/>	Group Fitness Room	25	4 Hours	\$250.00	\$150.00
<input type="checkbox"/>	Pool Cabana (Includes pool access)	25	4 Hours	\$200.00	\$150.00
<input type="checkbox"/>	Palm Court and Bar	50	4 Hours	\$250.00	\$350.00
<input type="checkbox"/>	Tamaya Hall (Hardwood floors - Addendum applies)	80	6 Hours	\$850.00	\$750.00
<input type="checkbox"/>	Combo (Hall, Palm Court, and Bar)	130	8 Hours	\$1,250.00	\$750.00
<input type="checkbox"/>	Large Event Lawn	100	8 Hours	\$0.00	\$350.00

SECTION III: VENDOR AND SERVICE DETAILS

All third-party vendors must be identified and provide proof of insurance.

Field	Data
Catering Services	<input type="checkbox"/> Yes <input type="checkbox"/> No
Catering Company Name	
Catering business contact	
Alcohol Service	<input type="checkbox"/> Yes <input type="checkbox"/> No (Requires Licensed Bartender and Security)

Field	Data
Licensed Bartender Name	
Entertainment (DJ, Band, etc.)	

SECTION IV: SECURITY AND INSURANCE REQUIREMENTS

Security is mandatory for events past 6:00 PM, over 25 guests, or where alcohol is present.

Field	Data
Security Officer Required?	<input type="checkbox"/> Yes <input type="checkbox"/> No
Total Security Hours Required	
Liability Insurance Certificate Received?	<input type="checkbox"/> Yes <input type="checkbox"/> No
Insurance Requirements	\$1,000,000.00 limit, naming Beach CDD as co-insured/certificate holder

SECTION V: FINANCIAL SUMMARY AND PAYMENT TRACKING

Payments must be made via two separate checks or money orders payable to Beach CDD.

Payment Category	Amount Due	Check #	Date Collected
Base Rental Fee	\$		
Security Deposit	\$		
Addl. Hours (\$50/hr.)	\$		
TOTALS	\$		

SECTION VI: GENERAL RESERVATION POLICIES AND ELIGIBILITY

6.1 Residency and Good Standing

The use of the Tamaya Amenity Center is a privilege reserved exclusively for **Residents and Members in good standing** with the District. Good standing implies the Renter has no outstanding violations or unpaid fees owed to the District. All reservations must be made by a

Resident, and the Resident **must be present** for the entire duration of the event, including setup and teardown.

6.2 Reservation Timelines and Frequency

Lead Time: Reservations must be submitted in person at least **two (2) weeks (14 days)** prior to the event.

Advance Booking: Reservations may be made up to **four (4) months** in advance. **Weddings and receptions** may be booked up to **one (1) year** in advance with District approval.

Frequency Limit: Each household is limited to renting facility portions no more than **six (6) times per calendar year**.

6.3 Availability and Blackout Dates

The Tamaya Amenity Center is **unavailable for private events** on major holidays and holiday weekends, including:

- Easter, July 4th, Thanksgiving, Christmas Eve/Day, and New Year's Eve/Day
- Memorial Day Weekend and Labor Day Weekend
- Any weekend where a federal holiday falls on a Monday or Friday (with the exception of MLK Day, Washington's Birthday, Columbus Day, and Veterans Day)

SECTION VII: ATTENDANCE AND GUEST MANAGEMENT

7.1 Occupancy Limits

The Renter agrees to strictly adhere to the maximum occupancy limits listed in Section II. These capacities are set by building and fire codes. The Facility Manager has the discretion to limit event size further after reviewing event details. **Any guests in excess of the approved number will be turned away** by staff or security.

7.2 Renter Responsibility

The Renter represents they have the authority to bind all attendees and vendors to the terms of this Agreement. The Renter is solely responsible for the conduct of all guests and any damage they may cause.

SECTION VIII: OPERATIONAL HOURS AND CURFEWS

8.1 Total Block Time

The "Time of Reservation" is the "Total Block Time," which must include time for vendor deliveries, setup, the event itself, and post-event cleanup/load-out. Access will not be granted before the start time, and the facility must be vacated by the end time to avoid charges.

8.2 Additional Time and Extensions

Indoor areas (excluding the Large Event Lawn) may be rented for an additional **\$50.00 per hour** beyond the standard duration. All additional hours must be paid for at the time of registration. Staying past the scheduled end time without approval will result in **deposit forfeiture**.

SECTION IX: FINANCIAL OBLIGATIONS AND DEPOSITS

9.1 Payment Submission

At the time of reservation, the Renter must submit **two (2) separate checks or money orders** made payable to the **Beach Community Development District** (or Beach CDD): one for the Rental Fee and one for the Security Deposit.

9.2 Security Deposit Conditions

The security deposit is a performance bond held to ensure compliance with cleaning standards and to cover potential damage. The District may retain all or part of the deposit for:

- **Property Damage:** Repairs to floors, walls, furniture, or equipment
- **Insufficient Cleaning:** Failure to remove trash, wipe surfaces, or clean appliances
- **Rule Violations:** Using prohibited items like tape on walls, glitter, or unauthorized movement of furniture
- **Late Departure:** Staying past the contracted block time

9.3 Refund Timeline

Refunds for security deposits are typically processed within **10 to 30 days** after a successful post-event inspection.

SECTION X: MANDATORY SECURITY AND AFTER-HOURS STAFFING

10.1 Requirements for Security Personnel

A professional security officer, hired through the District's approved vendor at the Renter's expense, is **mandatory** for:

- Any event where **alcohol is present** (regardless of time or attendee count)
- Any reservation in Tamaya Hall or Palm Court extending **past 10:00 p.m.**

10.2 Security Costs and Authority

Security is renter's choice as long as licensed and insured.

Security services are billed directly to the renter. The security officer has the authority to enforce rules, monitor noise, and **terminate an event immediately** for serious violations or illegal activity.

SECTION XI: ALCOHOL AND CATERING POLICIES

11.1 Alcohol Consumption and Insurance

Prior Approval: Alcohol must be disclosed and approved at the time of application.

Insurance: Event Liability Insurance of **\$1,000,000.00** naming Beach CDD as co-insured and certificate holder is **required** and must be submitted 14 days prior to the event.

Service: A **licensed bartender** must serve all alcohol; self-service is prohibited.

Prohibited Areas: Alcohol is strictly prohibited in the pool area, waterslide area, and fitness center.

Age Restrictions: No service is permitted to minors (under 21) or intoxicated persons.

11.2 Catering and Kitchen Usage

Vendor Disclosure: Renters must identify catering companies on the application.

Kitchen Standards: Tamaya Hall includes a kitchen for staging and warming; it is not for high-grease cooking. All equipment must be cleaned, and the refrigerator emptied and wiped at the conclusion of the event.

Caterer Insurance: Professional caterers must provide proof of insurance, including liquor liability if serving alcohol.

SECTION XII: CONDUCT, DECORATIONS, AND PROHIBITED ITEMS

12.1 Decorating Guidelines

Tabletop Only: Decorations are limited to **tabletops only**. No wall or ceiling decorations are permitted.

Prohibited Attachments: No tape, nails, staples, tacks, or adhesives may be used on walls, woodwork, or ceilings.

Prohibited Items: No confetti, glitter, rice, birdseed, or smoke/fog machines.

Fire Safety: No candles or open flames are permitted.

Table Linens: Linens **must be used** on all tables if food is served to protect the furniture surfaces.

12.2 General Conduct

No Smoking: All indoor facilities are smoke-free; smoking and vaping are prohibited.

Commercial Activity: Facilities may not be used for profit-making, commercial activity, solicitation, or for-profit engagements.

Illegal Activity: Engaging in illegal activity results in immediate arrest and removal.

Animals: Pets are prohibited; only **documented service animals** with proper identification are permitted.

SECTION XIII: PARKING AND ACCESS RESTRICTIONS

13.1 Parking Lot Usage

Capacity: Use is restricted to the parking lot, which has a maximum capacity of **96 vehicles**.

Prohibited Areas: Parking on the Event Lawn or grass is strictly prohibited and subject to towing.

13.2 Limited Access

Non-Exclusive Amenities: The Swimming Pool, Waterslide Area, and Fitness Center are community assets and **cannot be reserved for exclusive use**.

Reserved Access: Access is limited strictly to the area booked. No access is granted to tennis or basketball courts.

Pool Access: The **Pool Cabana** and **Palm Court** are the only rentals that permit guest access to the pool.

SECTION XIV: TAMAYA HALL PREMIUM FACILITY ADDENDUM

Tamaya Hall is the premier asset of the Tamaya community, featuring high-performance hardwood floors and premium custom finishes. Because this space is a "showcase" status, the District maintains an uncompromising standard for its care.

14.1 Absolute Furniture Prohibition

Under no circumstances shall any furniture (tables, chairs, sofas) be dragged, slid, or moved by the Renter, guests, or vendors. Moving furniture risks scratching the floors and will result in **immediate and automatic forfeiture of 100% of the security deposit (\$750.00)**. Custom layouts must be requested 7 days in advance for staff approval and instruction with supervision.

14.2 Rigorous Floor Protection and Decoration Rules

Vendor Equipment: All external equipment (DJ booths, catering carts, photo booths) must have non-marring rubberized feet or be placed on District-approved protective mats/rugs.

Footwear and Spills: Guests are discouraged from wearing stiletto heels (≥ 2.5 in), metal cleats, or spikes. All liquid spills must be blotted immediately.

Restricted Adhesives: No tape, nails, staples, tacks, or screws may be applied to walls, woodwork, or floors. Decorations are limited to **tabletops only**.

Fire Safety: No candles, open flames, smoke machines, or fog machines are permitted.

14.3 Mandatory Photo-Audit Protocol

To ensure transparency and protect the Renter from liability for pre-existing conditions, the following "Photo-Audit" is required:

1. **Pre-Event Photos:** Renter must take **time-stamped photographs** of the entire hall (floors, furniture legs, kitchen, and walls) immediately upon arrival and prior to any setup.
2. **Post-Event Photos:** Renter must take an identical set of photos after cleanup but before departure.
3. **Legal Assumption:** Failure to capture "Before" photos constitutes a binding admission that the facility was in perfect, pristine condition upon arrival.

14.4 Kitchen and Restoration Standards

Tamaya Hall must be returned in "Guest-Ready" condition.

Category	Requirement
Kitchen	Appliances wiped clean; refrigerator emptied/wiped; sink cleared of debris
Trash	All waste bagged and moved to external District dumpster; new liners installed
Surfaces	Tabletops and bar areas wiped free of sticky residue/spills; linens must be used if food is served
Floors	Entire area swept and spot-mopped using only District-approved cleaning agents

14.5 Financial Obligations and Staffing for Tamaya Hall

Fees: Rental is **\$850.00** (6-hour limit) or **\$1,250.00** for a Combo rental (8-hour limit).

Security Deposit: A **\$750.00** performance bond is required at the time of booking.

Mandatory Security: A security officer is required for events with alcohol, >25 guests, or extending past 10:00 p.m.

Alcohol: Requires **\$1,000,000.00** liability insurance naming the District as co-insured and a licensed bartender.

SECTION XV: CLEANUP AND RESTORATION REQUIREMENTS

The facility must be returned in "Guest-Ready" condition to receive a full deposit refund.

Requirement Category	Cleaning Task
Trash Disposal	All trash removed to external District dumpster; liners replaced
Surfaces	All tabletops, counters, and bar areas wiped clean of residue
Kitchen	Refrigerator emptied and wiped; microwave cleaned; sinks cleared
Floors	All floors swept and spot-mopped for spills using approved agents
Furniture	Tables and chairs returned to exact original positions (lifting, not dragging)
Decorations	All tape, balloons, string, and signage removed; no wall damage
Glass/Restrooms	Handprints wiped from glass doors; toilets flushed; debris removed
Personal Property	All catering supplies and personal items removed from premises

SECTION XVI: LEGAL, CANCELLATION, AND INDEMNIFICATION

16.1 Cancellation Policy

Full Refund: Written notice must be communicated at least **two (2) weeks (14 days)** prior to the event.

Late Cancellation: If cancelled less than two weeks prior, the **security deposit is forfeited**, though the rental fee is returned.

No-Show: Reservations are considered cancelled if the Renter is more than **15 minutes late** for the start time, resulting in forfeiture of fees and deposits.

16.2 Indemnification and Liability

The Renter agrees to defend, indemnify, and hold harmless the Beach Community Development District, its supervisors, and staff from all liability, claims, actions, or personal property damage arising from the use of the facilities. Nothing in this Agreement waives the District's sovereign immunity under Section 768.28, Florida Statutes.

SECTION XVII: FACILITY INSPECTION CHECKLIST

This section must be completed by District Staff for office use.

Field	Data
Resident Check-in Time	
Check-out Time	
Floors (Scratches)	Pre-Event: ____ Post-Event: ____ Staff Notes:
Furniture Layout	Pre-Event: ____ Post-Event: ____ Staff Notes:
Kitchen Cleanliness	Pre-Event: ____ Post-Event: ____ Staff Notes:
Trash/Liners	Pre-Event: ____ Post-Event: ____ Staff Notes:
Wall/Paint Condition	Pre-Event: ____ Post-Event: ____ Staff Notes:

Final Disposition of Deposit:

- Full Refund Approved
- Partial Deduction:
Reason _____ (Amt: \$ _____)
- Total Forfeiture:
Reason _____ (Amt: \$ _____)

SECTION XVIII: PRE-EVENT INSPECTION (CHECK-IN)

This section must be completed before any setup or decorations are placed.

Item / Area	Satisfactory? (Y/N)	Pre-Existing Damage / Notes
Floors (Hardwood/Tile/Carpet)		Note any scratches, scuffs, or stains
Furniture (Tables/Chairs/Sofas)		Count present and verify integrity
Walls, Doors, and Baseboards		Note existing marks or adhesive residue
Windows and Glass Doors		Inspect for smudges or fingerprints
Kitchen:		Verify fridge is empty and microwave is

Item / Area	Satisfactory? (Y/N)	Pre-Existing Damage / Notes
Appliances/Countertops		clean
Lighting and HVAC Panels		Confirm functional settings
Trash Receptacles		Ensure all bins are empty with liners

Mandatory Requirement: The Resident is **strongly encouraged** to take **time-stamped photographs** of the facility (floors, furniture legs, and surfaces) upon arrival to establish a baseline.

SECTION XIX: POST-EVENT CLEANUP CHECKLIST (GUEST-READY STANDARDS)

The Renter must satisfy all of the following conditions to be eligible for a full deposit refund.

19.1 General Area Restoration

- **Furniture:** All tables and chairs returned to their **exact original positions**
- **Furniture Movement:** Absolutely no furniture was **dragged or slid** across hardwood floors (Tamaya Hall)
- **Trash Disposal:** All waste bagged, tied, and removed to the **external District dumpster**
- **Liners:** New trash bags/liners installed in all internal receptacles
- **Surfaces:** All tabletops, bar areas, and counters wiped free of sticky residue and debris
- **Decorations:** All tape, strings, balloons, and signs removed; no damage from adhesives

19.2 Kitchen and Appliances

- **Refrigerator:** Completely emptied and interior/exterior wiped down
- **Microwave:** All food residue, grease, and splatters cleaned
- **Sinks and Cabinets:** Sinks cleared and scrubbed; all used cabinets wiped out

19.3 Floors, Glass, and Utilities

- **Floors:** Swept completely and spot-mopped using **District-approved chemicals only**
 - **Glass Doors/Windows:** Handprints and smudges wiped from all glass surfaces
 - **Restrooms:** Toilets flushed and floors cleared of debris
 - **HVAC and Lights:** Lights off and HVAC returned to **76°F / standard unoccupied settings**
-

SECTION XX: FINAL INSPECTION AND DISPOSITION

To be completed by a District Representative after the Renter completes cleanup.

Area	Satisfactory? (Y/N)	Staff Notes / Deduction Charges
Trash and Liners		\$
Floor Condition		\$
Furniture Layout		\$
Kitchen Restoration		\$
Rule Compliance		\$

Deposit Disposition:

- Full Refund Approved
- Partial Deduction:
Reason _____ (Amt: \$ _____)
- Total Forfeiture:
Reason _____ (Amt: \$ _____)

Note: Security deposits are typically processed via check within **10–30 business days** following a satisfactory inspection.

SECTION XXI: ACKNOWLEDGMENT, AUTHORIZATION, AND SIGNATURE

By signing below, the Resident/Member acknowledges and represents as follows:

ACKNOWLEDGMENT OF RECEIPT AND REVIEW: I acknowledge that I have received, read, and fully understand this comprehensive Master Facility Rental Agreement, including all Sections I through XXI contained herein. I have received the full Facility Use Agreement and agree to adhere to all rules, including the **Tamaya Hall Addendum** (if applicable), which strictly prohibits the movement of furniture and requires mandatory photographic documentation to protect the security deposit.

AUTHORIZATION TO BIND ATTENDEES: I represent that I have the full authority to execute this Agreement and to bind all attendees, guests, vendors, contractors, and other persons participating in or attending the event covered by this Agreement to all terms and conditions

contained herein. I accept full responsibility for the conduct of all such persons and for any damage they may cause to the Premises.

ACKNOWLEDGMENT OF STRICT DEPOSIT REQUIREMENTS: I understand that Tamaya Hall contains immaculate hardwood floors and new, premium furniture that require special protection. I acknowledge that the requirements for return of the security deposit are extremely strict. I specifically understand and agree that:

- **NO FURNITURE SHALL BE MOVED, RELOCATED, OR REARRANGED UNDER ANY CIRCUMSTANCES** without the prior written approval of the Facility Manager. Any unauthorized movement of furniture will result in the immediate and automatic forfeiture of 100% of the security deposit (\$750.00).
- I am strongly encouraged to take comprehensive time-stamped photographs of the Premises before and after the event to document the condition and protect myself from liability for pre-existing conditions.
- Failure to take "Before" photographs constitutes a binding admission that the facility was in perfect, pristine condition upon my arrival.
- I accept full financial liability for any damage exceeding the security deposit, including floor refinishing or furniture replacement costs.

COMPLIANCE WITH RULES AND REGULATIONS: I agree to comply with all rules, regulations, policies, and directions from Amenity Facility Staff. I understand that any violation—particularly regarding furniture movement, floor care, unauthorized area access (Pool/Slide), or prohibited items—will result in the total forfeiture of the Security Deposit and potential additional billing.

INDEMNIFICATION AND HOLD HARMLESS: In consideration of being permitted to use the Premises, I hereby agree to defend, indemnify, and hold harmless the Beach Community Development District, its supervisors, agents, employees, and contractors from any and all liability, claims, actions, suits, or demands by any person, corporation, or other entity for any injuries, death, theft, and real or personal property damage of any nature arising out of or in connection with the use of the facilities contemplated by this Agreement.

UNDERSTANDING OF CONSEQUENCES: I understand that failure to comply with the requirements of this Agreement may result in: forfeiture of all or part of the security deposit; additional charges for damage; immediate termination of the event; and loss of future rental privileges.

STEWARDSHIP RESPONSIBILITY: By renting Tamaya Hall or any facility of the Tamaya Amenity Center, I accept a responsibility to serve as a steward of these valuable community assets. I agree to use the facility only for its intended purposes, leave the facility in the same or better condition than it was found, report any damage or maintenance issues to the District, and encourage guests to respect the facility and its rules.

RENTER SIGNATURE AND CERTIFICATION

By signing below, I, the undersigned, hereby certify that I have read and understand this entire Agreement, that all information provided by me is accurate and complete, that I have had the opportunity to ask questions and receive satisfactory answers, and that I agree to be bound by all terms, conditions, and obligations set forth herein.

Resident/Member Signature:	
Printed Name:	
Date:	

DISTRICT REPRESENTATIVE ACKNOWLEDGMENT

District Representative Signature:	
Printed Name/Title:	
Date:	

WITNESS ACKNOWLEDGMENT (OPTIONAL)

Witness Signature:	
Printed Name:	
Date:	

Beach Community Development District 250 International Pkwy. Suite 208, Lake Mary, FL
32746 Phone: 904-329-2277

Document Revision Date: March 2026

EXHIBIT 18



Amenity & Breezeway Security Services Proposal

Prepared by Highline Security

Highline Security
2890 Preveza Court
Jacksonville, FL 32246
Phone: 904-947-0929
Email: info@highlinesecurityservices.com

License No.: B 3300306

Prepared By:
Chris Ziser
Highline Security

Date: March 31, 2026

Introduction

Highline Security provides professional, structured security services tailored to residential communities and amenity environments. Our approach focuses on proactive patrol, visible deterrence, and consistent enforcement of community policies.

This proposal outlines a targeted patrol strategy designed to reduce disturbances, enhance resident safety, and protect community amenities during peak usage hours.

Scope of Services

- Active monitoring of amenity areas and common spaces
- Structured and randomized patrols throughout assigned zones
- Enforcement of CDD rules and community policies
- Response to disturbances, suspicious activity, and violations
- Resident interaction and customer service presence
- Incident documentation and reporting
- Coordination with law enforcement or emergency services when required

Patrol & Monitoring Duties

Areas Covered:

- Amenity center • Pool • Fitness center • Courts • Breezeways

Patrol Method:

Officers will conduct continuous patrol cycles, averaging one full property sweep every 20–30 minutes, ensuring consistent visibility and rapid response capability.

Strategic Coverage Schedule

Mon–Thu: 6PM–10PM

Friday: 6PM–12AM

Saturday: 10AM–12AM

Sunday: 10AM–10PM

This schedule is designed to align coverage with peak usage periods, when amenities experience the highest traffic and increased likelihood of disturbances.

Pricing Structure

Service Rate: \$25.00 per hour

Includes patrol services, monitoring, enforcement, incident response, and reporting.

Incident Response Calls

Additional Service Calls:

\$25.00 per call (includes first hour).

Additional time billed at \$25.00 per hour.

Weekly Coverage Cost

Total Weekly Coverage: 48

Total Weekly Cost: \$1,200

Day	Hours	Cost
Mon–Thu	16	\$400
Friday	6	\$150
Saturday	14	\$350
Sunday	12	\$300
Total Weekly Hours	48	
Total Weekly Cost		\$1,200

Cost Per Household

944 homes

Annual: \$66.10 per home

Monthly: \$5.51 per home

Approx. cost of a cup of coffee per month per household.

Liability Reduction for the CDD

A consistent security presence significantly reduces liability exposure by proactively addressing unsafe conditions, enforcing community policies, documenting incidents, and initiating timely response to emergencies.

Amenity Protection & Resident Safety

Helps prevent unauthorized guests, vandalism, disturbances, and conflicts while maintaining a safe environment.

Reporting & Accountability

All activity is documented through a digital reporting system, including Daily Activity Reports and Incident Reports. Reports are time-stamped, trackable, and available to management upon request. This ensures full transparency, accountability, and performance verification.

Why Highline Security

- Professionally trained and uniformed officers
- Structured patrol methodology with accountability
- Clear and consistent reporting systems
- Responsive communication with management
- Experience serving residential communities in Jacksonville
- Licensed and compliant with Florida security regulations

Holiday Coverage

Holiday coverage billed at 1.5x standard rate (\$37.50/hour) on recognized federal holidays.

Terms & Billing

- Billing: Monthly invoicing
- Payment Terms: Net 14 (or whatever you want—recommend Net 14 or Net 30)
- Services are preventative in nature and not a guarantee of safety
- Schedule adjustments may be made based on community needs
- Additional services outside scope billed separately.

Acceptance

Upon approval, Highline Security will coordinate implementation and deployment within 1–3 weeks of authorization.

EXHIBIT 19



1128 Carmona Place, St. Augustine, FL 32092
 Telephone: (904) 315-3933; (904) 315-3944

Quote: 3010
 Date: 04/06/26
 Quote Expires: 04/21/26

PROJECT:
Opt. 1 Chaise Lounges

BILLING ADDRESS:
 Beach CDD
 250 International Parkway, Suite 208
 Lake Mary, FL 32746

SHIPPING ADDRESS:
 Tamaya Clubhouse
 12788 Meritage Boulevard, Jacksonville, FL 32246

PAYMENT TERMS: 100% PAYMENT DUE AT TIME OF ORDER

DESCRIPTION	STYLE	SIZE	FABRIC / FRAME	UNIT \$	QTY.	TOTAL \$
Chaise Lounge, Armless, Sling, 14" Seat Height, Stackable	Sling	14" Seat	TBD / TBD	\$426.00	60	\$25,560.00
Discount				-\$21.30	60	-\$1,278.00

Freight Includes: Yes/No	<i>Estimated Lead Time: 10 - 12 Weeks.</i> <i>Payment is Required at Time of Order.</i> <i>Lead Time begins once payment has been recieved.</i> Southern Breeze will meet truck for delivery, offload, unwrap, and set up all items on pool deck.	Product Total	\$24,282.00
Call Prior to Delivery: Y		Freight	\$1,000.00
Lift Gate: N		TAX EXEMPT	\$0.00
Limited Access Delivery: N		TOTAL	\$25,282.00

TERMS & CONDITIONS: All sales are final and can not be cancelled, returned, or refunded. A resale tax certificate or tax exemption certificate must be supplied at time of order. If not received, sales tax will be applied. All orders are custom made to order & require 100% Payment Due at Time of Order. Checks should be made payable to Southern Breeze Outdoor Furnishings, LLC. All orders will be drop shipped to customer unless specified otherwise. Additional freight and/or handling charges may be applied, and not limited to, receipt services; residential, church, or school deliveries; lift gates; change in delivery address and/or rescheduling changes of delivery date, time, or location.

I agree to order specifications above, quantities, pricing, terms & conditions: _____ Southern Breeze Outdoor Furnishings, LLC
 _____ / _____
 Purchaser's Signature / Printed Name Date Chris Smith - VP - Business Development
Chris Smith

By signing below, I acknowledge that lead times and production do not begin until payment has been received.

 Purchaser's Signature / Printed Name Date

Design Option - 1

1" Round Aluminum Frame, Sling Fabric

St. Augustine, Florida * www.southernbreezeof.com * (904) 315-3944

Proudly Made in the USA, Commercial Warranty - 10 Year Frame, 1 Year Sling; 3 Year Powdercoat

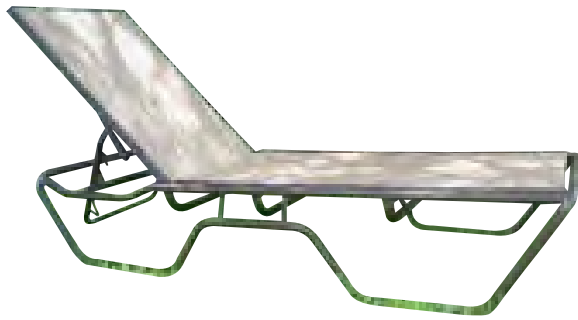

Armless Sun Lounger
Stackable -

24"W x 79"D x 12"H; 25 lbs.
 Standard Seat Height: 12"
 Seat Height Available in:
 14", 16", 19", and 24"



Stackable



Sun Lounger with Arms
Stackable -

24"W x 79"D x 12"H; 25 lbs.
 Standard Seat Height: 12"
 Seat Height Available in:
 14", 16", 19", and 24"



Dining Chair with Arms
Stackable -

22"W x 18"D x 35"H; 10 lbs.
 Seat Height: 17"



Recliner with Arms - \$319.00



*ADA & Senior Friendly Chaise Lounges Available.

Recliner with Arms, Adjustable, Stackable

1" Round Aluminum Frame, Sling Fabric

St. Augustine, Florida * www.southernbreezeof.com * (904) 315-3944 or (904) 315-3933

Proudly Made in the USA, Commercial Warranty - 10 Year Frame, 1 Year Sling; 3 Year Powdercoat

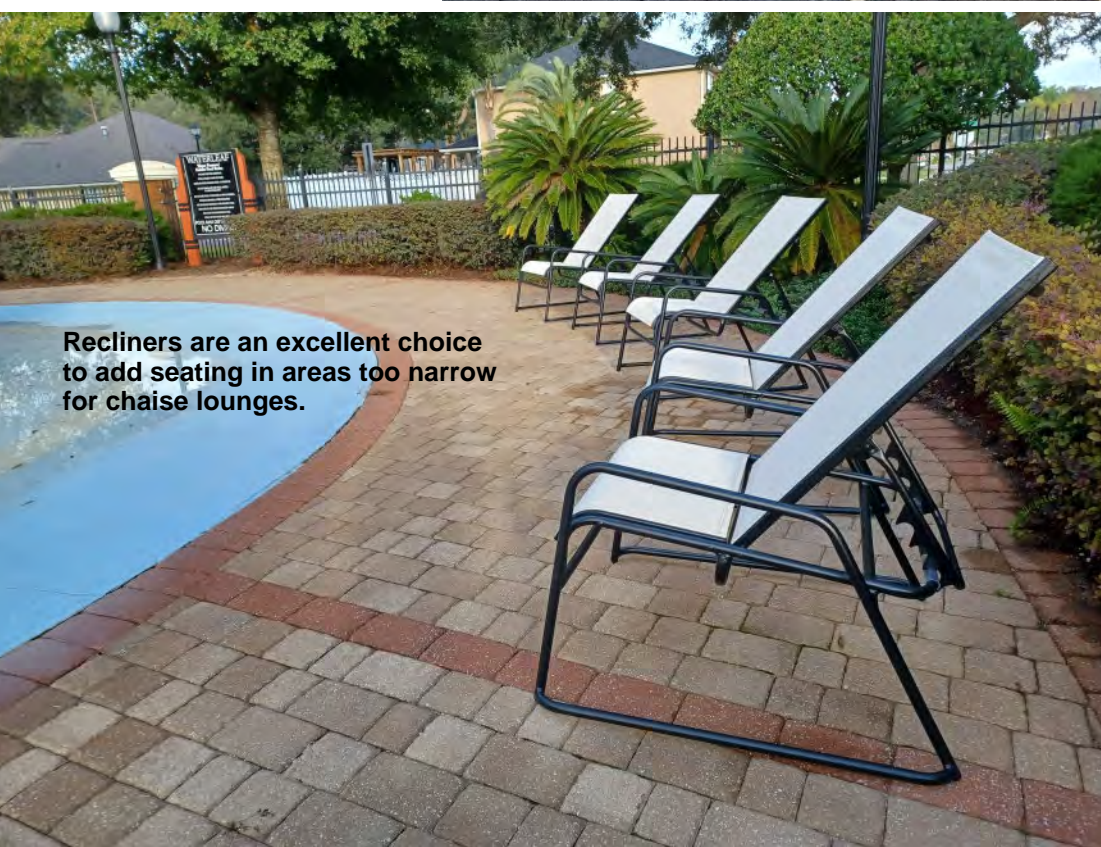

Design Option 1

1" Round Aluminum Frame, Sling Fabric

St. Augustine, Florida * www.southernbreezeof.com * (904) 315-3944



Standard Frame Colors

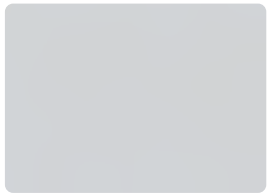

Anodized Silver



White



Vanilla



Yellow



Citron Yellow



Royal Blue



Navy Blue



Grey

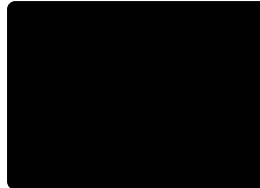

Gloss Black

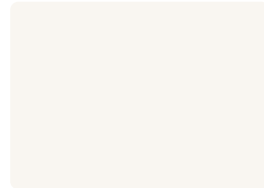

Off White



Putty



Coffee



Mistletoe

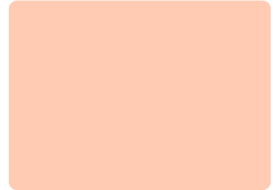

Papaya



Holly Green



Driftwood



Camel



Dark Green



French Blue



Clover



Lesure Brown



Adobe



Burgandy



Sherwood Green



Deepwater Blue



Forest Green

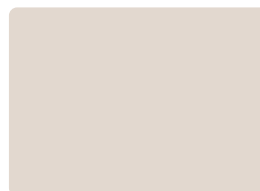

Dove

Frame & Faux Teak Color Selection

St. Augustine, Florida * www.southernbreezeof.com * (904) 315-3944

Standard Textured Frame Colors - No Additional Fee



Bronze



Luna



Sand



Graphite



Sandstone



Speckled Oak

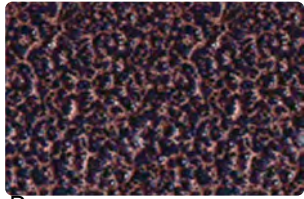

Penny

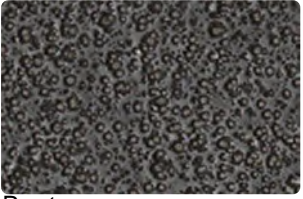

Pewter



Weather Vein

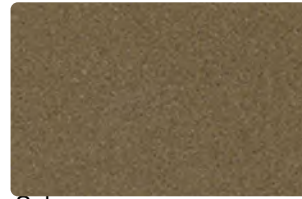

Sahara



Textured Black

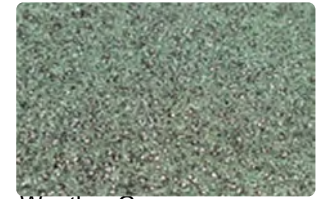

Weather Green

Faux Teak Color Choices

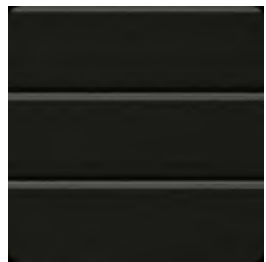

Black

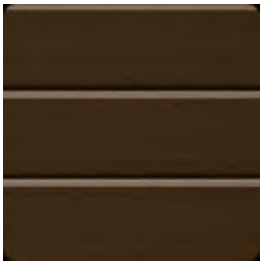

Brown



Cedar

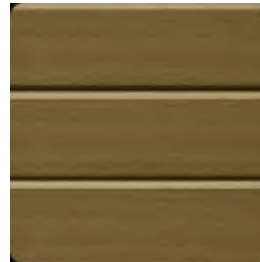

Driftwood



Gray



White

Standard Sling Colors



Azure



Motley Weave

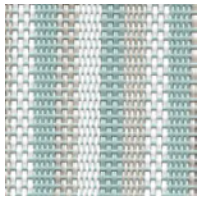

Aquafino

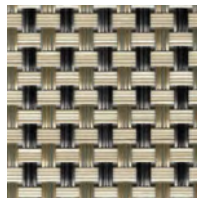

Balsa

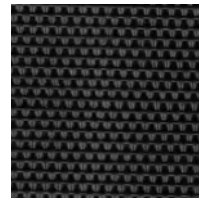

Black Plus



Blue Lagoon

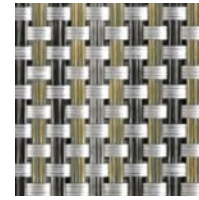

Cane Wicker
Aluminum



Chesterfield



Orange Envy

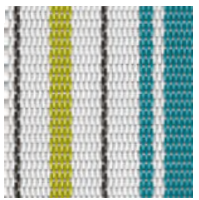

Coast Line
Peacock



Cordoba



Delray Stripe
Poolside

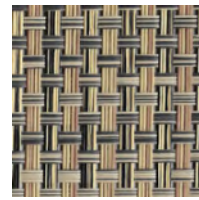

Desert

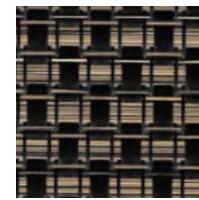

Driftwood

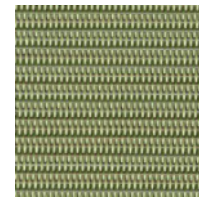

Dupione Kiwi

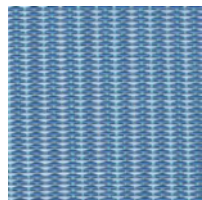

Dupioni Poolside

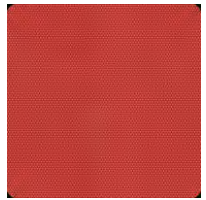

Salsa Shade

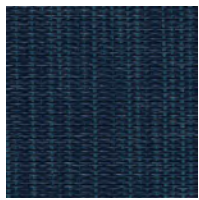

Dupione Sapphire

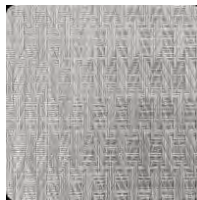

Silver Lining



Teal Crush



Durango

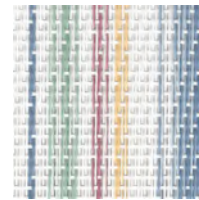

Elizabeth

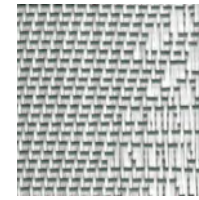

Fern Dance

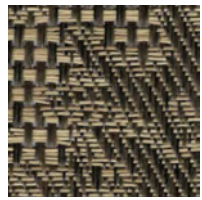

Forest Abby



Green Lake

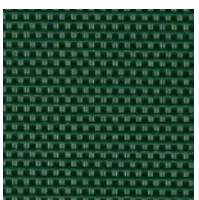

Forest Green Plus

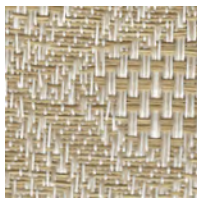

Forest Pebble

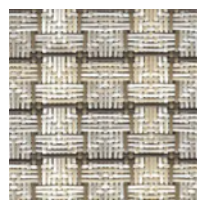

Fresco

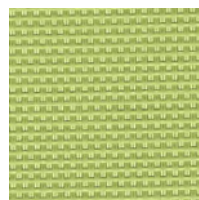

Green Garden Plus



Huffman

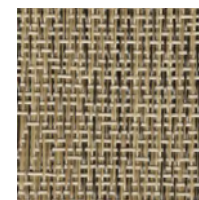

Island Palms Sadat

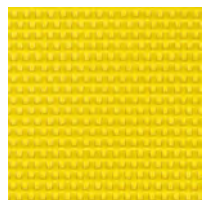

Lemon Yellow

Standard Sling Colors continued

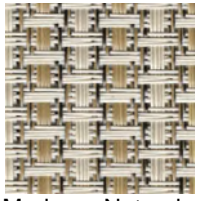

Moderna Natural



Montego

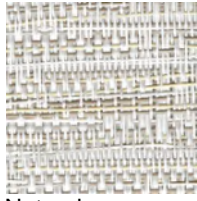

Natural



Navy Plus

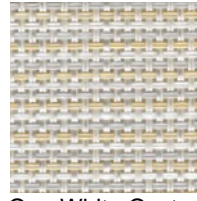

Oga White Oyster

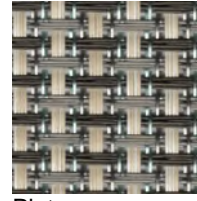

Plata



Lime Light

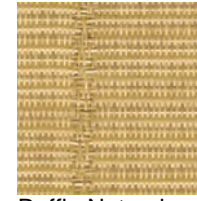

Raffia Natural



Raw Linen

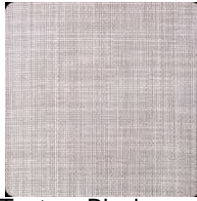

Texture Blush

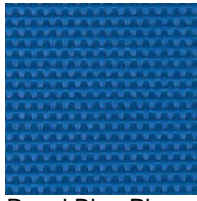

Royal Blue Plus

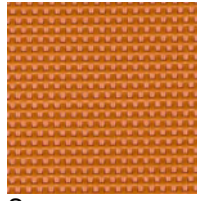

Snappy

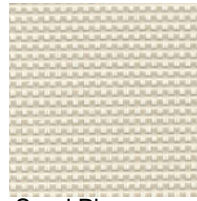

Sand Plus



Santiago Stripe

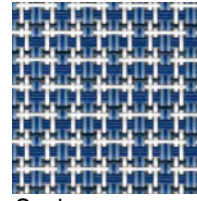

Seabreeze



White Plus



Sierra Sands



Spa Stripe

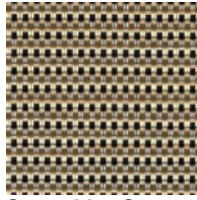

Straw Mat Cognac

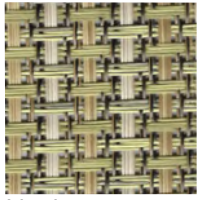

Verde

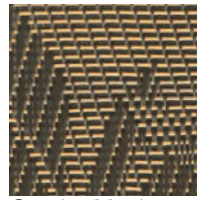

Sumba Mocha

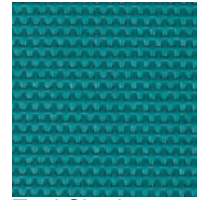

Teal Shade



Tempo Stone Stripe



Tropical Foliage

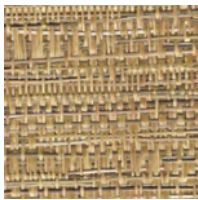

Tropico

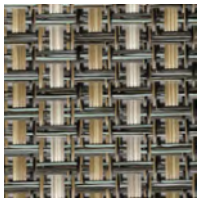

Turquesa

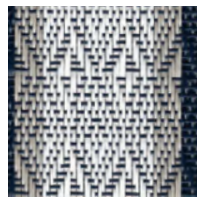

Valencia Blue



Verdanda Nutmeg

EXHIBIT 20



1128 Carmona Place, St. Augustine, FL 32092
 Telephone: (904) 315-3933; (904) 315-3944

Quote: 3011
 Date: 04/06/26
 Quote Expires: 04/21/26

PROJECT:
Opt. 2 Chaise Lounges

BILLING ADDRESS:
 Beach CDD
 250 International Parkway, Suite 208
 Lake Mary, FL 32746

SHIPPING ADDRESS:
 Tamaya Clubhouse
 12788 Meritage Boulevard, Jacksonville, FL 32246

PAYMENT TERMS: 100% PAYMENT DUE AT TIME OF ORDER

DESCRIPTION	STYLE	SIZE	FABRIC / FRAME	UNIT \$	QTY.	TOTAL \$
Chaise Lounge, Armless, Sling, 14" Seat Height, Stackable	Sling	14" Seat	TBD / TBD	\$511.00	60	\$30,660.00
Discount				-\$25.55	60	-\$1,533.00

Freight Includes: Yes/No	<i>Estimated Lead Time: 10 - 12 Weeks.</i> <i>Payment is Required at Time of Order.</i> <i>Lead Time begins once payment has been recieved.</i> Southern Breeze will meet truck for delivery, offload, unwrap, and set up all items on pool deck.	Product Total	\$29,127.00
Call Prior to Delivery: Y		Freight	\$1,000.00
Lift Gate: N		TAX EXEMPT	\$0.00
Limited Access Delivery: N		TOTAL	\$30,127.00

TERMS & CONDITIONS: All sales are final and can not be cancelled, returned, or refunded. **A resale tax certificate or tax exemption certificate must be supplied at time of order.** If not received, sales tax will be applied. All orders are custom made to order & require 100% Payment Due at Time of Order. Checks should be made payable to Southern Breeze Outdoor Furnishings, LLC. All orders will be drop shipped to customer unless specified otherwise. **Additional freight and/or handling charges** may be applied, and not limited to, receipt services; residential, church, or school deliveries; lift gates; change in delivery address and/or rescheduling changes of delivery date, time, or location.

I agree to order specifications above, quantities, pricing, terms & conditions: Southern Breeze Outdoor Furnishings, LLC

/

Purchaser's Signature / Printed Name Chris Smith
 Date Chris Smith - VP - Business Development

By signing below, I acknowledge that lead times and production do not begin until payment has been received.

Purchaser's Signature / Printed Name Date

Design Option - 2

1-1/2" x 3/4" Flat Aluminum Frame, Sling Fabric

St. Augustine, Florida * www.southernbreezeof.com * (904) 315-3944 or (904) 315-3933

*ADA & Senior Friendly Chaise Lounges Available.

Proudly Made in the USA, Commercial Warranty - 10 Year Frame, 1 Year Sling; 3 Year Powdercoat



Armless Sun Lounger - Stackable
Seat Height: 14"



Sun Lounger with Arms - Stackable
Seat Height: 16"



Dining Arm Chair - Stackable
Seat Height: 16"



Recliner with Arms
Seat Height: 16"
\$441.00



Barstool with Arms
Seat Height: 30"



Armless Bar Stool
Seat Height: 29"



Recliners

1-1/2" x 3/4" Flat Aluminum Frame, Sling Fabric

St. Augustine, Florida * www.southernbreezef.com * (904) 315-3944 or (904) 315-3933

Proudly Made in the USA, Commercial Warranty - 10 Year Frame, 1 Year Sling; 3 Year Powdercoat



Design Option 2

1-1/2" x 3/4" Flat Aluminum Frame, Sling Fabric

St. Augustine, Florida * www.southernbreezeof.com * (904) 315-3944 or (904) 315-3933

Proudly Made in the USA, Commercial Warranty - 10 Year Frame, 1 Year Sling; 3 Year Powdercoat



Frame Color Selection

St. Augustine, Florida * www.southernbreezeof.com * (904) 315-3944

Standard Frame Colors

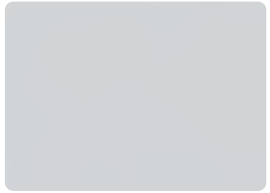

Anodized Silver



White



Vanilla



Yellow



Citron Yellow



Royal Blue



Navy Blue



Grey



Gloss Black

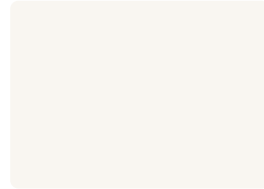

Off White



Putty



Coffee



Mistletoe



Papaya



Holly Green



Driftwood



Camel



Dark Green



French Blue



Clover



Lesure Brown



Adobe



Burgandy



Sherwood Green



Deepwater Blue



Forest Green

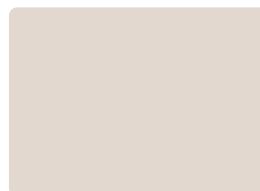

Dove

Frame & Poly Lumber Color Selection

St. Augustine, Florida * www.southernbreezef.com * (904) 315-3944

Standard Textured Frame Colors - No Additional Fee



Bronze



Luna



Sand



Graphite



Sandstone



Speckled Oak

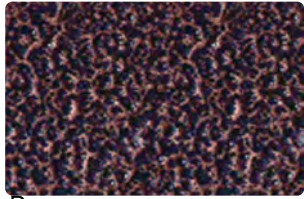

Penny

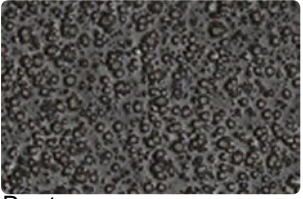

Pewter



Weather Vein

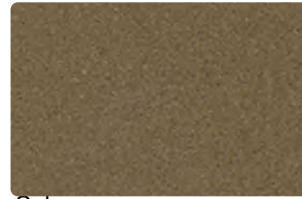

Sahara



Textured Black

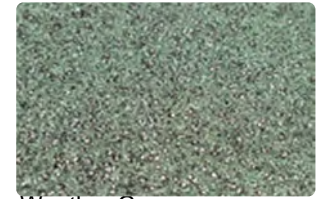

Weather Green

Plastic Lumber Color Choices

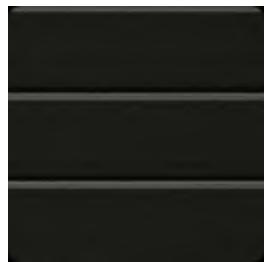

Black

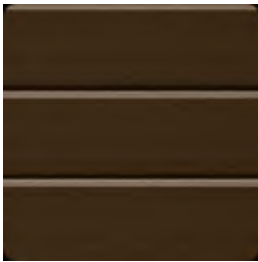

Brown



Cedar

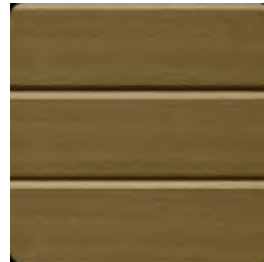

Driftwood



Gray



White

Standard Sling Colors

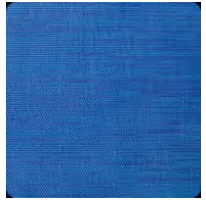

Azure



Motley Weave

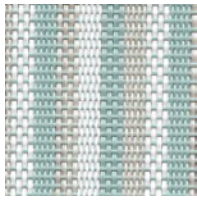

Aquafino

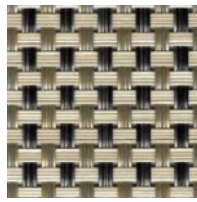

Balsa

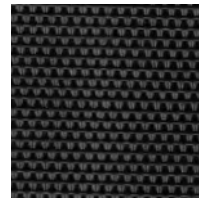

Black Plus

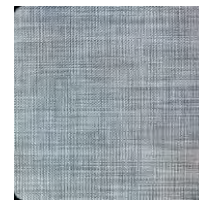

Blue Lagoon

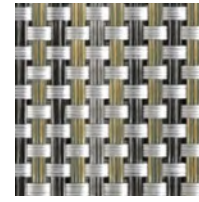

Cane Wicker
Aluminum



Chesterfield



Orange Envy

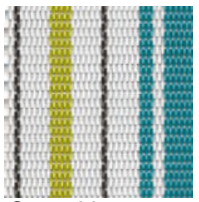

Coast Line
Peacock



Cordoba



Delray Stripe
Poolside

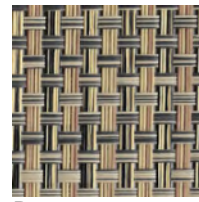

Desert



Driftwood

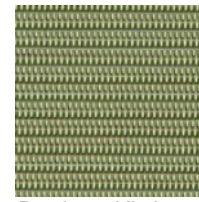

Dupione Kiwi

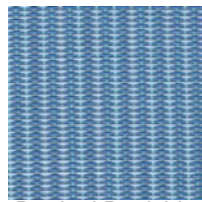

Dupioni Poolside

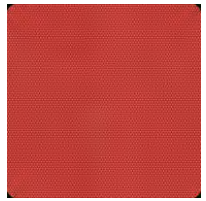

Salsa Shade

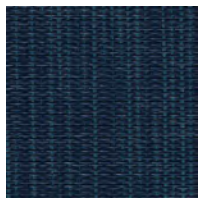

Dupione Sapphire

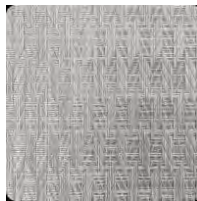

Silver Lining



Teal Crush



Durango



Elizabeth

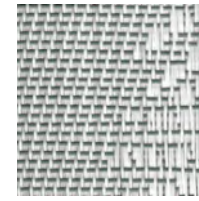

Fern Dance

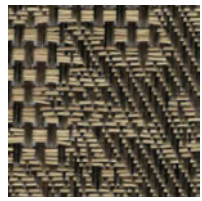

Forest Abby



Green Lake

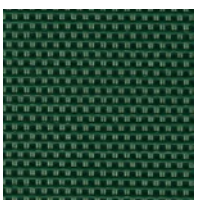

Forest Green Plus

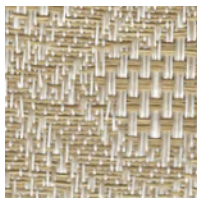

Forest Pebble

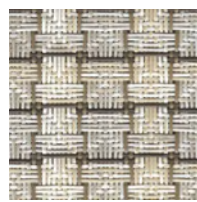

Fresco

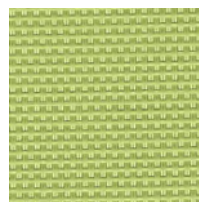

Green Garden Plus



Huffman

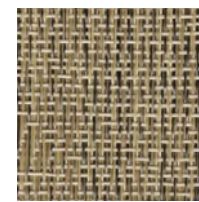

Island Palms Sadat

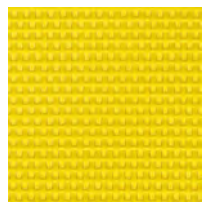

Lemon Yellow

Standard Sling Colors continued

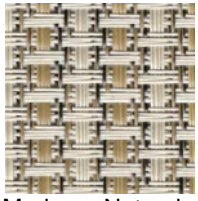

Moderna Natural



Montego

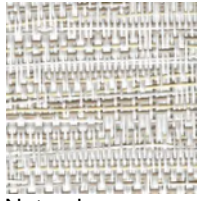

Natural



Navy Plus

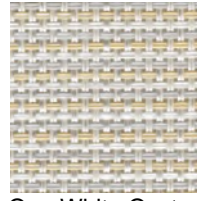

Oga White Oyster

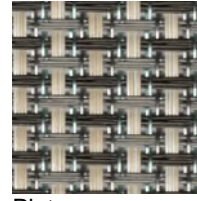

Plata



Lime Light

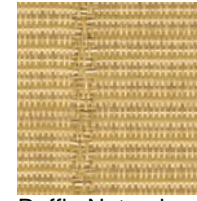

Raffia Natural



Raw Linen

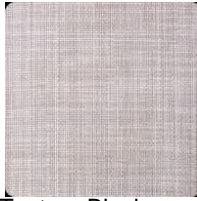

Texture Blush

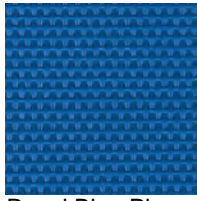

Royal Blue Plus

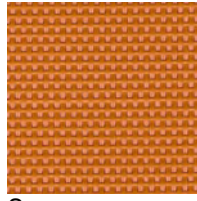

Snappy

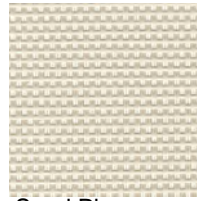

Sand Plus

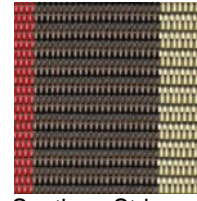

Santiago Stripe

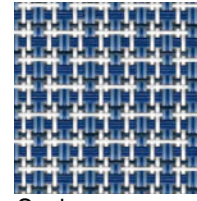

Seabreeze

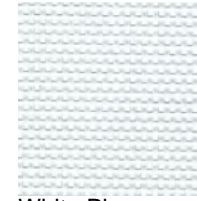

White Plus

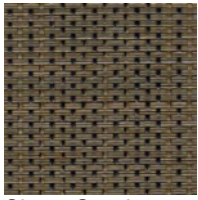

Sierra Sands



Spa Stripe

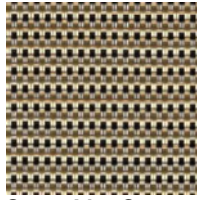

Straw Mat Cognac

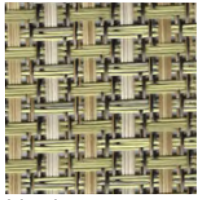

Verde

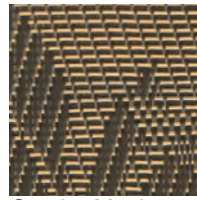

Sumba Mocha

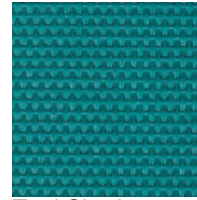

Teal Shade



Tempo Stone Stripe



Tropical Foliage

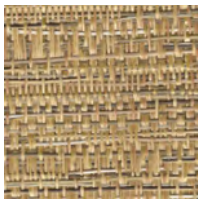

Tropico

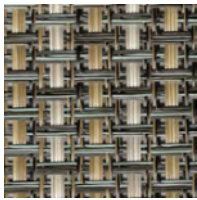

Turquesa



Valencia Blue



Verdanda Nutmeg

EXHIBIT 21



1128 Carmona Place, St. Augustine, FL 32092
 Telephone: (904) 315-3933; (904) 315-3944

Quote: 3012
 Date: 04/06/26
 Quote Expires: 04/21/26

PROJECT:
Opt. 3 Chaise Lounges

BILLING ADDRESS:
 Beach CDD
 250 International Parkway, Suite 208
 Lake Mary, FL 32746

SHIPPING ADDRESS:
 Tamaya Clubhouse
 12788 Meritage Boulevard, Jacksonville, FL 32246

PAYMENT TERMS: 100% PAYMENT DUE AT TIME OF ORDER

DESCRIPTION	STYLE	SIZE	FABRIC / FRAME	UNIT \$	QTY.	TOTAL \$
Chaise Lounge, Armless, Sling, 14" Seat Height, Stackable	Sling	14" Seat	TBD / TBD	\$636.00	60	\$38,160.00
Discount				-\$31.80	60	-\$1,908.00

Freight Includes: Yes/No	<i>Estimated Lead Time: 10 - 12 Weeks. Payment is Required at Time of Order. Lead Time begins once payment has been recieved. Southern Breeze will meet truck for delivery, offload, unwrap, and set up all items on pool deck.</i>	Product Total	\$36,252.00
Call Prior to Delivery: Y		Freight	\$1,000.00
Lift Gate: N		TAX EXEMPT	\$0.00
Limited Access Delivery: N		TOTAL	\$37,252.00

TERMS & CONDITIONS: All sales are final and can not be cancelled, returned, or refunded. A resale tax certificate or tax exemption certificate must be supplied at time of order. If not received, sales tax will be applied. All orders are custom made to order & require 100% Payment Due at Time of Order. Checks should be made payable to Southern Breeze Outdoor Furnishings, LLC. All orders will be drop shipped to customer unless specified otherwise. Additional freight and/or handling charges may be applied, and not limited to, receipt services; residential, church, or school deliveries; lift gates; change in delivery address and/or rescheduling changes of delivery date, time, or location.

I agree to order specifications above, quantities, pricing, terms & conditions: _____ Southern Breeze Outdoor Furnishings, LLC

 Purchaser's Signature / Printed Name Date Chris Smith - VP - Business Development
Chris Smith

By signing below, I acknowledge that lead times and production do not begin until payment has been received.

 Purchaser's Signature / Printed Name Date

Design Option - 3

Chairs - 1-1/2" x 3/4" Flat Aluminum Frame, Sling Fabric
 Chaise - 1" x 2" Aluminum Frame, Sling Fabric

St. Augustine, Florida * www.southernbreezeof.com * (904) 315-3944

Proudly Made in the USA, Warranty - 10 Year Frame, 1 Year Sling; 3 Year Powdercoat



Sun Lounger, Armless, Stackable

Sun Lounger, Seat Height: 14", Dining Chair, Seat Height: 16", Recliner, Seat Height: 14"



Dining Arm Chair Stackable



Armless Dining Chair, Stackable



Barstool with Arms



\$486.00 (no arms)
 \$536.00 (with arms)

Armless Recliner

ADA (19" seat height) and Senior Friendly (24" seat height) Sun Loungers are available.



Recliners

Chairs - 1-1/2" x 3/4" Flat Aluminum Frame, Sling Fabric

St. Augustine, Florida * www.southernbreezeof.com * (904) 315-3944 or (904) 315-3933

Proudly Made in the USA, Commercial Warranty - 10 Year Frame, 1 Year Sling; 3 Year Powdercoat

Recliners are an excellent choice to add seating in areas too narrow for chaise lounges.



Design Option 3

St. Augustine, Florida * www.southernbreezeof.com * (904) 315-3944 or (904) 315-3933

Proudly Made in the USA, Commercial Warranty - 10 Year Frame, 1 Year Slings; 3 Year Powdercoat



Standard Frame Colors

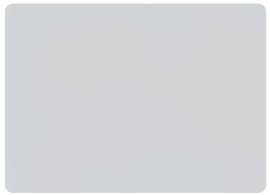

Anodized Silver



White



Vanilla



Yellow



Citron Yellow



Royal Blue



Navy Blue



Grey



Gloss Black

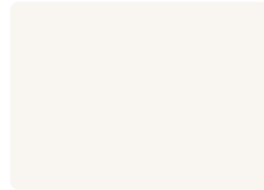

Off White



Putty



Coffee



Mistletoe



Papaya



Holly Green



Driftwood



Camel



Dark Green



French Blue



Clover



Lesure Brown



Adobe



Burgandy



Sherwood Green



Deepwater Blue



Forest Green



Dove

Frame & Faux Teak Color Selection

St. Augustine, Florida * www.southernbreezeof.com * (904) 315-3944

Standard Textured Frame Colors - No Additional Fee



Bronze



Luna



Sand



Graphite



Sandstone



Speckled Oak

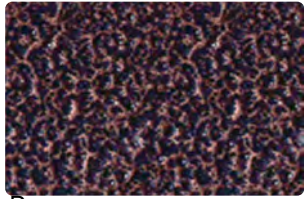

Penny

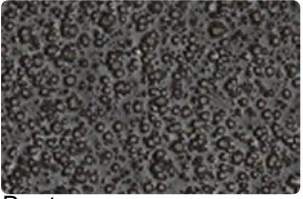

Pewter



Weather Vein

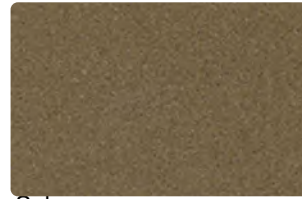

Sahara



Textured Black

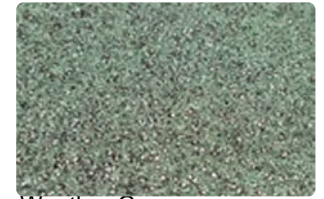

Weather Green

Faux Teak Color Choices

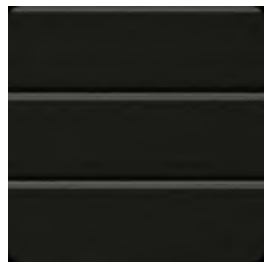

Black

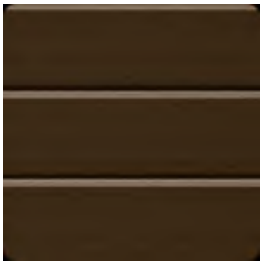

Brown



Cedar

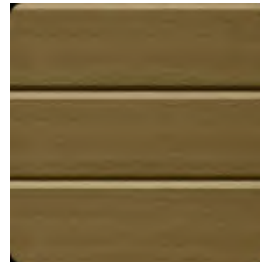

Driftwood



Gray



White

Standard Sling Colors



Azure



Motley Weave

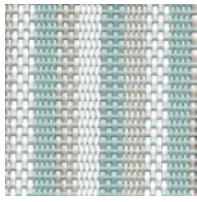

Aquafino

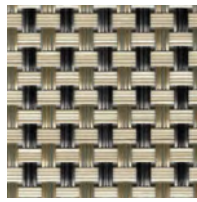

Balsa

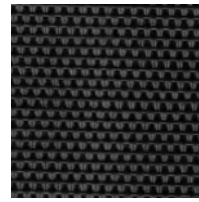

Black Plus

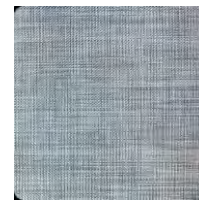

Blue Lagoon

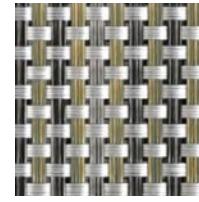

Cane Wicker
Aluminum



Chesterfield



Orange Envy

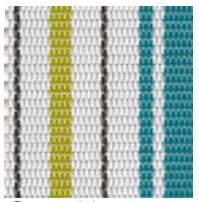

Coast Line
Peacock



Cordoba



Delray Stripe
Poolside

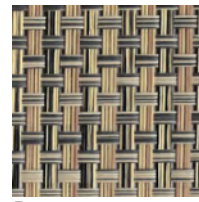

Desert



Driftwood

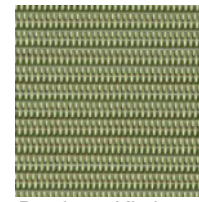

Dupione Kiwi

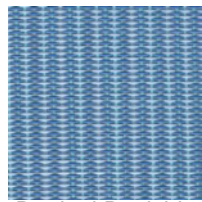

Dupioni Poolside

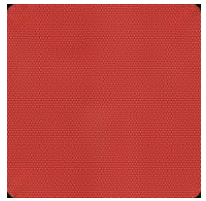

Salsa Shade

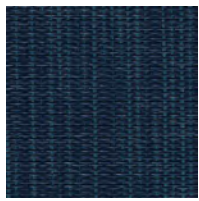

Dupione Sapphire

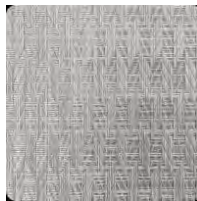

Silver Lining



Teal Crush



Durango



Elizabeth

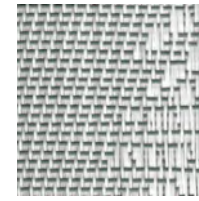

Fern Dance

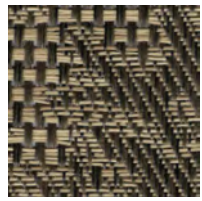

Forest Abby



Green Lake



Forest Green Plus

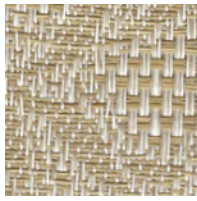

Forest Pebble



Fresco

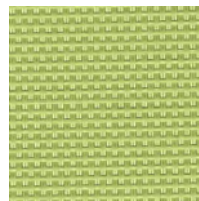

Green Garden Plus



Huffman



Island Palms Sadat

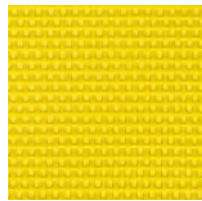

Lemon Yellow

Standard Sling Colors continued

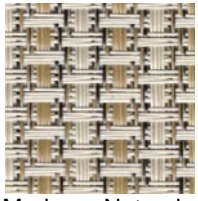

Moderna Natural



Montego

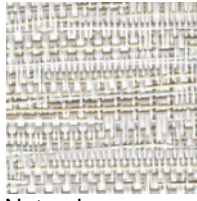

Natural



Navy Plus

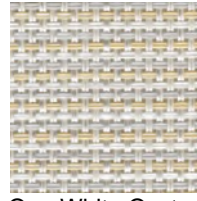

Oga White Oyster

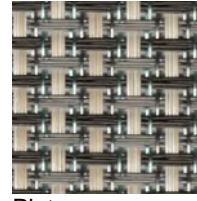

Plata



Lime Light

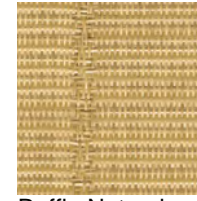

Raffia Natural



Raw Linen

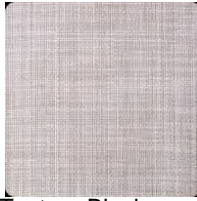

Texture Blush

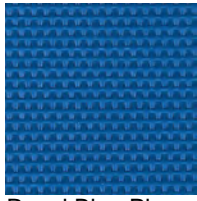

Royal Blue Plus

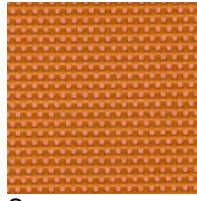

Snappy

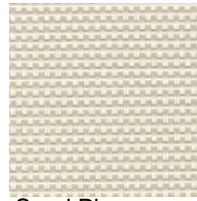

Sand Plus

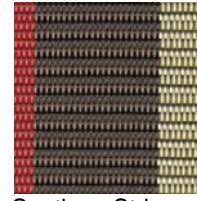

Santiago Stripe

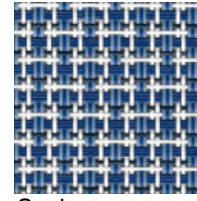

Seabreeze

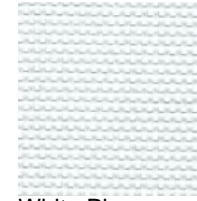

White Plus

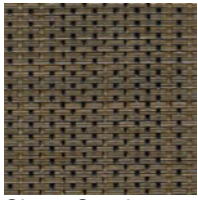

Sierra Sands



Spa Stripe

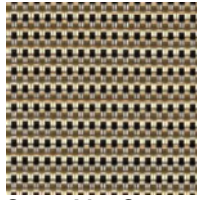

Straw Mat Cognac

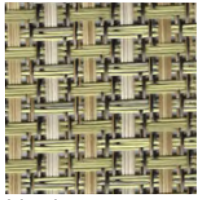

Verde

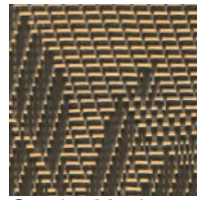

Sumba Mocha

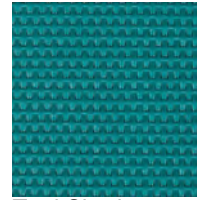

Teal Shade



Tempo Stone Stripe



Tropical Foliage

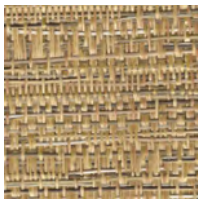

Tropico

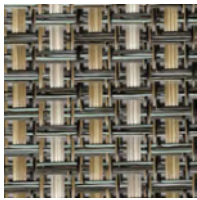

Turquesa



Valencia Blue



Verdanda Nutmeg

EXHIBIT 22

RESOLUTION 2026-05

A RESOLUTION OF THE BOARD OF SUPERVISORS OF THE BEACH COMMUNITY DEVELOPMENT DISTRICT RATIFYING THE CLASSIFICATION OF SURPLUS TANGIBLE PERSONAL PROPERTY; RATIFYING THE DISPOSITION OF SURPLUS TANGIBLE PERSONAL PROPERTY; PROVIDING A SEVERABILITY CLAUSE; AND PROVIDING AN EFFECTIVE DATE.

WHEREAS, the Beach Community Development District ("**District**") is a local unit of special-purpose government established pursuant to Chapter 190, *Florida Statutes*, for the purpose of providing, operating and maintaining infrastructure improvements, facilities and services to the lands within the District; and

WHEREAS, as such, the District is a governmental unit within the meaning of Chapter 274, *Florida Statutes* ("**Governmental Unit**"); and

WHEREAS, the District has purchased and owns certain tangible personal property described as sixteen (16) chairs and one (1) ottoman ("**Surplus Property**"); and

WHEREAS, the District desires to ratify its actions in classifying the Surplus Property as surplus tangible personal property, and to determine that the continued use of the Surplus Property is uneconomical, inefficient to maintain, and/or serves no useful function; and

WHEREAS, the Board of Supervisors of the District ("**Board**") previously considered the best interests of the District, the value and condition of the Surplus Property, and the probability of the Surplus Property being desired by prospective donor recipients or purchasers; and

WHEREAS, the District desires to ratify its actions in coordinating the disposition of the Surplus Property for value to any person, or for value without bids to the state, to any Governmental Unit, or to any political subdivision as defined in section 1.01, *Florida Statutes*, or for value to another governmental unit or to a private nonprofit agency as defined in section 273.01 and 274.01, *Florida Statutes*; or, if such sale cannot reasonably be accomplished, by donating it either to another Governmental Unit or to a private nonprofit agency as defined in section 273.01 and 274.01, *Florida Statutes*; or, if neither sale nor donation can reasonably be accomplished, the District hereby determines that the Surplus Property is without commercial value and desires to destroy or abandon it, all in accordance with the provisions of Chapter 274, *Florida Statutes*; and

WHEREAS, the District believes that disposing of the Surplus Property in this fashion is the most efficient and cost-effective means of disposing of the Surplus Property; and

WHEREAS, based on evaluation by staff of the condition of each piece of Surplus Property and the costs associated with disassembly, removal, and haul-off, the District has estimated the

value of each class of the Surplus Property to be less than Five Thousand Dollars (\$5,000); and

WHEREAS, the District believes that it is in its best interests to ratify the disposition of the Surplus Property in this fashion.

NOW, THEREFORE, BE IT RESOLVED BY THE BOARD OF SUPERVISORS OF THE BEACH COMMUNITY DEVELOPMENT DISTRICT:

SECTION 1. INCORPORATION OF RECITALS. All of the representations, findings and determinations contained within the recitals stated above are recognized as true and accurate and are expressly incorporated into this Resolution.

SECTION 2. CLASSIFICATION OF SURPLUS TANGIBLE PERSONAL PROPERTY. The District hereby ratifies the classification of the Surplus Property as surplus tangible personal property, and the determination that the Surplus Property is obsolete, and/or continued use of the Surplus Property is uneconomical, inefficient to maintain, and/or serves no useful function.

SECTION 3. DISPOSITION OF SURPLUS TANGIBLE PERSONAL PROPERTY. The District hereby ratifies the actions of District staff in disposing of the Surplus Property for value to any person, or for value without bids to the state, to any Governmental Unit, or to any political subdivision as defined in section 1.01, *Florida Statutes*, or for value to another Governmental Unit or to a private nonprofit agency as defined in section 273.01 and 274.01, *Florida Statutes*; or, if such sale cannot reasonably be accomplished, by donating it either to another Governmental Unit or to a private nonprofit agency as defined in section 273.01 and 274.01 *Florida Statutes*; or, if neither sale nor donation can reasonably be accomplished, by destroying or abandoning it, all in accordance with the provisions of Chapter 274, *Florida Statutes*.

SECTION 4. SEVERABILITY. The invalidity or unenforceability of any one or more provisions of this Resolution shall not affect the validity or enforceability of the remaining portions of this Resolution, or any part thereof.

SECTION 5. EFFECTIVE DATE. This Resolution shall take effect immediately upon its passage and adoption.

PASSED AND ADOPTED this 20th day of April 2026.

ATTEST:

BEACH COMMUNITY DEVELOPMENT DISTRICT

Secretary/Assistant Secretary

Chairperson, Board of Supervisors

EXHIBIT 23

RESOLUTION 2026-06

A RESOLUTION OF THE BOARD OF SUPERVISORS OF THE BEACH COMMUNITY DEVELOPMENT DISTRICT TO DESIGNATE DATE, TIME AND PLACE OF PUBLIC HEARING AND AUTHORIZATION TO PUBLISH NOTICE OF SUCH HEARING FOR THE PURPOSE OF ADOPTING RULES OF PROCEDURE; AND PROVIDING AN EFFECTIVE DATE

WHEREAS, the Beach Community Development District (the “District”) is a local unit of special-purpose government created and existing pursuant to Chapter 190, *Florida Statutes*; and

WHEREAS, the Board of Supervisors of the District (the “Board”) is authorized by Section 190.011(5), *Florida Statutes*, to adopt rules and orders pursuant to Chapter 120, *Florida Statutes*.

NOW, THEREFORE, BE IT RESOLVED BY THE BOARD OF SUPERVISORS OF THE BEACH COMMUNITY DEVELOPMENT DISTRICT:

SECTION 1. A Public Hearing will be held to adopt Rules of Procedure on Monday, July 20, 2026, at 6:00 p.m., at 12788 Meritage Blvd. Jacksonville, FL 32246.

SECTION 2. The District Secretary is directed to publish notice of the hearing in accordance with Section 120.54, *Florida Statutes*.

SECTION 3. This Resolution shall become effective immediately upon its adoption.

PASSED AND ADOPTED this 20th day of April, 2026.

ATTEST:

BEACH COMMUNITY DEVELOPMENT DISTRICT

Secretary/Assistant Secretary

Chair/Vice Chair, Board of Supervisors